



# Biology

Student Textbook  
Grade 12

Author: Steve Potter

Adviser: Alemu Asfaw

Evaluators: Solomon Belayneh  
Getachew Bogale  
Silas Araya



**Federal Democratic Republic of Ethiopia**  
**Ministry of Education**

**PEARSON**

## Acknowledgments

The development, printing and distribution of this student textbook has been funded through the General Education Quality Improvement Project (GEQIP), which aims to improve the quality of education for Grades 1–12 students in government schools throughout Ethiopia.

The Federal Democratic Republic of Ethiopia received funding for GEQIP through credit/financing from the International Development Associations (IDA), the Fast Track Initiative Catalytic Fund (FTI CF) and other development partners – Finland, Italian Development Cooperation, the Netherlands and UK aid from the Department for International Development (DFID). MOE/GEQIP/IDA/ICB/001/09  
The Ministry of Education wishes to thank the many individuals, groups and other bodies involved – directly and indirectly – in publishing the textbook and accompanying teacher guide.

The publisher would like to thank the following for their kind permission to reproduce their photographs:

(Key: b-bottom; c-centre; l-left; r-right; t-top)

**Alamy Images:** 3 (a), 3 (b), 55tr, 58bl, 65tr, 65bl, 110cl, 111tr, 121bl (field), 121br, 134tl, 176l, 180cr, 181tr, 185tr, 201c, 201cl (boar), 215bc, 217br, 218tl, 218cl, 232bl, 238bl, 243cr, 247cr, 258bl, 259cr, 261tr; Corbis: 175br, 177tl (Haldane), 191br, 216tl; **Getty Images:** 46cl, 235br, 243tr, 253cl, 253br, 259tr, 260bl; **iStockphoto:** 54bl, 67br, 68cl, 103c (b), 103cl (a); **Science Photo Library Ltd:** 3 (1.2a), 3 (1.2b), 3 (c), 4cl, 4cr, 5tr, 14tl, 14tr, 14cr, 14b, 18cr, 24bl, 47tr, 49cr, 49br, 78tl, 83br, 111tl, 119bl, 122l (male), 122r (female), 136cl, 153bl, 177tc (Oparin), 180, 180tl, 180bl, 215bl (a).

Cover images: Front: **Alamy Images:** bc; **iStockphoto;** **Science Photo Library Ltd**

All other images © Pearson Education

Every effort has been made to trace the copyright holders and we apologise in advance for any unintentional omissions. We would be pleased to insert the appropriate acknowledgement in any subsequent edition of this publication.

© Federal Democratic Republic of Ethiopia, Ministry of Education  
First edition, 2002 (E.C.)  
ISBN: 978-99944-2-014-8

Developed, Printed and distributed for the Federal Democratic Republic of Ethiopia, Ministry of Education by:  
Pearson Education Limited  
Edinburgh Gate  
Harlow  
Essex CM20 2JE  
England

In collaboration with  
Shama Books  
P.O. Box 15  
Addis Ababa  
Ethiopia

Second Edition 2007 (E.C.),  
By Tan Prints India Pvt. Ltd.

All rights reserved; no part of this publication may be reproduced, stored in a retrieval system, or transmitted in any form or by any means, electronic, mechanical, photocopying, recording, or otherwise without the prior written permission of the copyright owner or a licence permitting restricted copying in Ethiopia by the Federal Democratic Republic of Ethiopia, Federal Negarit Gazeta, *Proclamation No. 410/2004 Copyright and Neighboring Rights Protection Proclamation, 10th year, No. 55, Addis Ababa, 19 July 2004.*

### Disclaimer

Every effort has been made to trace the copyright owners of material used in this document. We apologise in advance for any unintentional omissions. We would be pleased to insert the appropriate acknowledgement in any future edition

Printed in Malaysia (CTP-VVP)

# Contents

---

<b>Unit 1 Micro-organisms</b>	<b>1</b>
1.1 Bacteria	3
1.2 The ecology and uses of bacteria	11
1.3 What are viruses?	26
<b>Unit 2 Ecology</b>	<b>44</b>
2.1 Cycling matter through ecosystems	45
2.2 Ecological succession	54
2.3 Biomes	58
2.4 Biodiversity	63
2.5 Populations	80
<b>Unit 3 Genetics</b>	<b>101</b>
3.1 Genetic crosses	102
3.2 Molecular genetics	128
3.3 Protein synthesis	142
3.4 Mutations	152
<b>Unit 4 Evolution</b>	<b>170</b>
4.1 The origin of life	171
4.2 Theories of evolution	183
4.3 The evidence for evolution	191
4.4 The processes of evolution	204
4.5 The evolution of humans	213
<b>Unit 5 Behaviour</b>	<b>231</b>
5.1 An introduction to behaviour	231
5.2 Innate behaviour	238
5.3 Learned behaviour	246
5.4 Examples of behaviour patterns	256
<b>Index</b>	<b>271</b>



Contents	
Section	Learning competencies
1.1 Bacteria (page 3)	<ul style="list-style-type: none"><li>• Name, describe and give examples of the different types of micro-organism.</li><li>• Describe the structure of a bacterial cell.</li><li>• Describe the shapes of different types of bacteria.</li><li>• Classify bacteria as Gram-positive and Gram-negative.</li></ul>
1.2 The ecology and uses of bacteria (page 11)	<ul style="list-style-type: none"><li>• Appreciate that bacteria are found in many diverse locations.</li><li>• Explain that bacteria are important disease-causing agents; are used in industrial processes and give examples of industrial processes that use bacteria; and are involved in the cycling of mineral elements such as carbon and sulphur.</li><li>• Describe the main groups of micro-organisms.</li><li>• Explain the roles of reservoirs of infection in the transmission of infectious diseases caused by bacteria.</li><li>• Explain the roles that bacteria play in every ecosystem.</li><li>• Explain how bacteria produce disease.</li><li>• Compare infectious disease with functional disease and state the germ theory.</li><li>• State the role of bacteria in recombinant DNA work.</li><li>• Define cloning and illustrate how foreign genes are inserted in bacterial pyramids, and how bacteria are used as vectors.</li></ul>

Contents	
Section	Learning competencies
1.3 What are viruses?	<ul style="list-style-type: none"> <li>• Describe the structure of a virus, draw and label it.</li> <li>• Explain the different forms of viruses and diagram them.</li> <li>• Classify viruses and give examples of RNA, DNA, and retroviruses.</li> <li>• Discuss the reproductive cycles of viruses and compare the lytic and lysogenic cycles of viral reproduction.</li> <li>• Draw and label a bacteriophage.</li> <li>• Compare viruses with free-living cells.</li> <li>• Draw, label and describe the structure of HIV, show the structure of glycoprotein-120 on its surface and tell that it is this protein that allows HIV to bind with CD4 lymphocytes.</li> <li>• Explain the life cycle of HIV, show how it replicates.</li> <li>• Explain how different anti-retroviral drugs work and tell why HAART is more effective than single drug treatment.</li> <li>• State the social and economic impacts of AIDS.</li> <li>• Demonstrate the life skills that lead to responsible sexual behaviour.</li> </ul>

## 1.1 Bacteria

By the end of this section you should be able to:

- Name, describe and give examples of the different types of micro-organism.
- Describe the structure of a bacterial cell.
- Describe the shapes of different types of bacteria.
- Classify bacteria as Gram-positive and Gram-negative.

### What different types of micro-organisms are there?

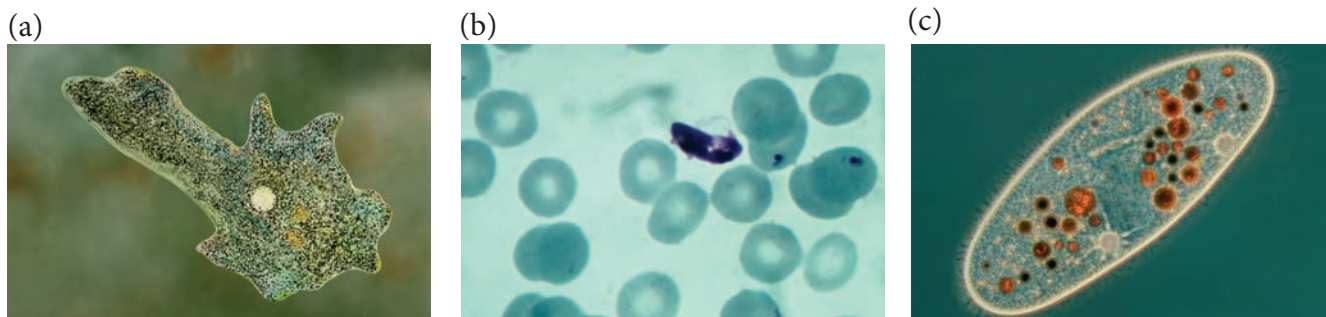
Any **micro-organism** is just what its name suggests – a very small organism. Most micro-organisms are unicellular (the whole organism consists of just one cell), although some do contain more than one cell.

There are five main groups of micro-organisms, although each group can be subdivided. These groups are:

- protozoa
- some **fungi**
- some algae
- viruses
- bacteria

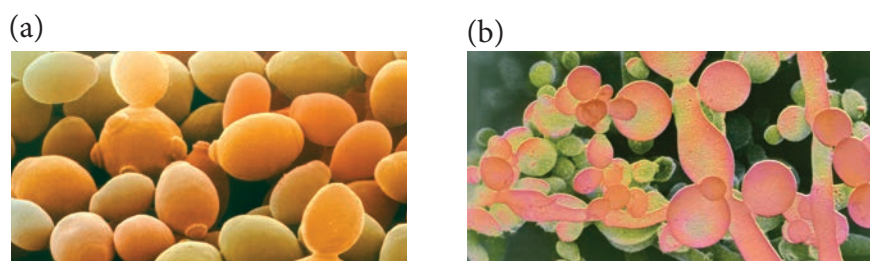
### Protozoa, fungi and algae

Protozoa are **unicellular** organisms that lack a cell wall. Most of them are motile (able to move), and include organisms such as *Amoeba*, *Plasmodium* (the organism that causes malaria), and *Paramecium*.



**Figure 1.1** Some protozoa. (a) Amoeba; (b) Plasmodium in blood cells; (c) Paramecium

The only unicellular fungi are the **yeasts**. These include brewer's yeast and baker's yeast (*Saccharomyces*) as well as the yeast-like organism that causes thrush in humans (*Candida*).



**Figure 1.2** Some yeasts. (a) *Saccharomyces*; (b) *Candida*

### KEY WORDS

**micro-organism** a very small organism, usually having just one cell

**fungus** (plural **fungi**) a eukaryotic organism that obtains its nutrition using extracellular digestion. A fungus is neither a plant nor an animal

**unicellular** a unicellular organism has just one cell

**multicellular** a multicellular organism has more than one cell

**yeast** a type of fungi used for brewing and baking

**KEY WORDS**

**mycelium** the collection of very fine strands that makes up a fungus. Each strand is called a **hypha** (plural **hyphae**). The **hyphae** are not 'compartmentalised' into cells; each is 'multinucleate' – the cytoplasm contains many nuclei

**alga** (plural **algae**) an **alga** is a single-celled organism that obtains its nutrition using photosynthesis.

**motile** an organism that is able to move on its own

Although the yeasts are the only unicellular fungi, other fungi are also classed as micro-organisms. Many fungi produce a **mycelium** of microscopic strands called **hyphae**. They release enzymes from these strands that digest whatever the fungus is growing on. The products of digestion are then absorbed into the fungus to help with its growth and reproduction. Remember, fungi do not have true roots, stems and leaves. Some fungi live on or in living organisms, as parasites. Others live on dead material as saprobionts, organisms that digest their food externally and absorb the products.

**Algae** are an important group of organisms. Many are large (the seaweeds are all algae), but some algae are unicellular. The unicellular algae in figure 1.4 are part of the plankton, the collections of small microscopic plant and animal organisms that float or drift in large numbers in fresh or salt water, providing food for fish and other larger organisms. These unicellular algae in the oceans produce far more oxygen during photosynthesis than all the forests in the world together.

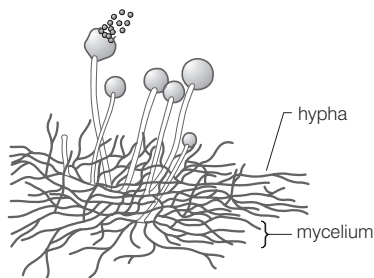


Figure 1.3 Fungal hyphae

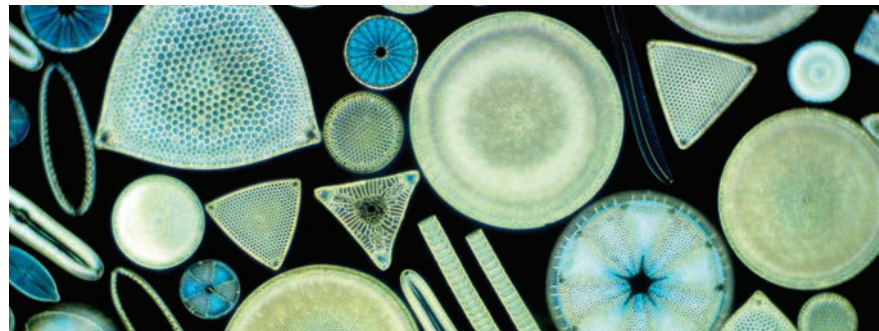


Figure 1.4 Unicellular algae are found in the ocean as plankton.



Figure 1.5 Chlamydomonas moves using its two flagella.

Some unicellular algae are **motile** – they can move. Figure 1.5 shows an alga called *Chlamydomonas*, which has two flagella at one end to propel it through the water.

Viruses are sometimes referred to as micro-organisms, although some biologists say that, strictly, they are not organisms at all.

Viruses cannot independently carry out any of the processes common to all living organisms. They can only reproduce inside other cells. So they are all parasites. Some parasitise bacteria, some parasitise plants and others parasitise animals. The basic virus is not even a cell – it has no nucleus and no cytoplasm – but it does have genetic material surrounded by a protein coat.

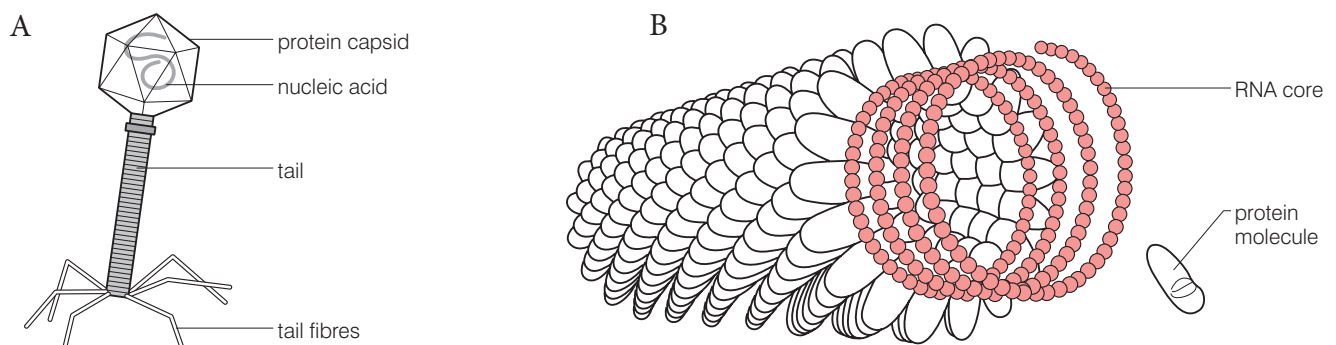


Figure 1.6 Some viruses. A Bacteriophages are viruses that parasitise bacteria; B Tobacco mosaic virus parasitises tobacco plants.

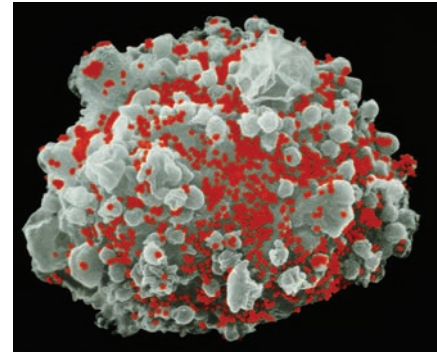


**Activity 1.1: What micro-organisms do you know?**

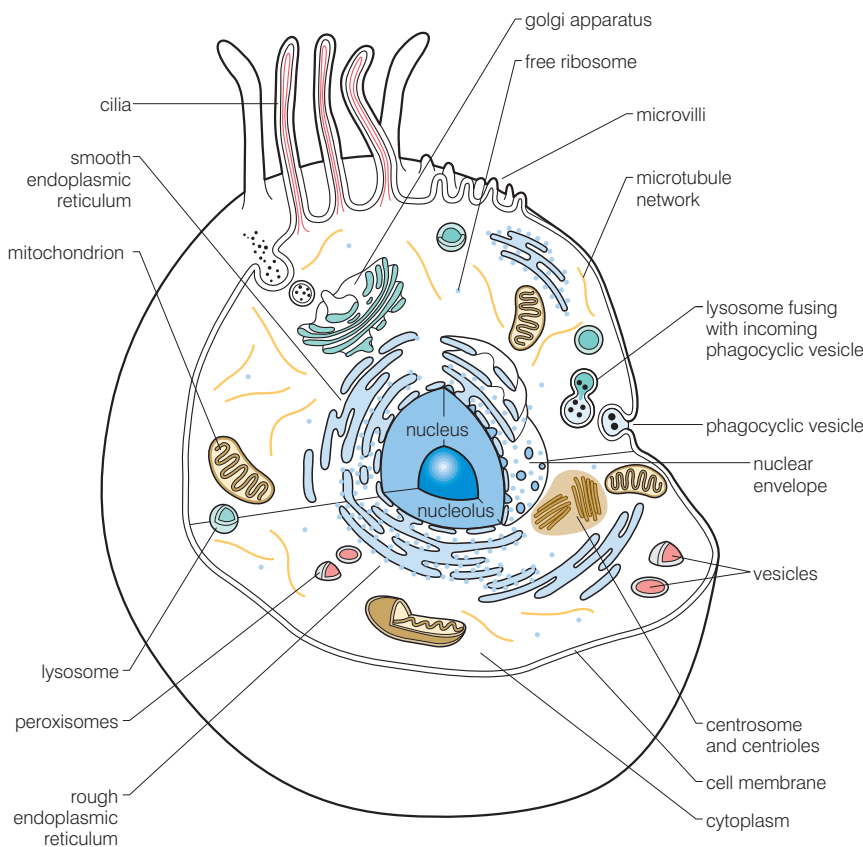
Try to find one species of each type of micro-organism (bacteria, protozoa, algae, fungi and viruses) that is useful, and one that is harmful. You may not be successful for all types in both cases. Explain why.

**What are bacterial cells like?**

You already know about the structure of plant and animal cells. Biologists call these **eukaryotic cells**. Fungi and protists (algae and protozoa) also have eukaryotic cells.



**Figure 1.7** HIV is a virus that parasitises human white blood cells, causing the symptoms of AIDS.



**Figure 1.8** The structure of a eukaryotic cell

Bacteria, however, have **prokaryotic cells**. In prokaryotic cells there is no true nucleus separated from the rest of the cell by a membrane. Instead, the DNA of the bacterium forms a continuous loop that is intermingled with the cytoplasm.

Figure 1.9 shows the structure of a generalised **bacterial** cell. Not all bacteria have all the structures shown in the diagram. For example, not all bacteria have a capsule and many do not have a flagellum.

All bacteria do have a cell wall (but it is not made from cellulose like plant cell walls and instead is made from a substance called peptidoglycan, which makes it rigid), a cell membrane, cytoplasm, ribosomes and DNA.

**KEY WORDS**

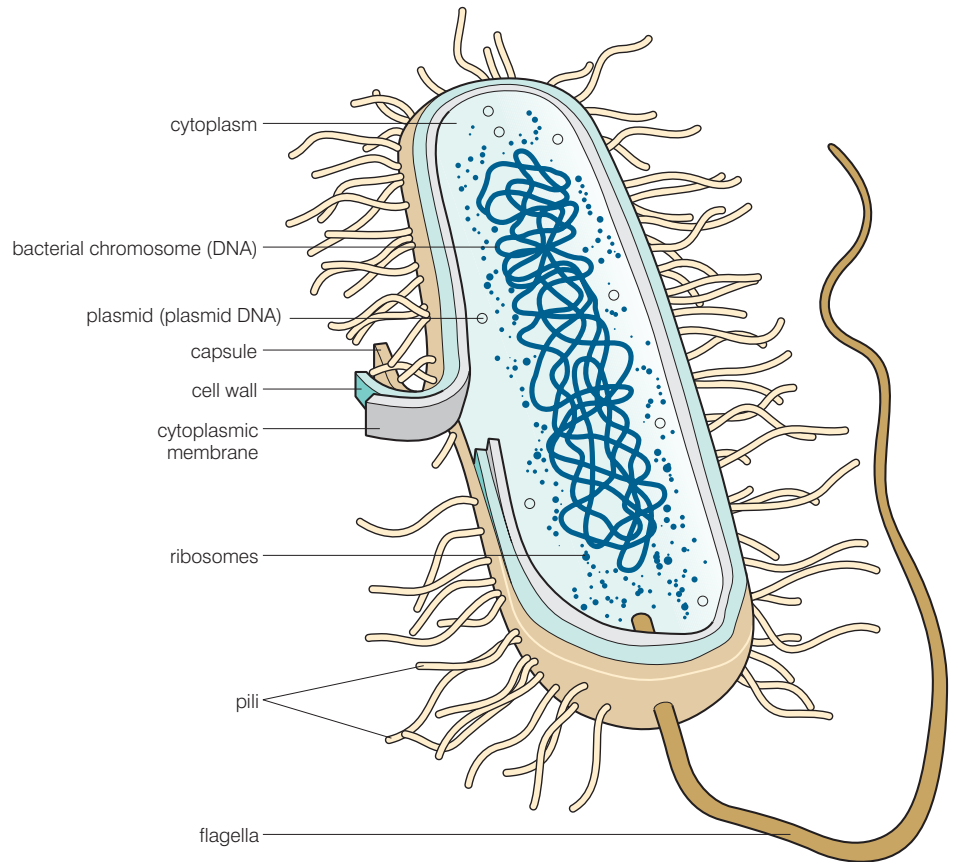
**eukaryotic cell** a type of cell that has a nucleus. The word eukaryotic is derived from Greek eu (true) and karyos (nuclear)

**prokaryotic cell** a type of cell that does not have a nucleus. Only bacteria have prokaryotic cells. The word prokaryotic is derived from Greek pro (before) and karyos

**bacterium** (plural **bacteria**) a micro-organism consisting of just one prokaryotic cell

**Activity 1.2**

Work in small groups and brainstorm all the differences you can think of between eukaryotic and prokaryotic cells. Make a table comparing the two different types of cells and share your ideas with the rest of the class.



**Figure 1.9** The structure of a bacterial cell

Although bacterial cells vary a great deal in size, they are usually much smaller than eukaryotic cells. Bacterial cells are usually between 1 and 10  $\mu\text{m}$  long, whereas eukaryotic cells are between 10 and 100  $\mu\text{m}$  long. (1  $\mu\text{m}$  is 0.001 mm, one-thousandth of one millimetre.)

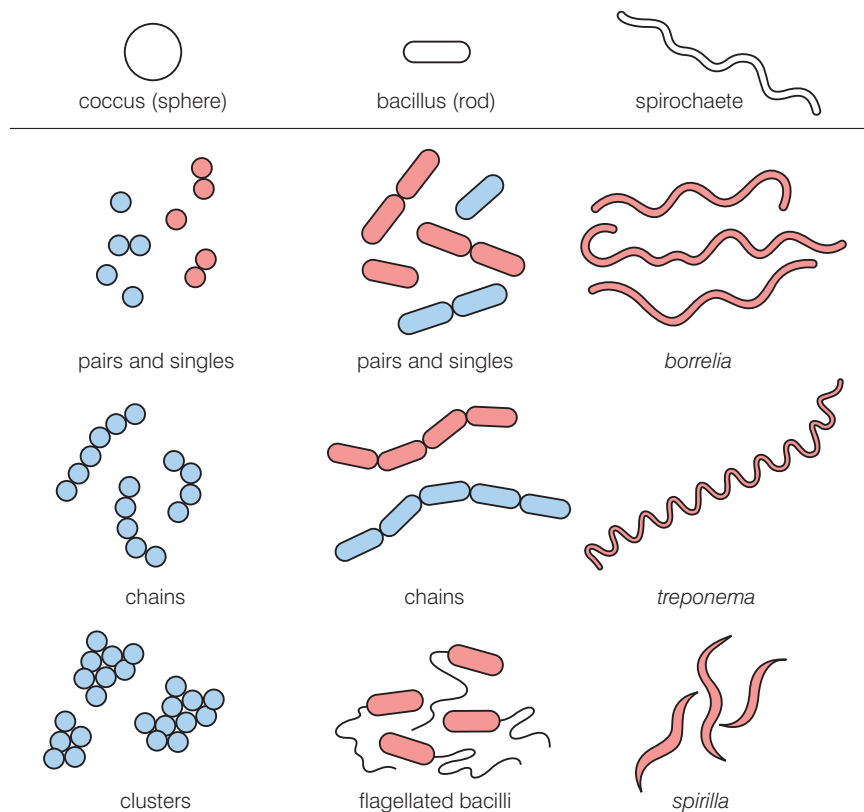
**DID YOU KNOW?**

The nucleus, mitochondria and chloroplasts found in eukaryotic cells are all surrounded by a double membrane. They are sometimes called ‘membrane-bound organelles’. So, biologists sometimes say that prokaryotic cells do not contain membrane-bound organelles. Because of this, photosynthesis and respiration are carried out differently in bacterial cells. Photosynthesis takes place in the plasma membrane or membranes in the cytoplasm. Many of the reactions of respiration take place in the cytoplasm, with some also occurring on the plasma membrane.

## Are all bacteria the same shape?

No – there are several shapes, sizes and arrangements. Bacterial cells come in three main shapes:

- cocci (singular, coccus) – spherical bacteria
- bacilli (singular, bacillus) – rod-shaped bacteria
- spirochaetes – spiral or corkscrew-shaped bacteria



**Figure 1.10** Bacterial cells come in three main shapes.

Whatever their shape, bacterial cells are sometimes found singly; sometimes two cells are stuck together; and sometimes the cells exist in chains.

### Activity 1.3: Finding out more about bacteria

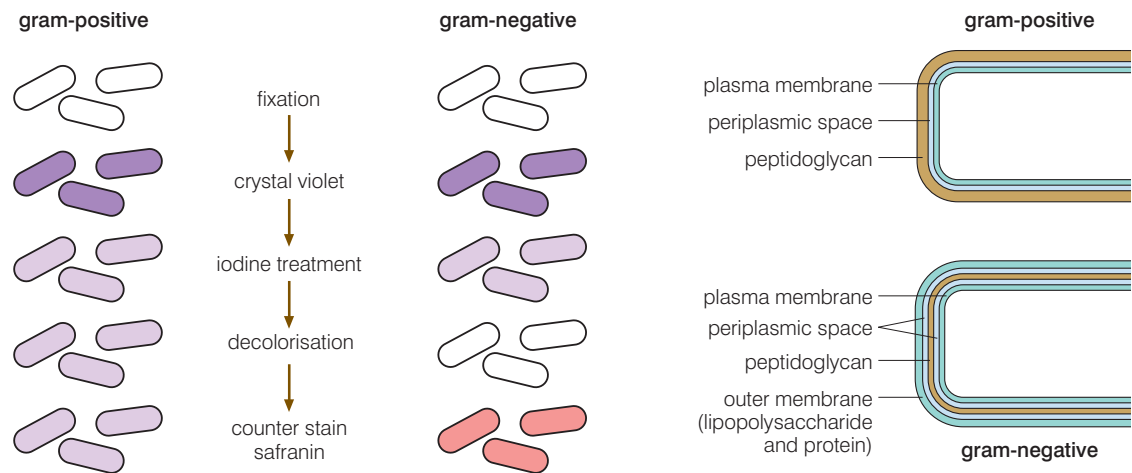
*Streptococcus* and *Lactobacillus* are two well-researched types of bacteria. Carry out a library search to find out what shapes these two bacteria have, and why they are so important to us. Also, try to find two diseases caused by spiral-shaped bacteria.

## Are there other ways of classifying bacteria?

Bacteria can be classified in other ways, besides their shape. One of these ways is whether or not they are coloured by Gram's stain. This test gives two categories:

- **Gram-positive** – these bacteria are stained purple by **Gram’s stain**
- **Gram-negative** – these bacteria are stained pink by Gram’s stain

Because Gram’s stain produces different results with different types of bacteria, it is called a **differential stain**.



**Figure 1.11** Gram staining

**KEY WORDS**

**Gram’s staining** a test for classifying bacteria (named after Hans Christian Gram, who developed the technique in 1884)

**differential stain** a test that uses staining to classify organisms or organic material

**peptidoglycan** a complex molecule made from sugars and amino acids. It has a mesh-like structure and is found in bacterial cell walls

**endotoxins** toxins found in some bacteria

The difference is due to the structure of the cell wall of the different bacteria. Gram-negative bacteria have much less **peptidoglycan** in their cell walls. This is the part of the wall that absorbs the stain. They also have a membrane outside the peptidoglycan cell wall, which Gram-positive bacteria do not have. This outer membrane secretes **endotoxins** (a type of toxin that is a structural component of these bacteria) and is also quite resistant to many antibiotics. This makes diseases caused by Gram-negative bacteria more difficult to treat. Gram-negative bacteria, on the whole, cause more serious diseases, although there are exceptions – the bacterium that causes tuberculosis is a Gram-positive bacterium.

Gram staining is used much less than it was in diagnosing disease, as more advanced and more reliable biochemical techniques have become available.

**Activity 1.4: Looking at bacteria in yoghurt**

**You will need:**

- a microscope
- a slide and coverslip
- yoghurt
- water
- a dropping pipette

**Method**

1. Take a small sample of yoghurt using the pipette, and place it on a slide.
2. If the sample seems too thick, dilute it with a drop of water.
3. Lower a coverslip onto the yoghurt, taking care not to produce air bubbles.
4. First, observe the bacteria at low power ( $\times 100$ ) to find a good place to start looking. The diaphragm setting should be very low (small) because these bacteria are almost transparent.
5. Switch to the highest power to identify the bacteria according to the shape of cells and arrangement of the cells (pairs, clusters, chains, etc.).
6. Make a drawing of the different bacteria you can see.

**Review questions**

Choose the correct answer from A to D.

1. Protozoa are:
  - A multicellular organisms
  - B one-celled animals
  - C members of the group protoctista
  - D unicellular plants
2. Micro-organisms include:
  - A bacteria and some fungi
  - B viruses
  - C protozoa
  - D all of the above
3. Viruses are sometimes not considered as living organisms because:
  - A they do not have any of the organelles found in cells
  - B they are incapable of independent reproduction
  - C they cannot carry out any metabolic processes
  - D all of the above

4. Gram's stain is called a differential stain because:
  - A it stains bacterial cells, but not fungi
  - B it stains some bacteria purple and others pink
  - C it stains viruses, but no other organisms
  - D it stains some fungal cells purple and others pink
5. Bacterial cells are different from animal cells because the bacterial cells:
  - A are larger than animal cells
  - B have no nucleus
  - C have no DNA
  - D have no cytoplasm
6. The three main shapes of bacterial cell are:
  - A diplococci, staphylococci and bacilli
  - B diplococci, streptococci and bacilli
  - C diplococci, streptococci and staphylococci
  - D cocci, bacilli and spirochaetes
7. Compared with Gram-positive bacteria, Gram-negative bacteria:
  - A have an extra membrane outside the cell wall
  - B are more resistant to antibiotics
  - C produce more dangerous endotoxins
  - D all of the above
8. Viruses can parasitise:
  - A only animal cells
  - B only plant cells
  - C only bacterial cells
  - D animal cells, plant cells and bacterial cells
9. It is true to say of bacterial cells that:
  - A none can photosynthesise
  - B only some can respire
  - C none contain ribosomes
  - D none contain chloroplasts
10. Membrane-bound organelles include:
  - A the nucleus
  - B chloroplasts
  - C mitochondria
  - D all of the above

## 1.2 The ecology and uses of bacteria

By the end of this section you should be able to:

- Appreciate that bacteria are found in many diverse locations.
- Explain that bacteria are important disease-causing agents; are used in industrial processes and give examples of industrial processes that use bacteria; and are involved in the cycling of mineral elements such as carbon and sulphur.
- Describe the main groups of micro-organisms.
- Explain the roles of reservoirs of infection in the transmission of infectious diseases caused by bacteria.
- Explain the roles that bacteria play in every ecosystem.
- Explain how bacteria produce disease.
- Compare infectious disease with functional disease and state the germ theory.
- State the role of bacteria in recombinant DNA work.
- Define cloning and illustrate how foreign genes are inserted in bacterial plasmids, and how bacteria are used vectors in the genetic engineering of plants.

### Where are bacteria found?

Bacteria are found in every ecosystem – they are pretty well everywhere around you – and everywhere inside you as well! There are ten bacterial cells inside you for every one of your own cells. Most of these are found in the large intestine.

Bacteria are important because they:

- cause diseases
- are used in many industrial processes
- recycle mineral elements such as carbon, nitrogen and sulphur through ecosystems

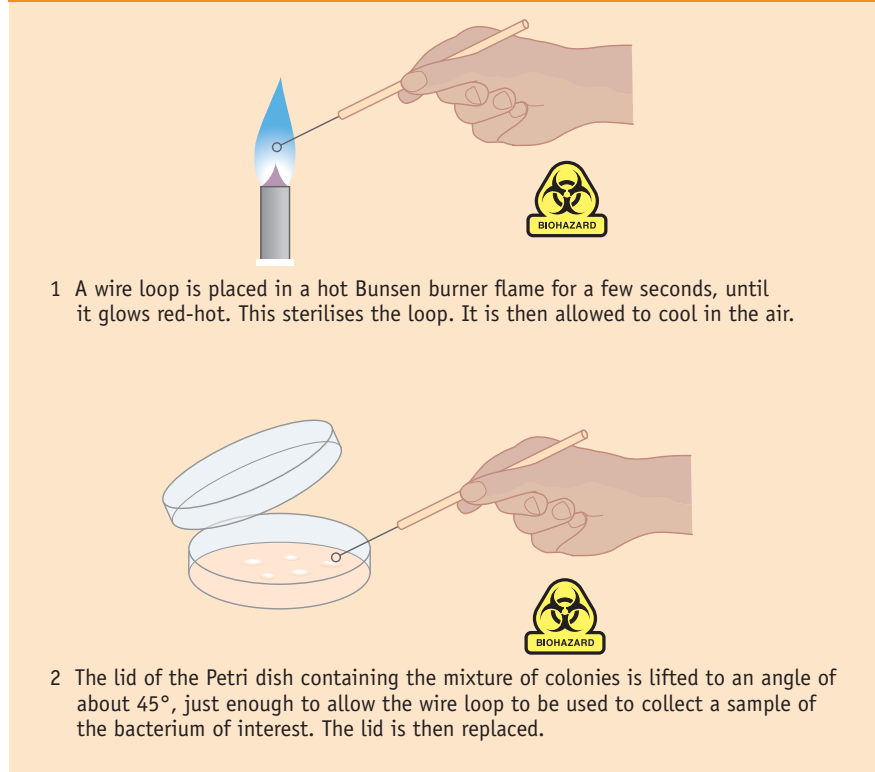
**KEY WORDS**

**germ theory** says that infectious diseases are caused by micro-organisms

**pathogen** the term describes any organism that causes disease

**infectious disease** an infectious disease is caused by a living organism entering or infecting another living organism. They are sometimes called communicable diseases because they can be transmitted or communicated from one person to another

**Activity 1.5: Culturing micro-organisms from the environment**



*Figure 1.12 Culturing micro-organisms.*

**What is the role of bacteria and other microorganisms in infectious diseases?**

As we have already learned, the theory that some diseases are caused by the invasion of the body by micro-organisms was put forward by the French chemist and microbiologist Louis Pasteur. The English surgeon Joseph Lister and the German physician Robert Koch were also involved in the development of this theory. In the mid-19th century, Pasteur showed that micro-organisms in the air caused wine to go 'sour'. In the 1860s, Lister showed that carbolic acid (phenol) acted as a disinfectant, and prevented disease in bones following surgery. In 1880, Robert Koch identified the micro-organisms that cause tuberculosis and cholera.

The theory that disease can be caused by micro-organisms is called the **germ theory**. Organisms that cause disease are called **pathogens**. A disease that is caused by a micro-organism infecting the body is an **infectious disease**.

**Koch's postulates**

After considerable work on micro-organisms as the cause of disease, Robert Koch put forward the following ideas (or 'postulates') that should always apply if a certain micro-organism causes a disease.



- The micro-organism must always be present when the disease is present, and should not be present if the disease is not present.
- The micro-organism can be isolated from an infected person and then grown in culture.
- Introducing such cultured micro-organisms into a healthy host should result in the disease developing.
- It should then be possible to isolate the micro-organism from this newly diseased host and grow it in culture.

The first postulate establishes a link between the micro-organism and the disease. The following three postulates prove that the metabolism of a specific living micro-organism, when transferred into a healthy host, causes the disease.

Different micro-organisms cause disease in different ways, as shown in table 1.1.

**Table 1.1** How micro-organisms cause disease

Type of micro-organism	How the micro-organism causes disease	Examples of diseases caused
Bacteria	Bacteria release toxins as they multiply. These toxins affect cells in the region of the infection, and sometimes in other regions of the body as well. Bacterial diseases can be treated with antibiotics, as each bacterium is a true cell with its own metabolic systems, and is capable of cell division. Some bacteria invade and grow in the tissues of organs, causing physical damage.	Pneumonia, cholera, pulmonary tuberculosis (TB)
Viruses	Viruses enter living cells and disrupt the metabolic systems of the cell. The genetic material of the virus becomes incorporated with that of the cell and instructs the cell to produce more viruses. Viruses cannot be treated with antibiotics as they are not true cells and are only active inside cells, which antibiotics cannot enter.	Influenza ('flu), AIDS, measles, common cold
Fungi	When fungi grow in or on living organisms, their hyphae secrete enzymes. These digest substances in the tissues, and the substances produced are absorbed. Growth of hyphae also physically damages the tissue. Some fungi also secrete toxins. Others can cause an allergic reaction (e.g. farmer's lung).	Athlete's foot, farmer's lung
Protozoa	Protozoa cause disease in many different ways.	Malaria, sleeping sickness

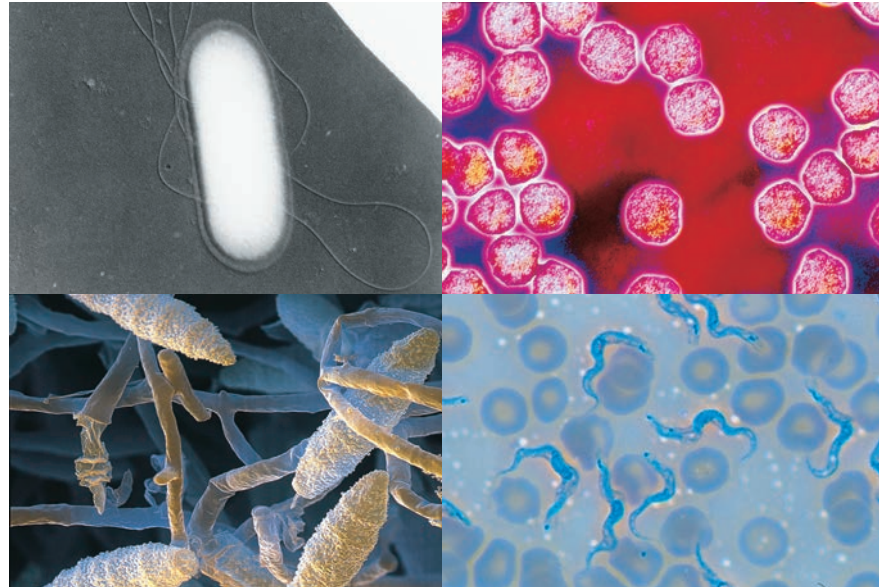


Figure 1.13 Types of disease-causing organism

**KEY WORD**

**reservoir of infection** *this is any person, animal, plant, soil or substance in which an infectious agent normally lives and multiplies. The reservoir typically harbours the infectious agent without showing symptoms of the disease and serves as a source from which other individuals can be infected. People acting as the reservoir of infection are sometimes called carriers of the disease*

**How are disease-causing micro-organisms transmitted?**

Table 1.1 looked at how bacteria cause disease. There must clearly be a source of infection. The origin of micro-organisms that infect other people is called the **reservoir of infection**. This is the principal habitat from which an infectious agent may spread to cause disease. Reservoirs of infection include:

- human beings – the reservoir for many diseases, including the common cold, diphtheria and others
- other animals – for example: chickens, the reservoir for salmonella infections; mosquito, the reservoir for malaria
- soil – the reservoir for tetanus and many other pathogens
- water – the reservoir for Legionnaire’s disease, amoeba, cholera, etc.
- food – the reservoir for many diseases including typhoid
- contaminated objects – contact infections such as HIV/AIDS and trachoma
- air – the reservoir for pneumonia, tuberculosis, etc.



Figure 1.14 Airborne droplet infection

Because there are different reservoirs of disease-causing organisms, there are several different ways in which diseases can be transmitted, as shown in table 1.2.

**Table 1.2** How diseases can be transmitted

Method of transmission	How the transmission route works	Examples of diseases
Droplet infection	Many of these diseases are 'respiratory diseases' – diseases affecting the airways of the lungs. The organisms are carried in tiny droplets through the air when an infected person coughs or sneezes. They are inhaled by other people.	Common cold, 'flu, pneumonia
Drinking contaminated water	The micro-organisms transmitted in this way often infect regions of the gut. When unclean water containing the organisms is drunk, they colonise a suitable area of the gut and reproduce. They are passed out with faeces and find their way back into the water.	Cholera, typhoid fever
Eating contaminated food	Most food poisoning is bacterial, but some viruses are transmitted this way. The organisms initially infect a region of the gut.	Salmonellosis, typhoid fever, listeriosis, botulism
Direct contact	Many skin infections, such as athlete's foot, are spread by direct contact with an infected person or contact with a surface carrying the organism.	Athlete's foot, ringworm
Sexual intercourse	Organisms infecting the sex organs can be passed from one sexual partner to another during intercourse. Some are transmitted by direct body contact, such as the fungus that causes candidiasis (thrush). Others are transmitted in semen or vaginal secretions, such as the AIDS virus. Some can be transmitted in saliva, such as syphilis.	Candidiasis, syphilis, AIDS, gonorrhoea
Blood-to-blood contact	Many of the sexually transmitted diseases can also be transmitted by blood-to-blood contact. Drug users sharing an infected needle can transmit AIDS.	AIDS, hepatitis B
Animal vectors	Many diseases are spread through the bites of insects. Mosquitoes spread malaria and tsetse flies spread sleeping sickness. In both cases, the disease-causing organism is transmitted when the insect bites humans in order to suck blood. Flies can carry micro-organisms from faeces onto food.	Malaria, sleeping sickness

### Activity 1.6: Identifying sources of infection

For each of the methods of transmission given in table 1.2, identify the reservoir of infection.

**DID YOU KNOW?**

Eating too much food can result in obesity, which is regarded as a disease condition in itself, and can also lead to other diseases such as coronary heart disease.

**What other types of disease are there?**

Before we answer that question, we should really define what we mean by ‘disease’.

The World Health Organization’s definition of health is ‘a state of complete physical, mental and social well-being’. But disease is less easy to define. It doesn’t mean just the absence of perfect health. If we are less fit than we might be, or if we are feeling depressed at the thought of too much schoolwork, that doesn’t necessarily mean we have a disease.

A useful definition of disease might be ‘a condition with a specific cause in which part or all of a body is made to function in a non-normal and less efficient manner’. This definition could include diseases of all organisms – including plants. It could also include physical, mental and social aspects of disease in humans.

Infectious disease is just one type of disease. Disease can be caused by a number of other factors.

- A person’s lifestyle and working conditions may result in **human-induced diseases**. Examples include many cancers, together with some forms of heart disease and fibrosis.
- Degenerative processes are often the result of ageing. Arthritis and atherosclerosis are examples of **degenerative diseases**.
- Our genes may lead to disease. Haemophilia and sickle-cell disease are examples of **genetic diseases**.
- Lack of nutrients in our diet may lead to **deficiency diseases**, including scurvy (caused by a lack of vitamin C) and kwashiorkor (caused by a lack of protein).
- Social activities can lead to disease. **Social diseases**, including alcoholism and drug addiction, may result in dependency on the drug, isolation, clinical depression and various levels of antisocial behaviour.

**KEY WORDS**

**Human induced diseases** are diseases that arise as a result of a person’s lifestyle

**Degenerative diseases** often result from the ageing process during which the affected tissues deteriorate over time due to simple ‘wear and tear’

**Genetic diseases** are diseases that result from the action of mutated genes

**Deficiency diseases** are diseases that result from a lack of a nutrient in our diet.

**Social diseases** are conditions that result from social activities and may lead to socially unacceptable behaviour

**Multifactorial** describes a condition that is affected by the interaction of many factors

**Categorising diseases**

In many cases, it is an oversimplification to place a disease in just one category. For example, atherosclerosis (laying down fatty substances in arteries) increases as we age, so it can be classified as a degenerative disease. But our diet influences this process. If we eat more saturated fat, more fatty substances are laid down in our arteries. There is also a genetic component – some people are at increased risk of this disease because of genes inherited from their parents. Stress and high blood pressure increase the rate at which atherosclerosis develops, and these can be the result of our lifestyle. Clearly, atherosclerosis does not fit neatly into any one category. It is best to consider such conditions as **multifactorial**.

### Functional diseases

In some cases, there is an obvious 'malfunction' of an organ or system, without there being any obvious damage or physical sign of disease in the organ. Because of the malfunction, these diseases are called functional diseases, for example, heart disease.

Several intestinal conditions fall into this category. In many forms of Irritable Bowel Syndrome (IBS), there is no sign of damage or disease in the large intestine, yet the large intestine does not function normally.

Myalgic Encephalopathy (ME or Chronic Fatigue Syndrome) is another functional disease. In this condition, for no apparent reason, the sufferer is drained of all energy and the simplest task can be an extreme effort.

However, some biologists believe that there must be some kind of abnormality in the organs involved in functional diseases. For example, there is some evidence to suggest that, in ME, many of the mitochondria (which release energy in respiration) are abnormal. If this is true, then it may be that functional diseases are really just like other forms of disease, but the precise cause is yet to be discovered.

## The role of bacteria in an ecosystem

### The role of bacteria in recycling minerals through ecosystems

Many bacteria are decomposers. When organisms die, these bacteria break down the complex molecules that are found in the bodies of the dead organisms into much simpler molecules. The bacteria use some of these for their own metabolism, but in the process they release some minerals, in various forms, into the environment. Many elements are recycled in this way, including:

- carbon
- nitrogen
- sulphur
- phosphorus

Here we will look at how nitrogen and sulphur are recycled.

### The nitrogen cycle

The element nitrogen is found in many important organic molecules in all living organisms. These include:

- proteins
- DNA
- RNA
- ATP

and many others.

It is important that once organisms die, the nitrogen they contain is made available again to other organisms. Several different types of bacteria are involved in this recycling of nitrogen.

### DID YOU KNOW?

We describe the conversion of ammonium ions to nitrate ions as oxidation because in the process oxygen is gained and hydrogen ions are lost.

### Activity 1.7

Plan a presentation which you can give to younger students explaining the different ways they can catch infectious diseases, and suggesting ways to avoid the spread of disease.

The nitrogen cycle will be treated in detail in Unit 2, but table 1.3 below shows the main bacteria involved and the roles they play.

**Table 1.3** The role of bacteria in the nitrogen cycle

Micro-organism	Process
Nitrogen-fixing bacteria, e.g. <i>Rhizobium</i>	Nitrogen gas is fixed into forms other organisms can use (e.g. ammonium).
Ammonifying bacteria (decomposers)	The decomposers break down proteins in dead organisms and animal waste releasing ammonium ions, which can be converted to nitrates.
Nitrifying bacteria, e.g. <i>Nitrosomonas</i> and <i>Nitrobacter</i>	Nitrification is a two-step process. Ammonia or ammonium ions are oxidised first to nitrites ( <i>Nitrosomonas</i> ) and then to nitrates ( <i>Nitrobacter</i> ) which is the form most usable by plants.
Denitrifying bacteria, e.g. <i>Pseudomonas</i>	Nitrates are reduced to nitrogen gas, returning nitrogen to the air and reducing the amount of nitrogen in the soil.



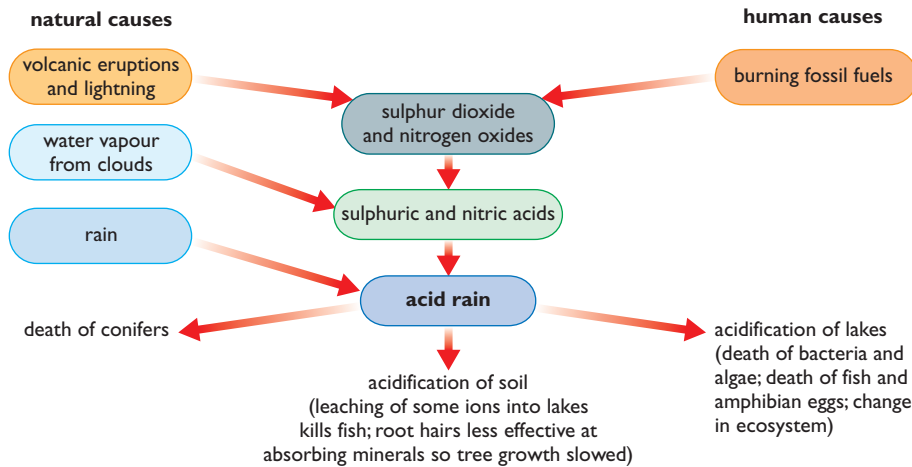
**Figure 1.15** Root nodules

### The sulphur cycle

Sulphur is found in fewer types of organic molecule than nitrogen, but it is found in many proteins. The sulphur cycle will be covered in detail in Unit 2, but table 1.4 below shows the bacteria involved in the cycle and the roles they play.

**Table 1.4** The role of bacteria in the sulphur cycle

Reaction	Bacteria involved	Conditions needed	Process
Decomposition	<i>Desulphovibrio</i>	Anaerobic	Sulphur is released from proteins of dead matter as hydrogen sulphide (giving the 'rotten eggs' smell).
Oxidation of hydrogen sulphide	Photosynthetic sulphur bacteria	Anaerobic	Hydrogen sulphide is oxidised to release sulphur.
Oxidation of sulphur	Non-photosynthetic sulphur bacteria	Aerobic	Sulphur is oxidised to sulphate ions.



**Figure 1.16** Acid rain has many serious effects on living organisms, and can also corrode stone and metal over a long period.

If the populations of bacteria that are involved in the nitrogen cycle and the sulphur cycle were reduced, then the cycling of these elements could not occur, and all life would be impossible as a result. It is worth thinking about. We are made from atoms and molecules that have been in many other bodies before they were in ours. The micro-organisms that recycle carbon, nitrogen, sulphur and all the other minerals make them available again ... and again ... and again ...

### Activity 1.8

Investigate the negative effects of acid rain and ways in which it can be prevented or the effects on the environment reduced.

## How are bacteria used in industrial processes?

### Food and beverage fermentation

Bacteria and other micro-organisms have been used in manufacturing processes for thousands of years. They have been used to make:

- bread
- alcohol
- irgo or yoghurt
- vinegar

as well as many other products.

They have also been used in key processes such as sewage treatment.

**DID YOU KNOW?**

*Acetobacter* gets its name from the old name for ethanoic acid, which used to be called acetic acid.

**KEY WORD**

**antibiotic** a drug that kills bacteria

**Production of vinegar**

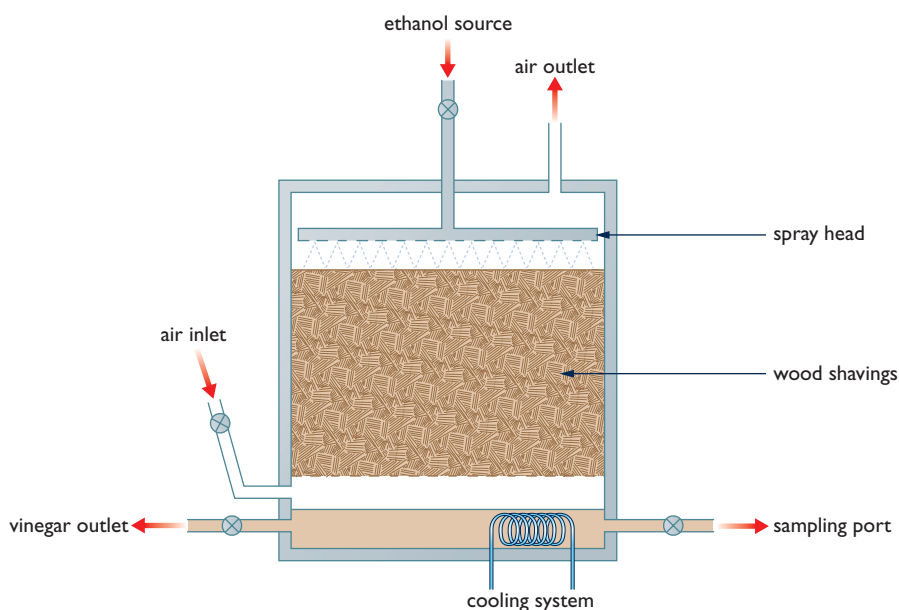
Vinegar is a dilute solution of ethanoic acid in water. It also contains other substances that give the vinegar its flavour. Vinegar is used in two main ways:

- to flavour foods
- to preserve foods

Vinegar is too acidic for most micro-organisms to grow and multiply, so keeping foods in vinegar is a good way of preserving them. We call this method of preserving food pickling.

Vinegar is produced by fermenting beer, wine or cider for a second time. A culture of a special bacterium called *Acetobacter* is used. The alcohol in the beer, wine or cider is oxidised to ethanoic acid.

This takes place in a special fermenter. The fermenter is filled with wood shavings and the alcohol source is sprayed in from the top. It trickles down through the wood shavings, which are covered with *Acetobacter* bacteria. As the liquid flows past them, the bacteria oxidise the alcohol to ethanoic acid. Air is blown in at the bottom to supply the oxygen the bacteria need. The vinegar drips out at the bottom of the wood shavings and is tapped off.



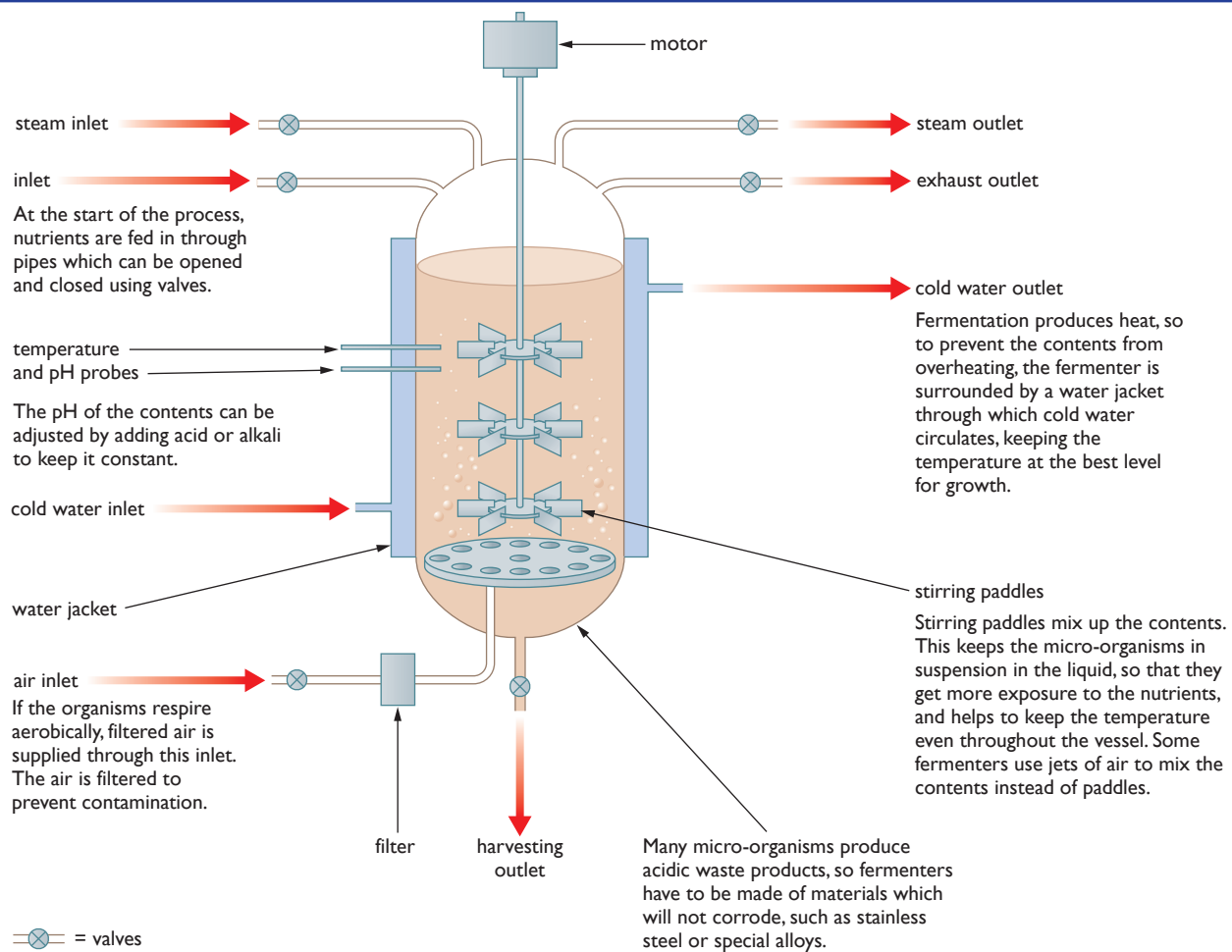
*Figure 1.17* Vinegar production

This type of production is called continuous production, as alcohol is continuously being fed in and ethanoic acid is continuously dripping out at the bottom of the fermenter.

**Producing antibiotics**

The first **antibiotics** all came from fungi. Today, they are increasingly being made using genetically modified bacteria in huge fermenters. The stages in the process are shown in figure 1.18 overleaf.





Genetically modified bacteria are also used to produce:

- insulin
- human growth hormone
- antibiotics
- enzymes for washing powders
- human vaccines, such as the vaccine against hepatitis B

*Figure 1.18 Production of antibiotics*

## Sewage treatment

All types of sewage treatment rely on the action of a range of micro-organisms to oxidise the organic matter present in sewage. There are two main methods:

- the percolating filter method
- the activated sludge method

### In the percolating filter method:

- sewage is screened to remove large pieces of debris
- it stands in a large settlement tank to allow suspended matter to settle out
- it is then allowed to trickle through a bed of stones, each of which is covered in a layer of micro-organisms (bacteria, fungi and protozoa)
- as the sewage trickles through the filter bed, the micro-organisms digest the organic matter and absorb the products
- by the time the liquid reaches the bottom of the filter bed, the polluting organic matter has all been removed

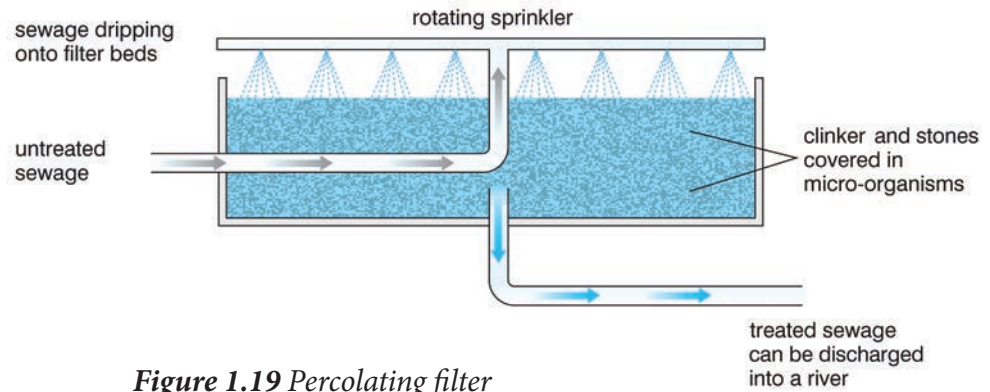


Figure 1.19 Percolating filter

**In the activated sludge method:**

- sewage is screened and allowed to stand in settlement tanks, as in the percolating filter method
- it is then pumped into treatment tanks, where:
  - activated sludge, rich in micro-organisms, is added
  - oxygen is blown through the mixture
- in the oxygenated mixture, the micro-organisms from the added activated sludge oxidise the polluting organic matter, reproducing as they do
- some of the sludge formed is recycled to ‘seed’ new tanks.

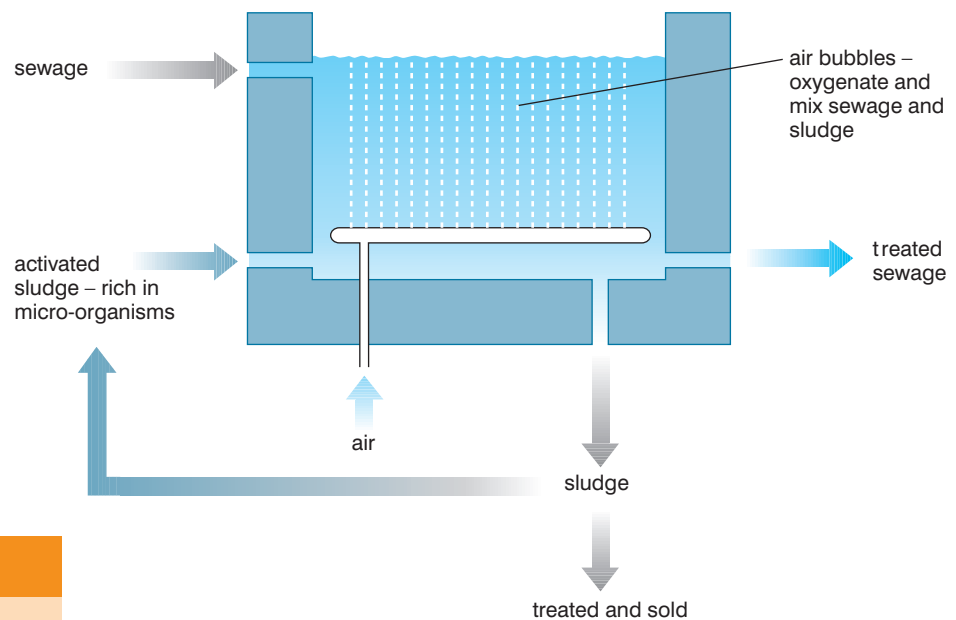


Figure 1.20 The activated sludge method

**Activity 1.9**

We use bacteria in many different ways in industry. Make a poster to show as many of these different industrial uses of bacteria as you can. Make your poster clear and colourful so people enjoy learning from it.

## How are bacteria genetically modified?

You have already been introduced to **genetic engineering**.

Genes are sections of the DNA of an organism that code for a particular protein. So if a gene can be transferred successfully from one organism into a bacterium, the genetically modified bacterium will now make the protein that its 'new gene' codes for.

The development of three main techniques made genetic engineering possible.

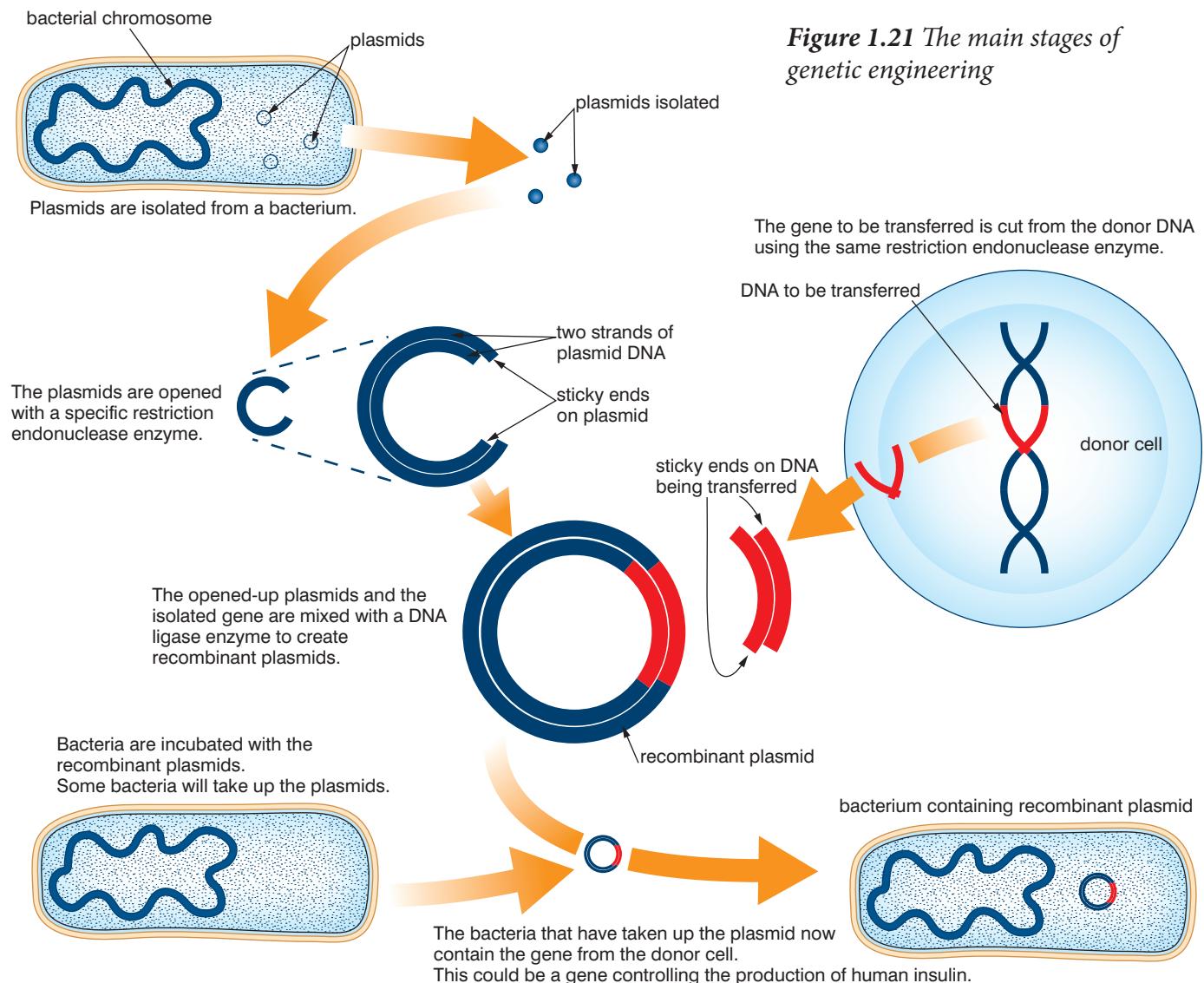
- The discovery that genes can be 'cut' out of a DNA molecule using enzymes called restriction endonucleases.
- The discovery that genes can be inserted ('tied') into another DNA molecule using a ligase enzyme.
- Genes can be transferred into other cells using **vectors**. These are usually either plasmids (small pieces of circular DNA found in bacteria), or viruses.

Once the gene has been inserted into the new bacterium, the bacterium becomes a genetically modified or transgenic organism.

### KEY WORDS

**genetic engineering** the practice of transferring genes from one organism to another organism (either belonging to the same species or belonging to a different species). This is done by taking DNA from the first organism and transferring it to the second organism. Genetic engineering has only been practised since 1980

**vector** a means of transferring something. In genetic engineering, viruses are used as vectors to transfer genetic information between different organisms

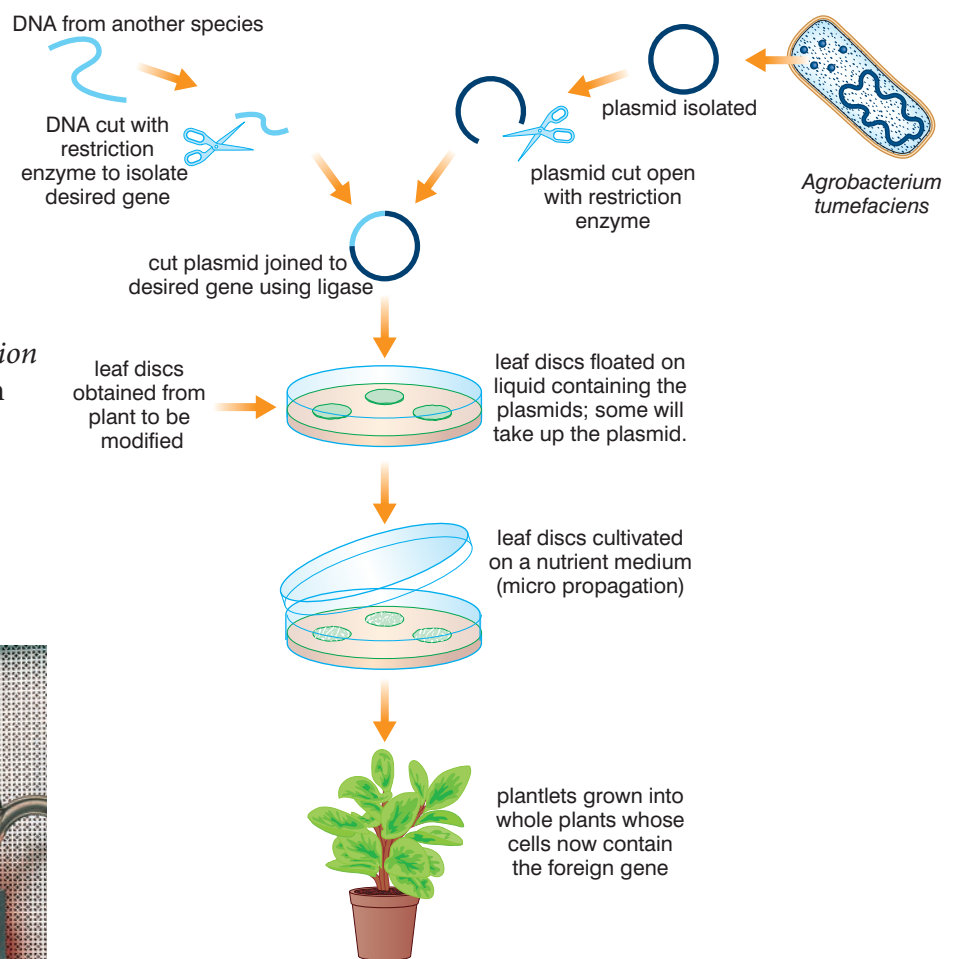


**Figure 1.21** The main stages of genetic engineering

Bacteria aren't the only organisms that have been genetically modified. Many crop plants have also had foreign genes inserted into them. These give the plants new properties, such as:

- resistance to infectious disease
- resistance to animal pests
- a longer shelf-life before decaying

Genetic engineering of plants posed problems for biologists, as plant cells will not accept plasmids in the same way as bacterial cells do. However, they discovered that one particular bacterium, called *Agrobacterium tumefaciens*, regularly infects plant cells. This bacterium can act as a vector to carry genes that have been inserted into a genetically modified *Agrobacterium* into plants. Figure 1.22 shows how this is done.



**Figure 1.22** Genetic modification of plants using *Agrobacterium*



**Figure 1.23** A scientist working with a gene gun

However, *Agrobacterium* can't be used to genetically modify all types of plant. It will not infect cereals such as maize, for example. To solve this problem, biologists developed the gene gun. This literally shoots the genes into cells of plants, using as 'bullets' tiny pellets of gold that are covered in DNA. You could think of it as the 'golden gun'.

The gene gun has made it possible to genetically modify plants such as maize, tobacco, carrots, soybean and apple. For example, maize has had genes inserted into it that cause it to:

- produce a pesticide that makes it resistant to some insect pests
- be resistant to some fungal diseases

## Review questions

Choose the correct answer from A to D.

- Sources of infectious organisms that spread to infect others are called:
  - hosts of infection
  - sources of infection
  - reservoirs of infection
  - sites of infection
- Disease-causing bacteria can be transmitted by:
  - sexual intercourse
  - droplet infection
  - eating contaminated food
  - all of the above
- Which of the following is *not* an infectious disease?
  - tuberculosis
  - AIDS
  - coronary heart disease
  - the common cold
- Which if the following statements are NOT true about nitrogen-fixing bacteria?
  - They are often found in nodules on the roots of legumes
  - They convert nitrogen gas into ammonium ions
  - They break down nitrate ions into ammonium ions
  - They play a vital role in the nitrogen cycle in nature
- In the sulphur cycle, the main source of sulphur for plants is:
  - sulphur in rocks
  - sulphates in the air
  - sulphur in water
  - sulphates in soil
- In the percolating filter method of sewage treatment:
  - the sewage is screened to remove large pieces of waste
  - the sewage trickles through stones covered in micro-organisms
  - the micro-organisms oxidise the organic matter in the sewage
  - all of the above
- DNA can be transferred into maize using:
  - plasmids
  - the gene gun
  - Agrobacterium*
  - viruses

8. In genetic engineering, a section of DNA is removed from a DNA molecule using:
  - A ligase enzymes
  - B plasmids
  - C restriction enzymes
  - D polymerase enzymes
9. Which of the following is NOT a term used to describe organisms that have had foreign genes added to them?
  - A transgenic organisms
  - B genetically modified organisms
  - C pathogenic organisms
  - D genetically engineered organisms
10. Which of the following were important in developing the germ theory of disease?
  - A Louis Pasteur, showing that excluding micro-organisms from wine prevented it from going sour
  - B Joseph Lister, showing that using carbolic acid, which killed bacteria, reduced infection during surgery
  - C Robert Koch, identifying specific micro-organisms associated with specific diseases
  - D all of the above

### 1.3 What are viruses?

By the end of this section you should be able to:

- Describe the structure of a virus, draw and label it.
- Explain the different forms of viruses and diagram them.
- Classify viruses and give examples of RNA, DNA, and retroviruses.
- Discuss the reproductive cycles of viruses and compare the lytic and lysogenic cycles of viral reproduction.
- Draw and label a bacteriophage.
- Compare viruses with free-living cells.
- Draw, label and describe the structure of HIV, show the structure of glycoprotein-120 on its surface and tell that it is this protein that allows HIV to bind with CD4 lymphocytes.
- Explain the life cycle of HIV, show how it replicates.

- Explain how different anti-retroviral drugs work and tell why HAART is more effective than single drug treatment.
- State the social and economic impacts of AIDS.
- Demonstrate the life skills that lead to responsible sexual behaviour.

**KEY WORD**

**virus** *some genetic material contained in a protein coat. It is not usually regarded as a living organism*

**Introducing viruses**

We have already looked a little at **viruses** and we have seen that there are reasons to consider them not to be living organisms – a virus particle (sometimes called a virion) is nothing like either a prokaryotic cell or a eukaryotic cell.

Viruses are much smaller than even the smallest bacterium. Most are between 0.01 and 0.1  $\mu\text{m}$  in length or diameter. This makes them at least 1000 times smaller than the smallest bacterium and 1 000 000 times smaller than most human cells.

The characteristics of viruses are shown in table 1.5.

*Table 1.5 Characteristics of viruses*

Feature	Virion (virus particle)
Size	0.01–0.1 $\mu\text{m}$
Nucleus	Absent
DNA	Tiny amount of linear DNA in some; others contain RNA but no chromosomes
Other cell organelles	Absent

Because they do not have the major organelles that are present in living cells, virus particles can't carry out any of the normal metabolic processes of cells, such as:

- respiration
- protein synthesis
- DNA replication
- photosynthesis
- active transport
- facilitated diffusion
- any other process requiring control by enzymes or the presence of proteins

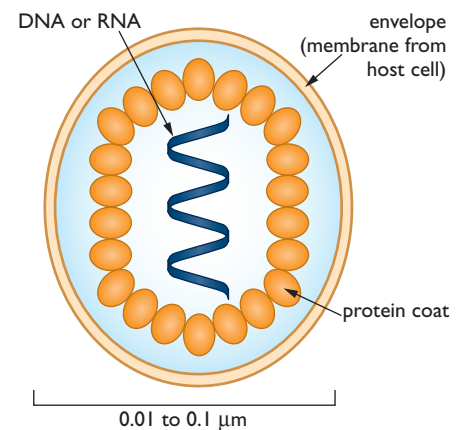
**DID YOU KNOW?**

The particle of a virus is called a virion. All virions contain at least two components:

- a protein shell or capsid
- DNA or RNA as the genetic material

Some also have:

- a membrane made from lipids and proteins outside the capsid
- other proteins and enzymes inside the capsid



**Figure 1.24** *The structure of a typical virus*

As a result, all viruses are parasites. The only way they can reproduce is to invade cells, 'hijack' the normal metabolic processes of those cells, and make the cells produce more virus. Once produced, the viruses escape from the cell and infect other cells. Figure 1.25 shows how this happens in two different types of viruses. Other viruses adopt different strategies.

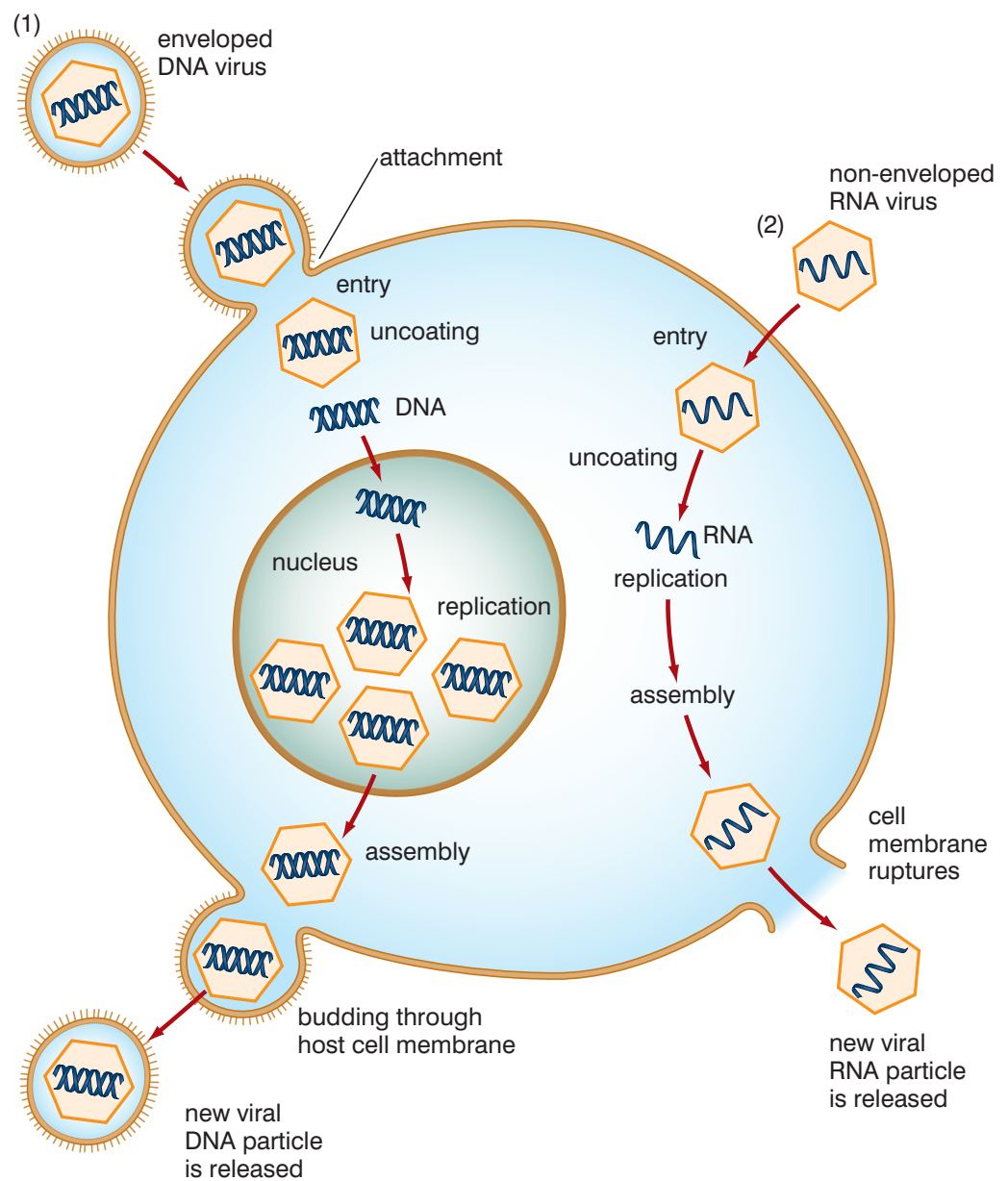


Figure 1.25 Stages of virus infection of cells.



## Classifying viruses

It is difficult to classify viruses because, even though they have a basic structure, there is a great deal of variation in their shape and the way in which they infect cells. However, they can be classified into three main groups, based on the nature of their genetic material and the way in which it is expressed. These groups are:

- **DNA viruses** – for example, Herpes simplex (causes cold sores)
- **RNA viruses** – for example, H1N1 virus (causes swine flu)
- **retroviruses** – for example, HIV (causes AIDS)

### DNA viruses

When a DNA virus infects a cell, the viral DNA can replicate itself and can also control the synthesis of virus proteins, so that the new DNA and new protein can be assembled into new virus particles.

### RNA viruses

When an RNA virus infects a cell, its RNA can be used to synthesise more viral proteins, including an enzyme that controls the synthesis of more RNA. The new RNA and new proteins can be assembled into new virus particles.

With the exception of the RNA viruses, all organisms store their permanent information in DNA, using RNA only as a temporary messenger for information. DNA is quite a stable molecule, is not very reactive with other molecules, and replicates very accurately. In contrast, RNA is quite unstable and makes frequent mistakes during copying.

But these very properties make RNA ideal for the storage of viral information. Once the host's immune system has learned to recognise an infecting virus and create antibodies against it, it can quickly destroy it, and the virus needs to change its nature so that the host's immune system will no longer recognise it – it must mutate. The unstable nature of RNA allows RNA viruses to evolve far more rapidly than DNA viruses, frequently changing their surface structure.

### Retroviruses

Retroviruses also contain RNA, but replicate in a different way. When they infect cells, they release into the cells their RNA and an enzyme that causes it to be 'reverse-transcribed' into DNA. This then controls the formation of more viral protein and RNA that can be assembled into new virus particles.

Viruses can also be classified by the type of organism they infect:

- animal-infecting viruses
- plant-infecting viruses
- bacteria-infecting viruses – these are called **bacteriophages**

Bacteriophages have a really unusual shape – they look rather like a lunar landing module!

## KEY WORDS

**DNA virus** contains genetic information stored in the form of DNA

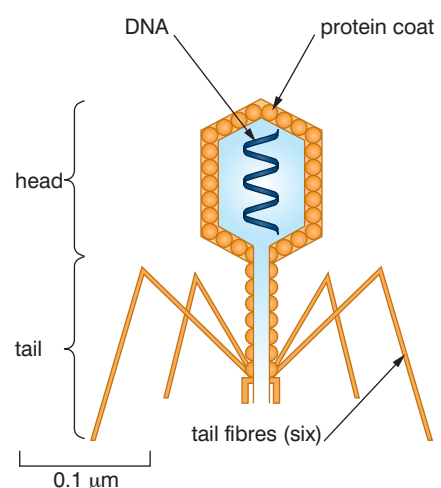
**RNA virus** contains genetic information stored in the form of RNA

**retrovirus** an RNA virus that converts its genetic information from RNA into DNA after it has infected a host

**bacteriophage** a virus that uses a bacteria to replicate its genetic information

## DID YOU KNOW?

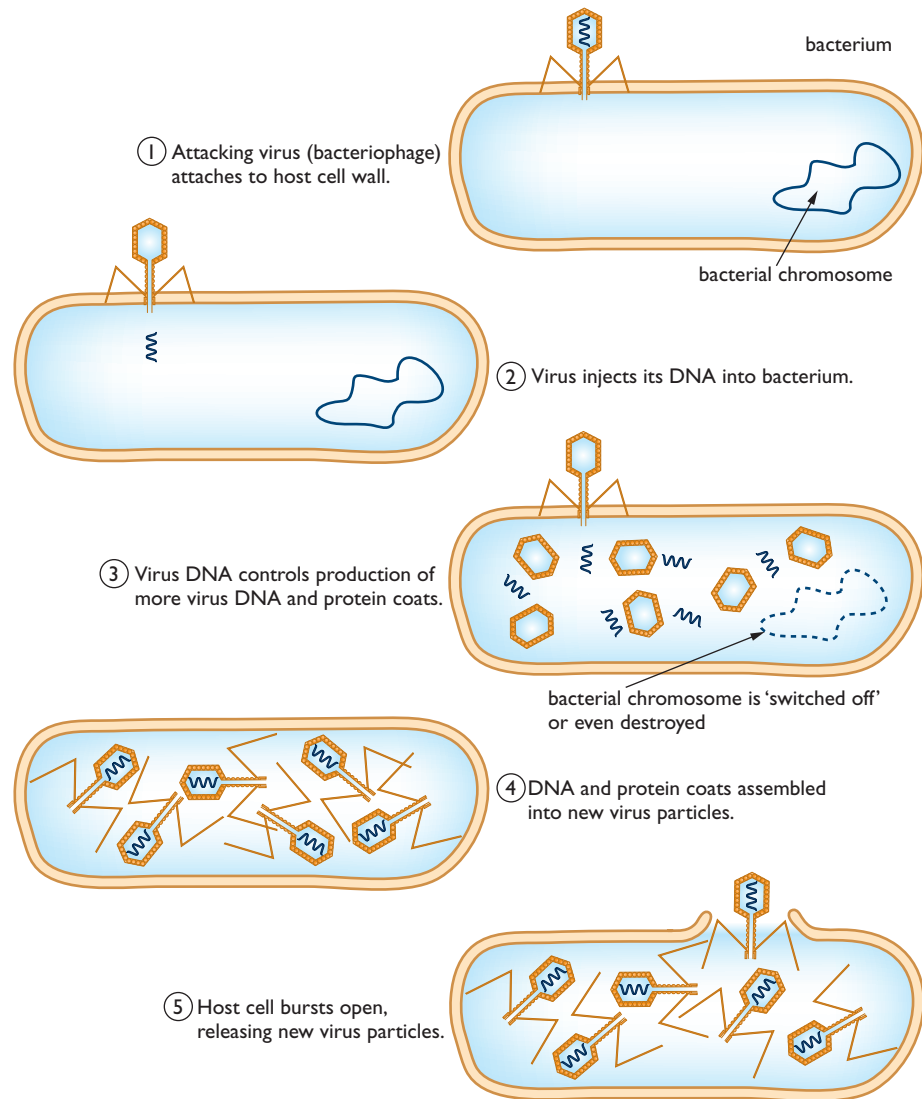
We say that the RNA is reverse-transcribed because, in cells, DNA is normally transcribed into RNA as part of the process of protein synthesis. Carrying out the process in the opposite direction is reverse transcription.



**Figure 1.26** Structure of a bacteriophage

### Virus multiplication

Much of our knowledge about how viruses are reproduced comes from work on bacteriophages. One bacteriophage in particular, called T4, has been studied more than any other. Its reproductive cycle is shown in figure 1.27.



**Figure 1.27** The reproductive cycle of bacteriophage T4

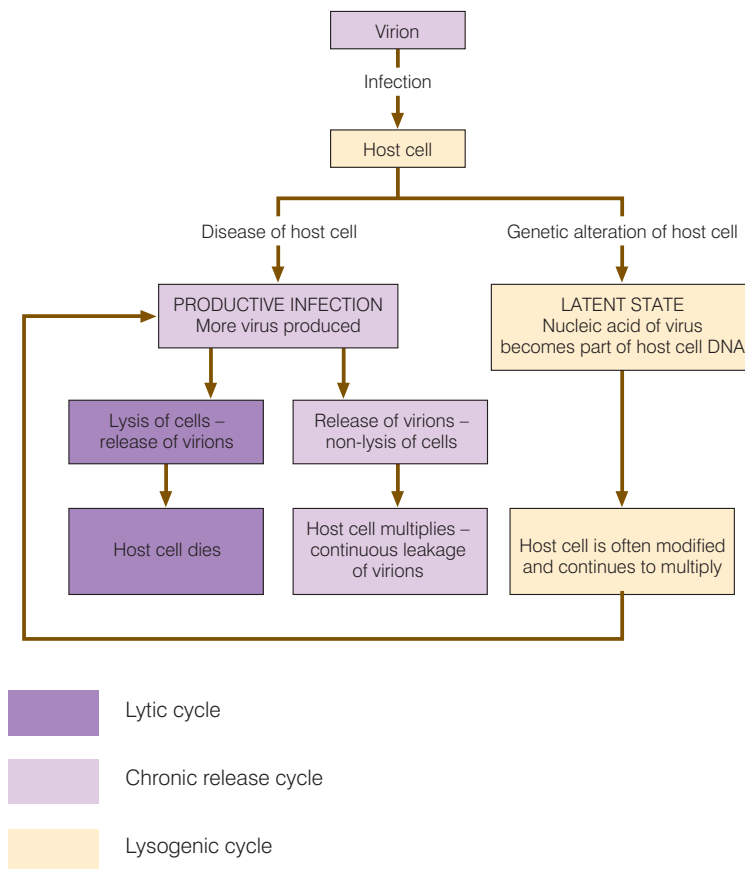
This type of life cycle is called a **lytic cycle** because it causes the rupture (lysis) of the host cell.

From research on bacteriophages, we know that this is not the only type of reproductive cycle in viruses. Sometimes, instead of causing the cell to burst and release the viruses all at once, a few at a time are released by exocytosis through the plasma membrane. This type of life cycle is called a **chronic release cycle**, because release of new viruses is ongoing (chronic).

In other cycles, the virus's DNA becomes incorporated into the DNA of the host cell. Each time the cell divides, the DNA is replicated, and each daughter cell gets a copy of the cell's DNA, which now includes the virus DNA. This can continue for many generations until some factor in the environment triggers the

virus DNA to start producing virus proteins. Then whole viruses are assembled, which then leave the cell either by causing cell lysis (splitting), or by chronic (ongoing) exocytosis from the plasma membrane. This type of life cycle is called a **lysogenic cycle**.

These different reproductive strategies are summarised in figure 1.28.



**Activity 1.10**

You have now studied viruses and bacteria as well as plant and animal cells. Brainstorm the similarities and differences between them and then produce a large, clear table comparing viruses, bacteria, plants and animals.

**Figure 1.28** Reproductive strategies of viruses: lytic cycle, chronic release cycle and lysogenic cycle

**Modes of virus transmission**

As well as having different reproductive strategies inside the host cell, different viruses also enter cells in different ways.

- The bacteriophage injects just its DNA; the rest of the virus remains outside the cell.
- Many (but not all) animal viruses manage to get the whole virus inside the cell. This is done by tricking the cell into bringing the virus into the cell in the same way as it would with any large protein molecule – using the process of endocytosis.

HIV and AIDS

What is HIV like?

Human Immunodeficiency Virus or **HIV** is one of the retroviruses. It has RNA as its genetic material. This is transcribed to DNA by the enzyme reverse transcriptase, which HIV contains together with the RNA.

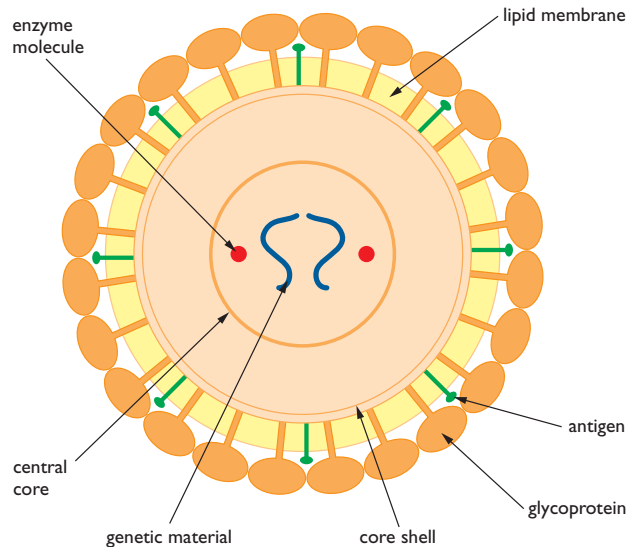


Figure 1.29 The structure of HIV

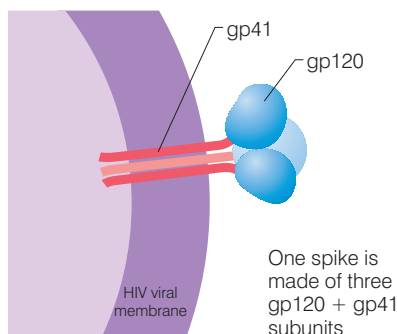


Figure 1.30 The spikes on the surface of HIV are made from three gp120 glycoprotein molecules attached to another molecule called gp41. The shape of these spikes allows them to bind with CD4 receptors on the T-helper cells. Because they have this particular receptor on their surface, they are called CD4 lymphocytes.

HIV targets cells that form part of the immune system. Its main target is a type of cell called a CD4 T-lymphocyte. These cells are also called T-helper cells, because they ‘help’ other cells in the immune system to mount an immune response to pathogens in the body. Without this response, pathogenic micro-organisms can multiply in the body and cause disease.

HIV has spikes on its surface, the heads of which are made from the glycoprotein known as gp120. This binds with CD4, a protein that protrudes from various types of human cell. A gp120 sticking out of an HIV virus particle connects with a CD4 sticking out of a cell like an egg fitting into an egg cup. Once the virus has attached to a cell, it can go on to the next stage and merge with the host cell.

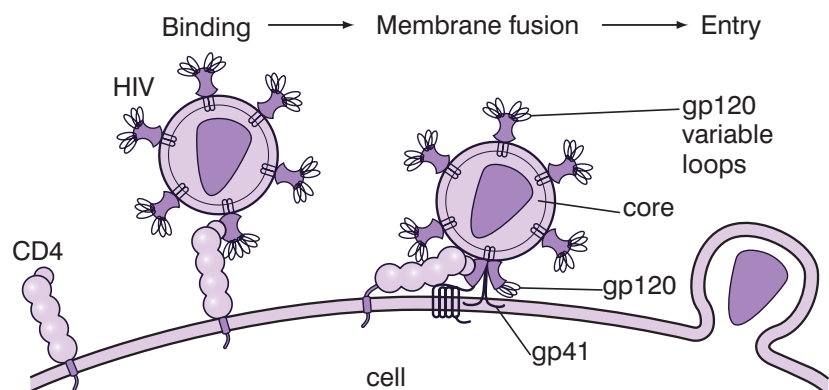


Figure 1.31 HIV infection of CD4

Besides the T-helper cells, there are other types of cell that carry CD4 on their surface – such as **macrophages** and some natural killer cells. T-helper cells are the most important, though, because they are co-ordinators of the immune system. If their activity is impaired, it can have serious effects on the body's response to infections by other organisms.

### How does HIV reproduce and cause AIDS?

After HIV has bound to the CD4 receptors on the surface of the T-helper cell, the following events occur:

1. It fuses with the plasma membrane and then releases its RNA and reverse transcriptase enzyme into the cell.
2. The reverse transcriptase converts the RNA into DNA using building blocks called nucleotides, which are provided by the cell.
3. The viral DNA becomes incorporated into the cell's own DNA.
4. The viral DNA is transcribed to viral RNA, which starts producing viral proteins, including the enzyme reverse transcriptase.
5. The RNA, proteins and reverse transcriptase molecules are assembled by the cell into new HIV particles that escape by 'budding' from the cell membrane – this is an example of chronic release.
6. The viruses then infect other T-helper cells.

Some HIV proteins remain on the surface of the infected CD4 cell and are recognised by the immune system – these cells are destroyed. The cycle of infection, reproduction and destruction of infected cells repeats itself for as long as the body can keep replacing the CD4 lymphocytes.

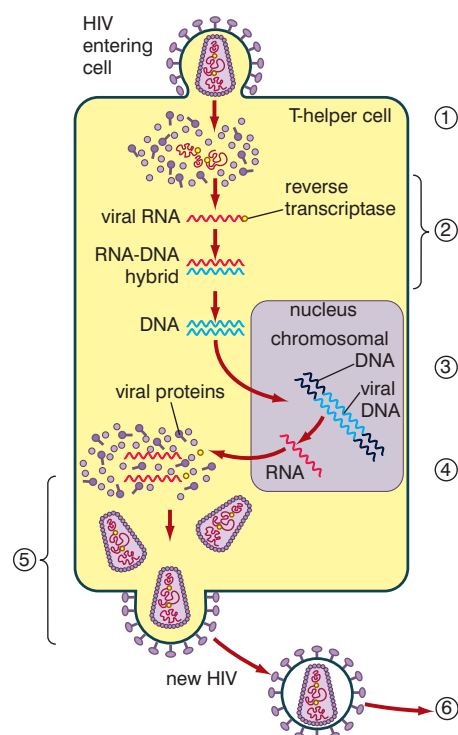


Figure 1.32 The reproductive cycle of HIV.

### KEY WORDS

**HIV** HIV (human immunodeficiency virus) is the virus now known to cause AIDS

**AIDS** (acquired immune deficiency syndrome) is a disease that causes its victim's immune system to degenerate leaving them vulnerable to infectious diseases and some types of tumour

**macrophage** (also called a white blood cell) is a cell that surrounds and destroys pathogens

### Activity 1.11

It is important for people to know as much as possible about HIV/AIDS, including how to prevent the virus spreading and how to support those affected by the virus. Plan an HIV/AIDS awareness campaign to be used in your community.

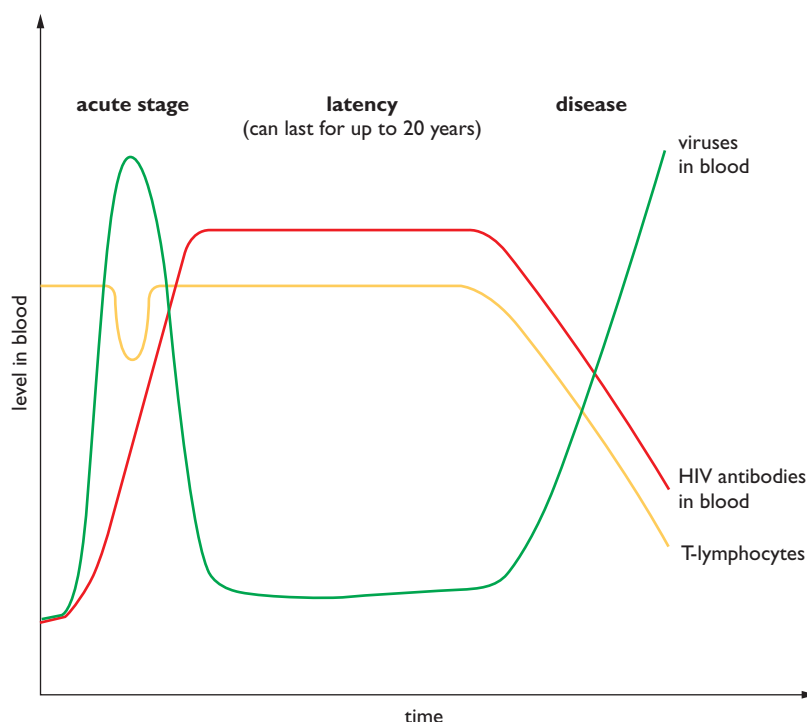
Eventually, the body will not be able to replace these cells, and the number of free viruses in the blood will increase dramatically – HIV may infect other areas of the body, including the brain.

Because of the drastic reduction in the number of T-helper cells, the immune function is severely reduced and many opportunistic infections may occur (including pneumonia and tuberculosis), together with rare cancers like Kaposi’s sarcoma.

Figure 1.33 summarises these changes.

**DID YOU KNOW?**

As well as infected cells being destroyed by natural killer cells, other lymphocytes make antibodies that target any free HIV in the blood. The presence of these antibodies can be detected, and the person is diagnosed as being HIV-positive.



**Figure 1.33** Changes in blood caused by HIV infection over time

The period when the body keeps replacing the CD4 lymphocytes as fast as they are destroyed is called the **latency period** and can last for many years.

**Can AIDS be treated?**

Although there is no cure for AIDS and, as yet, no vaccine to give immunity against infection, there are a number of drugs – called anti-retroviral drugs – that can be effective in slowing down the progression to AIDS. These drugs work by blocking the reproduction of the virus in the CD4 lymphocytes. There are several different drugs that act in different ways at different stages of the cycle of reproduction.

Because the drugs act on different stages of the HIV life cycle, the most effective treatment is obtained when they are used together. This is called **High Activity Anti-Retroviral Treatment (HAART)**. Although it is effective against HIV, it does have unpleasant side-effects.

**Activity 1.12: Avoiding AIDS**

Avoiding AIDS is about respect

- You respect your body – you refuse to expose it to HIV
- You respect your future – you refrain from sexual intercourse or always use condoms correctly

Work in pairs and think of five more ‘respects’ that will help a person to avoid AIDS. For each write a short paragraph explaining how respecting each item will help you to avoid AIDS and incorporate the paragraphs into a poster.

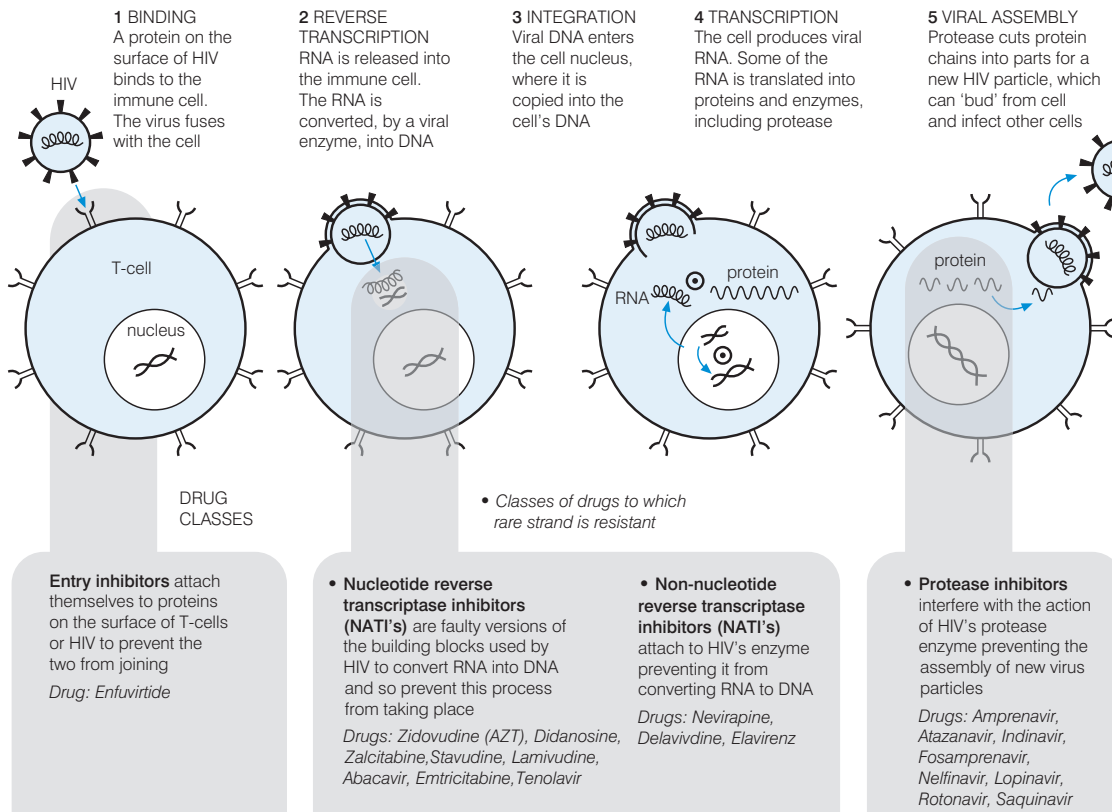


Figure 1.34 The effects of different anti-retroviral drugs

## What is the social and economic impact of AIDS?

Within families, the infection of family members is often not a subject for discussion. This is because of:

- shame associated with admitting to being infected (which is connected with the taboo on speaking about sexuality)
- fear of being isolated (or putting the family under pressure)
- fear of losing a job, etc.

In many cases, infected individuals have to deal with their infection alone. This puts immense emotional pressure on them. For a growing number of infected people, suicide is a way out of this situation. Traditional coping strategies and the extended family can no longer manage the situation.

Many affected families find themselves in a vicious circle:

- an increasing amount of money is needed for medical treatment and burials, but
- the number of breadwinners is decreasing.

The need to deal with the increasing number of orphans leads to more children dropping out of school to work in the household or in agriculture.

Nationally, AIDS has a serious economic impact in two main areas:

- labour supply – the loss of young adults in their most productive years will affect overall economic output

## A VACCINE FOR AIDS?

Despite nearly 100 clinical trials there is no effective AIDS vaccine. Why not?

- the virus mutates (changes) regularly and so a vaccine against one strain would be ineffective against a new strain
- it infects the immune system itself
- live attenuated (harmless) virus particles cannot be used because of the danger they will re-acquire their virulence
- AIDS is a retrovirus and once RNA is converted to DNA, it can remain hidden in the host cell DNA for many years
- the only effective vaccine is likely to be one that prevents the initial infection by HIV; this is very difficult to achieve

- costs:
  - direct costs including expenditure for medical care, drugs and funeral expenses
  - indirect costs including lost time due to illness, recruitment and training costs to replace workers, and for care of orphans
  - if costs are financed out of savings, then the reduction in investment could lead to a significant reduction in economic growth

The spread of AIDS can be limited by:

- responsible sexual behaviour
  - limiting the number of sexual partners
  - using condoms
- male circumcision (this reduces the risk of males acquiring the disease)

### Activity 1.13: The agree/disagree game

#### Activity

1. Your teacher will place signs reading AGREE, DISAGREE and DO NOT KNOW around the room.
2. Your teacher will then read aloud a statement from the list below to the class.
3. You should respond to the statement by standing next to the sign that best represents your opinion about the statement.
4. The people by each sign should explain why they agree, disagree, or don't know.

#### Statements

- There are more serious health problems than AIDS such as malaria and malnutrition.
- All people with HIV should be forced to carry an identity card.
- People with HIV/AIDS can contribute much to society.
- People at risk of HIV infection should be made to take a test.
- People with HIV and AIDS should be isolated.
- If you stick to one partner, you will not become infected by HIV.
- All people suffering from AIDS should be cared for in a hospital.
- I would feel embarrassed talking about condoms.
- It is natural for young men to experiment with several sexual partners.
- The main reason to have sex is for pleasure.
- AIDS is a punishment from God.
- We all die sometime, so if I die from AIDS, that's just how I'll go.
- I am not the kind of person to get HIV/AIDS.
- Condoms prevent you from getting HIV.



**Activity 1.14: A case study**

Read the following case study.

Almaz is seventeen and has only ever had one boyfriend who she wants to marry. She told him that she wants to wait until they get married before having sex. Her boyfriend's friends teased him for still being a virgin and so he found another girlfriend in a different township who will have sex with him. He says he uses condoms with the other girlfriend because he does not want her to get pregnant.

Imagine you could hear Almaz talking to her boyfriend about the situation. What do you think each might say to the other? Write a short dialogue between them, making it clear who is saying what.

You could start it in the following way:

Almaz: So you have a new girlfriend who has sex with you?

Boyfriend: Yes, but I always use a condom, and you know it's you I really want to be with.

Almaz: Do I?

Boyfriend: You must do, I only left because ...

Almaz: I wouldn't have sex with you – is that right?

Things you could consider are:

- What does Almaz feel about the situation?
- Does she still believe her decision to wait until she is married to have sex is the right one? (Why or why not?)
- What might her boyfriend say about being teased about being a virgin? What could Almaz do about this?
- Were the boys who were doing the teasing also virgins?
- If Almaz would decide to have sex with her boyfriend, how can she know that he *has* used condoms with the other girlfriend?

**Review questions**

Choose the correct answer from A to D.

1. Compared with bacterial cells, viruses are:
  - A smaller, with more organelles
  - B smaller, with fewer organelles
  - C larger, with fewer organelles
  - D larger, with more organelles
2. When bacteriophages infect bacteria:
  - A they inject only the DNA
  - B the whole virus enters by exocytosis
  - C the DNA enters by endocytosis
  - D none of the above
3. In the lysogenic cycle of virus reproduction:
  - A the viral DNA becomes incorporated into the host cell's DNA
  - B when the host cell divides, copies of the viral DNA are passed to the daughter cells
  - C eventually the viral DNA becomes activated and causes the production of viral proteins
  - D all of the above

**Activity 1.15: Debate**

Some people believe that viruses are not living organisms at all. Others believe that they are highly specialised microorganisms. In this activity you will debate this issue.

Your teacher will divide the class into three groups:

- Group 1 – this group will present arguments to support the idea that viruses are not living organisms
- Group 2 – this group will present arguments to support the idea that viruses are highly specialised microorganisms
- Group 3 – this group will form the ‘audience’ who will:
  - question the members of each of the other groups after their presentation
  - vote to decide the outcome of the debate

The debate will follow the following procedure:

- Group 1 will present their case (2 minutes)
- Group 2 will present their case (2 minutes)
- Groups 1 and 2 can question the other group and try to disprove their ideas (2 minutes)
- Group 3 (the audience) can question any members of any group (4 minutes)
- Group 3 votes on the issue

4. Some biologists do not think viruses are living organisms because:
  - A they reproduce inside the cells of other living organisms
  - B they contain genetic material
  - C the only function of living organisms that they carry out is reproduction
  - D they are parasites
5. It is true to say that:
  - A all viruses are parasites
  - B all viruses contain DNA
  - C all viruses contain RNA
  - D all viruses have a lysogenic reproductive cycle
6. HIV is:
  - A a retrovirus
  - B an RNA virus
  - C a DNA virus
  - D a bacterium
7. gp120 is:
  - A a glycoprotein on the surface of HIV
  - B a glycoprotein on the surface of T-helper cells
  - C a lipoprotein on the surface of HIV
  - D a lipoprotein on the surface of T-helper cells
8. The period in the development of AIDS when the body replaces T-helper cells as fast as they are destroyed is called:
  - A the acute phase
  - B the binding and fusion phase
  - C the latency phase
  - D the escape phase
9. Being HIV-positive means that:
  - A a person has AIDS
  - B a person has been in contact with HIV
  - C a person has other diseases as a result of HIV
  - D a person has HIV antibodies in his or her blood
10. Which of the following is NOT a way in which AIDS can affect families?
  - A it can increase the medical costs
  - B it can reduce the family income
  - C it can help people to find work
  - D it can cause sadness and bereavement

## Summary

In this unit you have learnt that:

- The five different groups of micro-organisms are:

Group	Comments	Example
Protozoa	Eukaryotic cells, unicellular, lack cell wall	<i>Amoeba</i> , <i>Plasmodium</i>
Fungi	Eukaryotic cells, non-cellulose cell wall Only yeasts are unicellular Most have hyphae which form a mycelium	<i>Yeast</i> , <i>Candida</i> <i>Mucor</i> , <i>Penicillium</i>
Algae	Eukaryotic cells, non-cellulose cell wall Unicellular algae are part of the plankton	<i>Chlamydomonas</i>
Bacteria	Prokaryotic cells, non-cellulose cell wall, all unicellular	<i>Streptococcus</i> , <i>Lactobacillus</i>
Viruses	Acellular, made only of nucleic acid and protein coat	HIV, influenza virus

- Eukaryotic and prokaryotic cells differ in a number of ways:

Feature	Prokaryotic cell	Eukaryotic cell
Size	1 $\mu\text{m}$ to 10 $\mu\text{m}$	10 $\mu\text{m}$ to 100 $\mu\text{m}$
Nucleus present	No	Yes
DNA	In a continuous loop, no chromosomes	Linear DNA in chromosomes
Mitochondria	Absent (but all can still respire)	Present
Chloroplasts	Absent (but some can photosynthesise)	Present in some
Ribosomes	Small (70S)	Large (80S)

- The main shapes of bacterial cells are cocci (spheres), bacilli (rods) and spirochaetes (spirals).
- Bacteria can be classified as Gram-positive or Gram-negative by their response to the Gram stain.
- Micro-organisms cause disease in different ways:
  - bacteria release toxins that affect cells as they multiply
  - viruses enter cells and take over the 'metabolic machinery' of these cells
  - fungi secrete enzymes that digest substances in the tissues where they grow
  - protozoa have no set pattern of causing disease
- The main methods of transmission of disease are:
  - droplet infection
  - drinking contaminated water and eating contaminated food
  - direct contact
  - sexual intercourse
  - blood-to-blood contact
  - animal vectors

- Diseases can be categorised into:
  - infectious diseases (caused by the entry of some organism into the body)
  - human-induced diseases (caused by lifestyle/working conditions, for example, heart disease)
  - degenerative diseases (often the result of ageing – for example, arthritis)
  - genetic diseases (mutant alleles sometimes cause a large malfunction, for example, haemophilia)
  - deficiency diseases (caused by lack of specific nutrients – for example, scurvy)
  - social diseases (result from social activities, for example, alcoholism)
- Bacteria are involved in cycling minerals through ecosystems; these include carbon, nitrogen and sulphur.
- Bacteria have been used to manufacture bread, alcohol, irgo/yoghurt and vinegar. They are also used in the production of antibiotics, sewage treatment and water purification as well as many other key processes.
- Bacteria can be genetically modified by transferring a gene from another organism; the newly formed transgenic bacterium is then able to carry out the process specified by its new gene.
- Viruses are different from other micro-organisms because they have no cellular organelles and so cannot carry out any metabolic processes; they must all enter other cells to reproduce.
- Viruses can be classified into DNA viruses, RNA viruses and retroviruses.
- There are three different life cycles in viruses:
  - lytic life cycle (infection causes the host cell to burst and release new viruses)
  - lysogenic life cycle (infection causes the virus to enter a latent state where its DNA is reproduced with the host DNA, but no new viruses are formed)
  - chronic release life cycle (infection causes viruses to be released without killing the host cell)
- AIDS (Acquired Immune Deficiency Syndrome) is caused by HIV (Human Immunodeficiency Virus).
- The glycoprotein gp120 on HIV binds with the CD4 receptor on T-helper cells.
- AIDS reduces the body's immune response by reducing the number of T-helper cells; this can take a long time. When the body is replacing the helper cells as fast as they are destroyed, the person is said to be in the latency phase of infection.
- AIDS is often best treated by HAART (High Activity Anti-Retroviral Therapy) in which several anti-retroviral drugs are combined to target different stages of the HIV infection process.
- The spread of AIDS can be limited by responsible sexual behaviour, including the use of condoms and restricting the number of sexual partners.

### End of unit questions

1. Name four different types of micro-organism. Give an example of each type you name.
2. Describe four ways in which a bacterial cell is different from:
  - a) an animal cell
  - b) a virus
3. A student carried out an experiment to try to repeat the work of Louis Pasteur. She used the apparatus shown in figure 1.35.

She used a broth containing all the nutrients needed by micro-organisms in test tubes.

She heated all the test tubes at 121°C for 20 minutes. She left them for a few days, then looked to see if the broth in any of the tubes had turned cloudy. This would have meant that micro-organisms were present.

- a) Why did she heat all the tubes to 121°C at the start of the experiment?
- b) Predict the results she would have found in each tube. Explain the reasoning behind your answers.

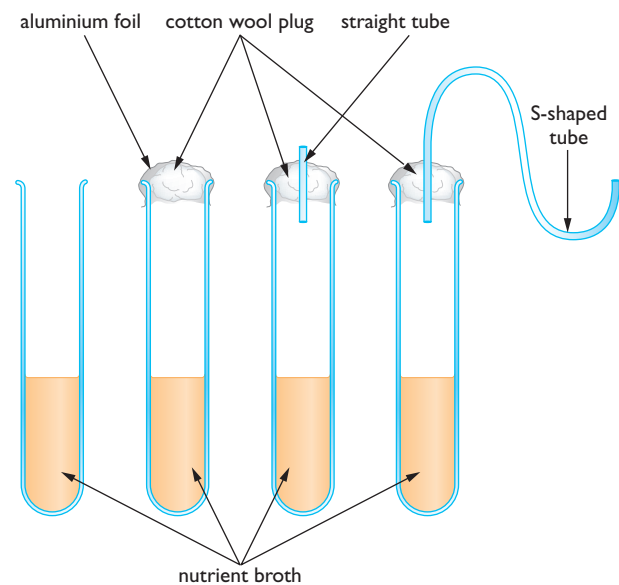


Figure 1.35

4. Figure 1.36 shows the main stages in transferring the gene for insulin production from a human cell to a bacterium.

- a) Name the enzyme used to:
  - i) cut the gene from the DNA in the human cell
  - ii) 'stitch' the gene into the plasmid
- b) What is the importance of the plasmid in this process?
- c) Why cannot plants be genetically engineered in this way?
- d) Describe *two* methods used to genetically modify plants.

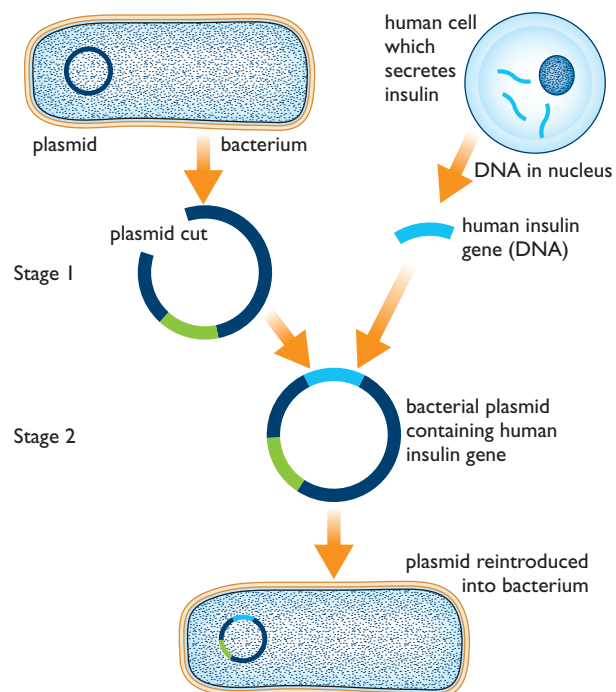


Figure 1.36

5. AIDS is caused by the Human Immunodeficiency Virus (HIV)
  - a) Describe three ways in which HIV can be transmitted from one person to another.
  - b) What is the 'latency' phase of AIDS?
  - c) Describe *two* ways in which anti-retroviral drugs reduce the spread of HIV within a person.
6. Figure 1.37 shows the main stages of the nitrogen cycle.

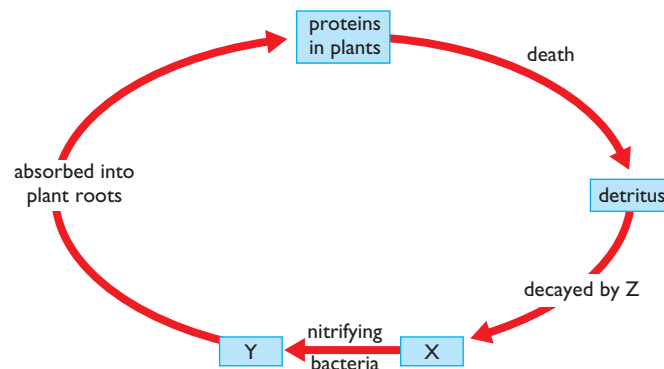
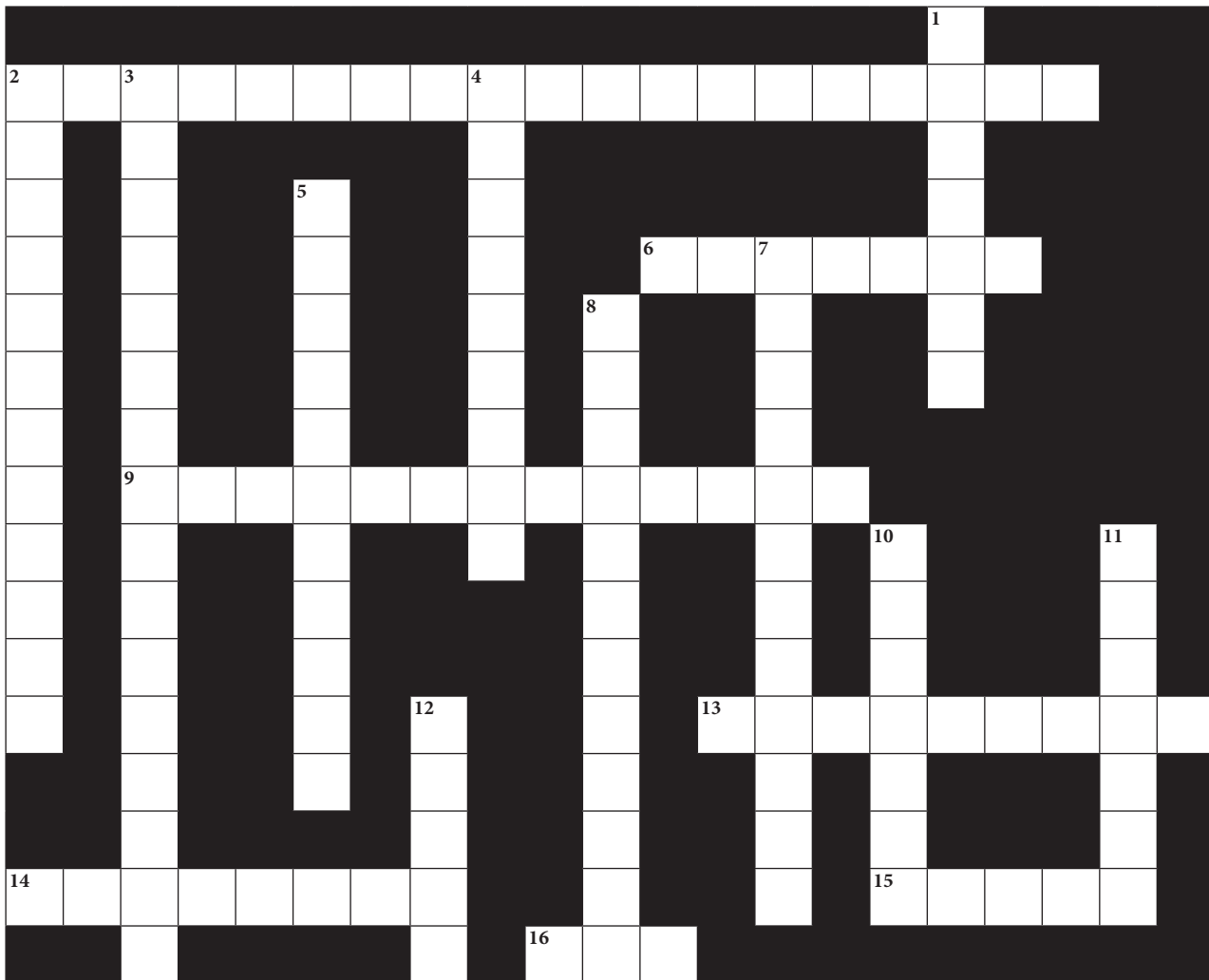


Figure 1.37

- a) What types of organism are represented by Z?
  - b) What mineral ions are represented by Y and X?
  - c) What are:
    - i) nitrogen-fixing bacteria?
    - ii) denitrifying bacteria?
7. Write an essay about the impact of AIDS. You should include the following ideas in your essay:
    - how AIDS affects families
    - how AIDS affects the country as a whole
    - the life skills that people need to cope with AIDS themselves or to care for people with AIDS
    - the life skills people need to adopt responsible sexual behaviour

Copy the crossword puzzle below into your exercise book (or your teacher may give you a photocopy) and solve the numbered clues to complete it.



**Across**

- 2. The bacteria that are used to produce antibiotics have had other genes put into them; they have been ... (11, 8)
- 6. A condition with a specific cause in which part or all of a body is made to function in a non-normal and less efficient manner (7)
- 9. A process in the nitrogen cycle in which ammonium is converted into nitrate (13)
- 13. A source of disease-causing micro-organisms is a ... of infection (9)
- 14. Unicellular organisms with no cell wall (8)
- 15. Spherical bacteria (5)
- 16. Gp120 molecules on HIV bind with this type of receptor on T-helper cells (3)

**Down**

- 1. Acellular micro-organisms (7)
- 2. Bacteria that stain purple with Gram's stain (4-8)
- 3. A process in the nitrogen cycle in which nitrogen gas is converted to ammonium (8, 8)
- 4. A type of viral life cycle in which, for a period, the infected cell keeps reproducing, copying the viral DNA without producing more viruses (9)
- 5. Bacteria have this type of cell (11)
- 7. Spiral or corkscrew-shaped bacteria (12)
- 8. Diseases caused by a person's lifestyle or working conditions are ... (5, 7)
- 10. Diseases that are inherited are ... diseases (7)
- 11. Rod-shaped bacteria (7)
- 12. Unicells of this group make up much of the plankton (5)

Contents	
Section	Learning competencies
2.1 Cycling matter through ecosystems (page 45)	<ul style="list-style-type: none"> <li>• Explain the need for the recycling of materials through ecosystems.</li> <li>• Illustrate the nutrient cycle.</li> <li>• Describe and diagram the water, carbon, nitrogen, sulphur and phosphorus cycles.</li> <li>• State that materials do not always remain within an ecosystem.</li> </ul>
2.2 Ecological succession (page 54)	<ul style="list-style-type: none"> <li>• Explain what is meant by the term succession.</li> <li>• Describe the natural process by which bare land turns out to be productive by succession.</li> <li>• Describe primary and secondary succession.</li> <li>• Give examples of primary and secondary successions.</li> </ul>
2.3 Biomes (page 58)	<ul style="list-style-type: none"> <li>• Define the term biome.</li> <li>• Name the major terrestrial and aquatic biomes.</li> <li>• Describe the main features of each biome.</li> <li>• Give examples of the flora and fauna of each biome.</li> <li>• Appreciate the duty of care we have for the flora and fauna of the biomes.</li> </ul>
2.4 Biodiversity (page 63)	<ul style="list-style-type: none"> <li>• Explain what is meant by the term biodiversity.</li> <li>• Appreciate the significance of biodiversity, both globally and locally.</li> <li>• Explain how biodiversity is threatened in many areas of the world.</li> <li>• Explain the status of biodiversity in Ethiopia.</li> <li>• Describe the principles of conservation.</li> <li>• Reflect a concern towards biodiversity and the need for its conservation.</li> <li>• Appreciate the interdependence of plant and animal biodiversity.</li> <li>• Engage in a tree-growing project.</li> <li>• Express willingness to participate in tree-growing activities in your locality.</li> </ul>



## Contents

Section	Learning competencies
2.5 Populations (page 80)	<ul style="list-style-type: none"> <li>• Compare and contrast arithmetic and exponential growth.</li> <li>• Compare intra-specific and inter-specific competition.</li> <li>• Describe and explain the factors that influence the rate of population growth, including natality (birth rate) and mortality (death rate).</li> <li>• Interpret a population growth rate curve.</li> <li>• Define the term carrying capacity and appreciate the importance of the concept.</li> <li>• Describe and explain the impact of rapid population growth on development.</li> <li>• Describe measures that could and should be undertaken to control population growth.</li> </ul>

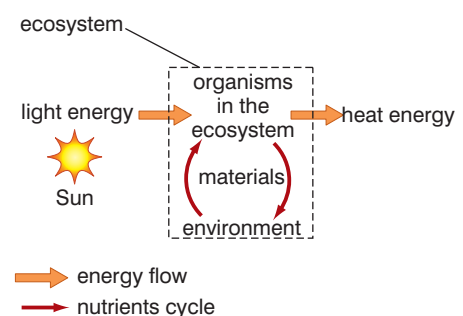
## 2.1 Cycling matter through ecosystems

By the end of this section you should be able to:

- Explain the need for the recycling of materials through ecosystems.
- Illustrate the nutrient cycle.
- Describe and diagram the water, carbon, nitrogen, sulphur and phosphorus cycles.
- State that materials do not always remain within an ecosystem.

### Why is it important that materials are recycled?

We have studied the flow of energy through ecosystems and seen how energy is continually lost as heat from the ecosystem and has to be replaced as light. Nutrients, however, are recycled. Figure 2.1 illustrates this difference.



**Figure 2.1** The recycling of nutrients in an ecosystem.

**Did you ever consider ... just how second-hand our bodies are?**

Have you ever thought that some of the carbon atoms in the carbon dioxide from Julius Caesar's last breath as he was murdered 2000 years ago might have ended up in the potato you ate the other day and are now part of you? Or that carbon dioxide that Haile Gebreselassie breathed out during a race perhaps ended up in some sugar cane and the carbon atoms are now part of you? Every atom in your body has been in many other bodies before it was in you. We are very much second-hand!



Figure 2.2 Caesar's dying breath

Figure 2.3 Energy and materials are moved around in an ecosystem

**DID YOU KNOW?**

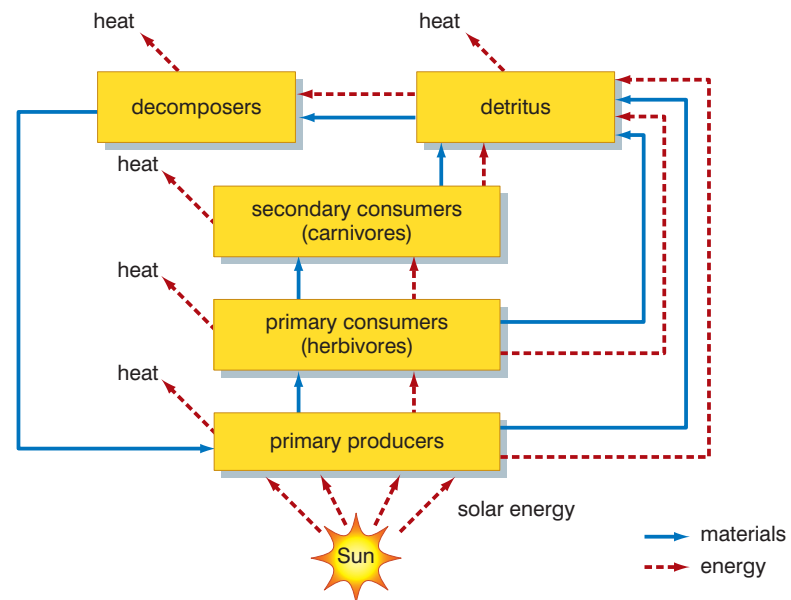
Decomposers release many mineral elements, nitrogen, phosphorus and others from organic compounds in dead bodies. These are then absorbed from the soil by plants. However, carbon is released into the air as carbon dioxide when the decomposers respire – just as with all other organisms.

There is a finite amount of each nutrient in an ecosystem and so the same atoms must constantly be re-used, over and over again. This happens at the ecosystem level and also globally. Ecosystems look unchanging, but they are in fact always changing. Materials are always being 'moved around' within an ecosystem. Nutrients are always being taken in by organisms and materials are lost when they breathe and excrete. What is a waste product to one organism becomes a vital nutrient to another. All the organisms in the ecosystem are interdependent and interact with their physical environment. Materials are moved around an ecosystem when organisms:

- feed
- excrete
- respire and breathe
- die and are decomposed

The molecules that are moved around, particularly the organic molecules, store large amounts of energy in the bonds holding the atoms together. So, as materials are moved, energy is transferred also. But, as noted earlier, energy is eventually lost from the ecosystem as heat and must be replaced as light. The nutrients just keep on being recycled ...

As you can see from Figure 2.3, **decomposers** (bacteria and fungi) are key in returning nutrients to the ecosystem. Important mineral elements such as nitrogen and phosphorus are returned to plants as a result of the action of decomposers.



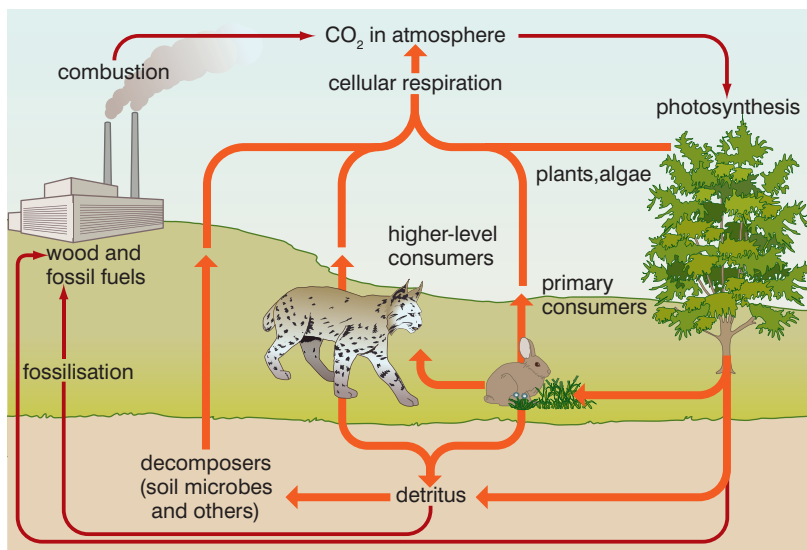
Decomposers feed by a method known as **saprobiotic nutrition**. They feed on dead matter – and so do you. You digest the parts of dead animals and plants that you eat and so must the decomposers. To do this, they secrete enzymes onto the dead matter. The enzymes digest the complex organic molecules into simpler, smaller ones and the micro-organisms absorb these products of digestion (just like you). But, unlike you, their **extracellular digestion** does not take place in a gut, it takes place in the soil, or wherever the dead matter happens to be.

However, besides hydrolytic enzymes that break down complex organic molecules many micro-organisms have enzymes for other purposes. For example, many of the decomposers have an enzyme that releases the amino group from amino acids and converts it to ammonia. This is known as ammonification and is important in the nitrogen cycle. But that is not why it takes place. Ammonification is carried out by a range of bacteria and fungi as a way of obtaining energy from organic, nitrogen-containing compounds. The ammonia, vital to the nitrogen cycle, is just a useless by-product to these micro-organisms. This is typical of many of the chemical reactions that take place in all the nutrient cycles. The reactions are primarily energy-releasing reactions for a particular type of micro-organism. It is a 'happy chance' that the reactions produce a by-product that can be processed in the next stage of the nutrient cycle.



**Figure 2.4** Fungi (moulds) decomposing bread using extracellular digestion

### What are the main stages in the carbon cycle?



**Figure 2.5** The carbon cycle

The main processes involved in cycling carbon through ecosystems are:

- photosynthesis – the process that fixes carbon atoms from an inorganic source (carbon dioxide) into organic compounds (for example, glucose)
- feeding and assimilation – feeding passes carbon atoms already in complex molecules to the next trophic level in the food chain where they are assimilated into (become part of) the body of that organism
- respiration – this releases inorganic carbon dioxide from organic compounds
- fossilisation – sometimes living things do not decay fully when they die due to the conditions in the soil, and fossil fuels (for example, coal, oil and peat) are formed
- combustion – fossil fuels are burned, releasing carbon dioxide into the atmosphere

#### KEY WORDS

**decomposer** an organism that breaks down dead organic matter and recycles it

**saprobic nutrition** used by organisms such as fungi to obtain nutrients from non-living organic matter using extracellular digestion

**extracellular digestion** organisms excrete enzymes to release nutrients from food and then absorb these nutrients through their cell walls

**Activity 2.1: Poster**

Farmers add fertilisers containing nitrates to the soil to replace the nutrients which crops remove. Excess fertilisers can be washed into lakes and rivers. This is called leaching. In the lakes and rivers, these fertilisers cause a process called eutrophication. In this process:

- the fertilisers cause algae in the river to grow faster
- they grow so much that they block out the light for plants underneath them, which die (due to competition for light)
- eventually the algae die also as they run out of nutrients
- the dead algae and dead plants become food for bacteria, which breed rapidly.
- the large population of bacteria respire, using up oxygen from the water.
- there is not enough oxygen left for organisms such as fish, which have to move to another area or die.

Use the information above to make a poster explaining the dangers of the overuse of fertilisers.

**KEY WORD**

**redox reaction** in a redox reaction, one chemical (called an oxidising agent) is reduced, and another chemical (called a reducing agent) is oxidised

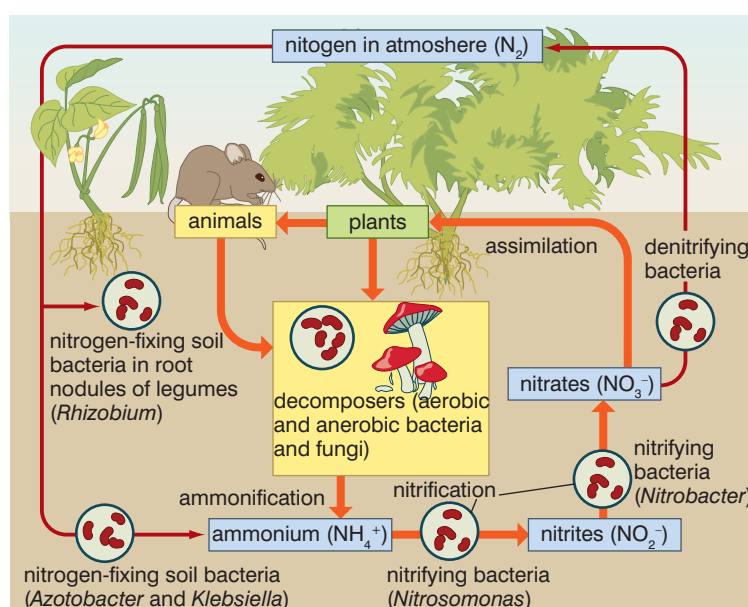
Cycling carbon is essential to the living world as all the organic molecules found in living organisms are based on carbon. We often talk about the Earth having 'carbon-based life forms'.

**What are the main stages in the nitrogen cycle?**

Nitrogen is found in many biological compounds. It is present in proteins, amino acids, DNA, RNA (all kinds) and adenosine triphosphate (ATP) as well as ADP.

Without nitrogen, organisms could not synthesise:

- their genetic material (DNA)
- their principal structural materials (proteins)
- their principal energy transfer molecule (ATP)



**Figure 2.6** The nitrogen cycle

The main processes in the cycle are:

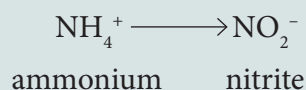
- plants absorb nitrates from the soil
- the nitrates are then used to form amino acids, which are used to synthesise proteins
- the plants are eaten by animals, the proteins digested and the amino acids absorbed and assimilated into animal proteins
- both plants and animals die, leaving a collection of dead materials (detritus) which contain the nitrogen still fixed in organic molecules; in addition, excretory products such as urea also contain nitrogen
- decomposers decay the excretory products and detritus, releasing ammonium ions (NH<sub>4</sub><sup>+</sup>) into the soil; this process is often referred to as ammonification
- nitrifying bacteria oxidise the ammonium ions to nitrates (NO<sub>3</sub><sup>-</sup>) (which are taken up by the plants) in a process called nitrification; in this process there is an intermediate product called nitrite (NO<sub>2</sub><sup>-</sup>)

**Remember redox reactions?**

The conversion of ammonium ions to nitrite ions is an oxidative process involving redox reactions, because the nitrogen atoms in the original ammonium ion:

- gain oxygen atoms and
- lose hydrogen ions

as the simple equation below shows



The hydrogen ions lost must go somewhere and the oxygen atoms must have come from somewhere, so something else is being reduced.

In actual fact, it is a much more complex reaction as the next equation shows! You will not have to remember this equation; it is just to illustrate how complex the reactions are and where the oxygen atoms come from and where the hydrogen ions go to.



The hydrogen ions reduce hydrogen carbonate ions to carbonic acid. The oxygen atoms that join the nitrogen atom are themselves reduced in the reaction.

Reduction and oxidation always occur together.

These processes recycle nitrogen that is already in biological molecules of one kind or another. But besides this, two other processes, denitrification and nitrogen fixation, decrease or increase, respectively, the amount of nitrogen in circulation.

**Denitrifying bacteria** reduce nitrate to nitrogen gas that escapes from the soil. This decreases the total amount of nitrogen available to the plants, and, therefore, to all the other organisms also.

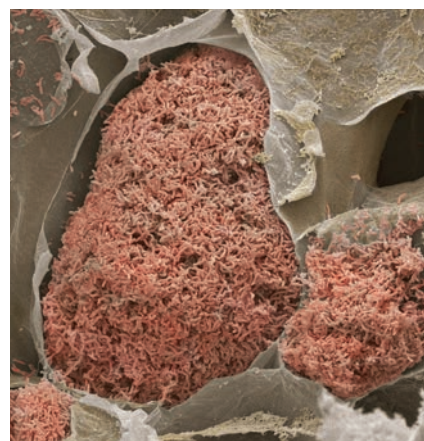
**Nitrogen-fixing bacteria** ‘fix’ nitrogen gas into ammonium ions. This happens in two main situations:

- Nitrogen-fixing bacteria free in the soil (belonging to the genera *Azotobacter* and *Klebsiella*) reduce nitrogen gas into ammonium ions in the soil. These ammonium ions can be oxidised immediately into nitrates by nitrifying bacteria, adding to the amount of nitrogen available to the plants and, therefore, the other organisms also.
- Nitrogen-fixing bacteria in nodules on the roots of legumes (belonging to the genus *Rhizobium*) form ammonium ions that are passed to the legumes and used by them to synthesise amino acids. The extra nitrogen only becomes available to other organisms when the legumes die and are decomposed.

Figure 2.7A shows the root system of a legume with nodules containing *Rhizobium*. Figure 2.7B is a micrograph of a section through the nodule showing the bacteria (stained purple).



**Figure 2.7A** Root nodules



**Figure 2.7B** The bacteria in a root nodule

**DID YOU KNOW?**

**Legumes** are often used in crop rotation systems by organic farmers. They can be used in one of two ways. They can be grown as a crop (for example, peas or beans) and the peas or beans harvested; then the remains of the plants are ploughed into the soil. Alternatively a non-crop legume such as clover can be grown and ploughed in at the end of the year. In this second method, all of the nitrogen fixed is added to the soil; none is lost in a crop.

At the moment an immense amount of research into the genetics of nitrogen fixation is being carried out. The aim is to isolate the genes that control nitrogen fixation and transfer them by genetic engineering into other cells. Or persuading bacteria like *Rhizobium* to form symbiotic associations with other species of crop plants. If all the cereal plants that are grown in the world had nitrogen-fixing bacteria in their roots or if their own cells could fix nitrogen, crop yields in countries with extreme food shortages would be hugely increased. And the plants would not need nitrogen fertiliser – they would make their own! Transferring this ability to other plants would have a huge impact on our ability to feed the planet.

**How is phosphorus recycled?**

The core phosphorus cycle is much the same as the core nitrogen cycle. Phosphorus is present in organisms in the form of phosphates.

- phosphate is absorbed from the soil (or water) by plants
- these are passed along food chains to various herbivores and carnivores
- on death, their bodies are decomposed and phosphate ions are released from compounds like phospholipids, ATP, DNA and RNA and are returned to the soil or water
- phosphates also enter the soil (or water) as a result of the weathering of rocks and in the form of fertilisers, which, themselves, contain phosphates that have been obtained from rocks
- over millions of years, phosphate ions can leach into the seas and become part of newly forming sedimentary rock.

**KEY WORD**

**legumes** (also called pulses) are food plants such as beans, lentils and peas

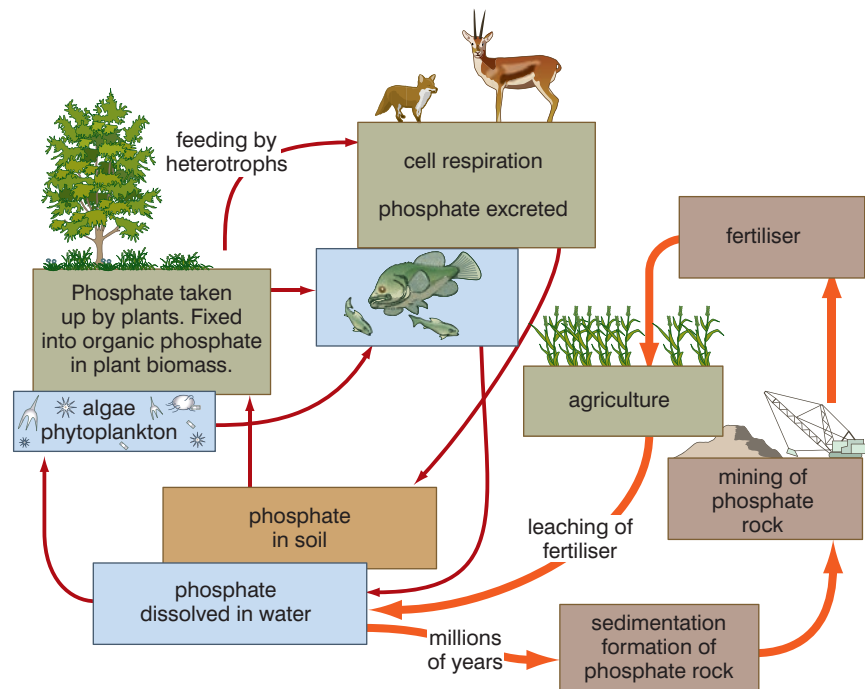


Figure 2.8 The phosphorus cycle

## How is sulphur recycled?

As with the other cycles, the core cycle is between the soil, plants, animals and special decomposers. There are also components that relate to long-term rock formation and weathering as well as the formation of sulphur dioxide when fossil fuels are burned.

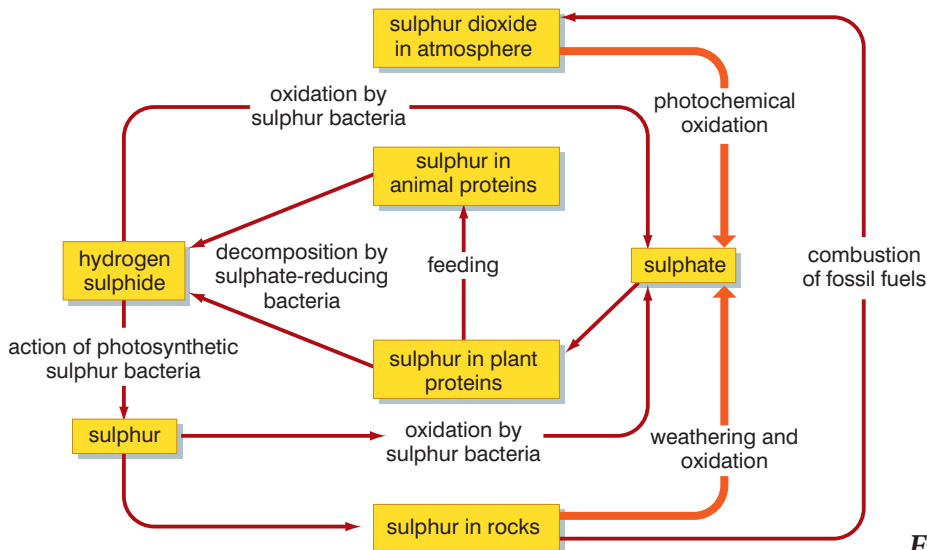


Figure 2.9 The sulphur cycle

- sulphate ions in the soil are taken up by plants and incorporated in plant tissue (many proteins include some sulphur-containing amino acids, such as methionine and cysteine)
- these are passed to animals by feeding and digestion
- on death of the plants and animals, sulphate-reducing bacteria release the sulphur in the proteins in the form of hydrogen sulphide (with the smell of 'bad eggs'); the most important genus of bacteria involved in this process is *Desulphovibrio*; this process requires anaerobic conditions
- in some aquatic environments the hydrogen sulphide is oxidised to sulphur by photosynthetic sulphur bacteria; this reaction is the equivalent of the photolysis of water in the photosynthesis of higher plants
- sulphur bacteria, mainly of the genus *Thiobacillus*, then oxidise the hydrogen sulphide (or sulphur) to sulphate ( $\text{SO}_4^{2-}$ ), with sulphite ( $\text{SO}_3^{2-}$ ) as an intermediate step; this is an oxygen-requiring process that needs aerobic conditions and makes sulphate ions available once again to be taken up by plant roots from the soil
- sulphur can also become incorporated in rocks, including those that yield fossil fuels
- combustion of fossil fuels oxidises the sulphur to sulphur dioxide ( $\text{SO}_2$ ); this is a serious pollutant of the atmosphere and a major contributor to the formation of acid rain
- in the atmosphere, the sulphur dioxide becomes further oxidised to sulphite and sulphate which dissolve in rainwater to form a mixture of sulphurous and sulphuric acid: acid rain

### Activity 2.2

Work in groups to make a big display of natural cycles. Each group should make a big poster on one of the natural cycles which can then all be arranged on the walls of the classroom as an aid to learning!

**Activity 2.3**

Prepare a report for the class on the importance of recycling in nature. You can investigate and add something about how people can recycle their resources too.

**What about the water cycle?**

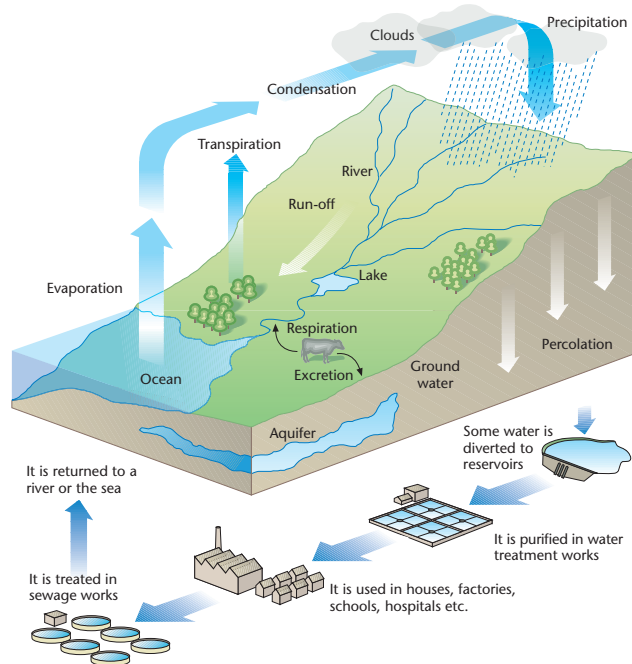
Water is essential to all living organisms in all kinds of ways:

- it makes up 70% of all cells
- it is an essential requirement of photosynthesis
- it is the basis of all transport systems in organisms
- it provides a means of removing excretory products

In addition, we use water in many ways in our daily lives:

- to wash our clothes, our dirty dishes and our dirty selves
- to flush away waste
- to make products such as paper, steel and beer
- to generate electricity using a range of devices that convert the motion of water into electrical energy
- in a system, called ‘hydroponics’, to grow plants in a soil-free medium

Figure 2.10 summarises the main stages of the water cycle.



*Figure 2.10 The water cycle*

**Review questions**

Choose the correct answer from A to D.

1. Which of the following statements about the nitrogen cycle is true?
  - A Plants fix nitrates into atmospheric nitrogen.
  - B All the nitrogen obtained by animals came from plants.
  - C Nitrogen is consumed by bacteria and removed from the soil.
  - D Nitrogen-fixing bacteria reduce the total amount of available nitrogen in the nitrogen cycle.



2. The micro-organisms that break down dead matter are:
  - A herbivores
  - B detritivores
  - C decomposers
  - D nitrogen-fixing bacteria
3. Carbon dioxide is removed from the atmosphere when
  - A animals respire
  - B plants respire
  - C plants photosynthesise
  - D Plants and animals respire
4. Decomposers feed by:
  - A parasitic nutrition
  - B saprobiotic nutrition
  - C intracellular digestion
  - D autotrophic nutrition
5. In the nitrogen cycle, nitrogen gas is returned to the atmosphere by:
  - A nitrogen-fixing bacteria
  - B ammonifying bacteria/decomposers
  - C nitrifying bacteria
  - D denitrifying bacteria
6. In the sulphur cycle, hydrogen sulphide is oxidised to sulphur by:
  - A photosynthetic sulphur bacteria
  - B *Desulphovibrio*
  - C *Thiobacillus*
  - D none of the above
7. Which of the following comparisons of the phosphorus *and* carbon cycles is true?
  - A The biological components of the cycles involve recycling through the atmosphere.
  - B The non-biological components involve the use of fossil fuels by humans.
  - C The non-biological components involve the agriculture industry.
  - D The biological components involve feeding, death and decomposition.

8. Which of the following statements concerning the water cycle are true?
  - A Aquifers are large underground natural reservoirs.
  - B Evaporation uses energy from the sun to vaporise liquid water.
  - C Run-off is the movement of water along the surface.
  - D All of the above.
9. Which of the following is the best explanation for the fact that decomposers are found in the carbon, nitrogen, sulphur and phosphorus cycles?
  - A They digest organic molecules.
  - B They feed on dead materials.
  - C They release mineral ions that are combined in complex organic molecules.
  - D They decay dead materials.
10. In the nitrogen cycle, it is accurate to describe the conversion of ammonium ions to nitrate ions as an oxidation because the nitrogen atom in the ammonium ion:
  - A loses oxygen and gains hydrogen ions
  - B loses oxygen and loses hydrogen ions
  - C gains oxygen and gains hydrogen ions
  - D gains oxygen and loses hydrogen ions

### KEY WORDS

**ecology** *the branch of science that describes and explains how organisms belonging to different species interact with each other and with the non-living environment.*

**ecosystem** *a community of organisms along with their habitat*

**succession** *the process where one ecosystem replaces another ecosystem*



**Figure 2.11** Lichens growing on bare rock

## 2.2 Ecological succession

By the end of this section you should be able to:

- Explain what is meant by the term succession.
- Describe the natural process by which bare land turns out to be productive by succession.
- Describe primary and secondary succession.
- Give examples of primary and secondary successions.

### What is a succession?

The **ecosystems** that exist today did not always exist. They have developed from other previous systems by **succession**. And many of them began on completely bare ground. Bare rock does not remain bare for long. Very soon, lichens can be seen growing on the surface of the rock. These extremely resilient organisms are able to colonise harsh environments and reproduce there. They are pioneer species.

Through the natural recycling processes we have discussed in section 2.1, the very presence of the lichens must change the **abiotic** conditions, making them less harsh. The living lichens grow into the rock causing it to crumble. When the lichens die, decomposers act on the remains to release mineral ions into the crumbled rock.

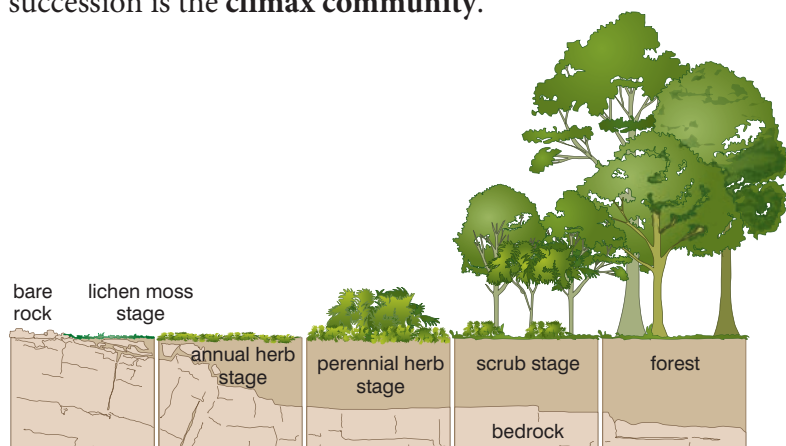
The mixture of dead remains, crumbled rock and mineral ions forms a primitive soil. This less harsh environment is suitable for mosses (provided that there is sufficient water). So, spores of mosses that land there can now 'germinate' and the mosses grow, outcompeting the lichens in the changed environment.

This is the essence of succession:

- Organisms colonise an area.
- They change the abiotic (physical) conditions in the area.
- The changed abiotic conditions allow other species to colonise the area.
- The new species compete with the ones there before and become dominant.
- They also then change the abiotic conditions, more species enter and the process continues.

The various stages in a succession are called seres.

As successive producers colonise the area, they create more and different habitats and niches for other organisms to occupy. As a consequence, succession usually involves an increase in the complexity of food webs. The final, most complex, state of a succession is the **climax community**.



**Figure 2.13** A succession from bare rock to a woodland climax

In the example shown in figure 2.13, you can see that as different types of vegetation enter the area, they affect the amount and depth of soil. This, in turn, allows other types of plant with more complex root systems to enter. The increasing complexity of the plant community will create more and more ecological niches and so more animals will also enter the area. The species diversity will rise through the succession, until the climax is reached. The climax is the most complex community that can exist under the prevailing environmental conditions.

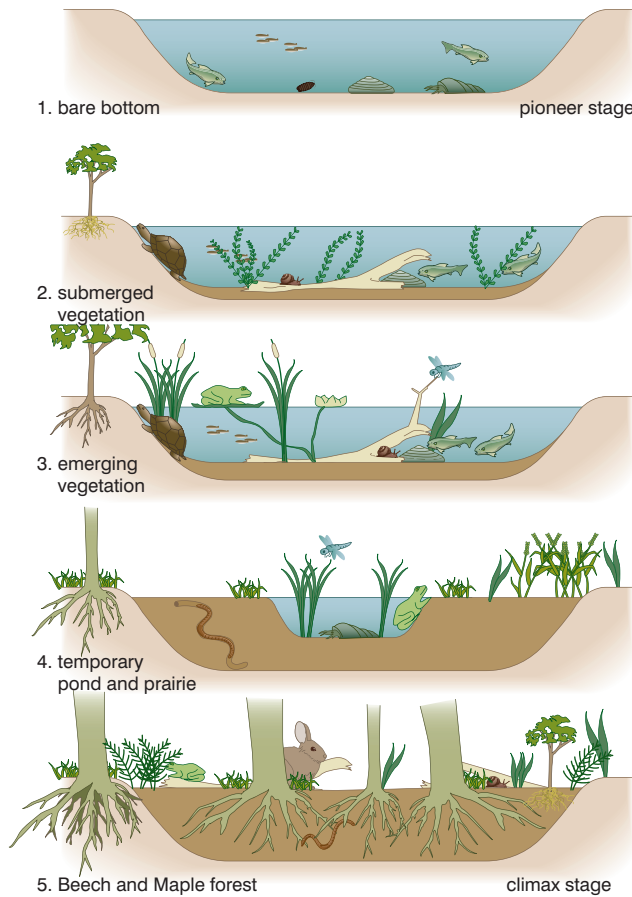


**Figure 2.12** Mosses have succeeded lichens in some areas

### KEY WORDS

**abiotic** describes the non-living part of an ecosystem

**climax community** the most complex community that can exist under the prevailing environmental conditions



**Figure 2.14** A succession from open water to woodland

The following trends occur in any succession:

- The total biomass of the community increases.
- The species diversity increases.
- The number of ecological niches increases.
- Food webs become more complex.
- The community becomes more stable – can accommodate small changes/losses more easily.

A woodland climax can arise through a totally different succession. A lake or pond can undergo a succession that results in the water being replaced by sediments allowing land plants to grow and giving rise to a succession that results in woodland. Figure 2.14 shows how.

An open water area with little obvious vegetation can support animal life because of plankton in the water and smaller animals in the mud at the bottom.

Submerged plants become established in the sediment formed by the dead animals. They increase the amount of sediment as they die and larger plants become established.

As time passes, more and more sediment fills the lake and larger ‘emerging’ plants become established. Eventually there is sufficient sediment to support deep-rooted trees and the climax woodland stage of the succession is reached.

Both successions end with the same climax. Because the first takes place from rock it is called a xerosere. The second, starting from water, is a hydrosere.

**The ecological impact of humanitarian acts**

Ethiopia has housed millions of refugees from other African countries. Many of these lived in large, specially created settlement areas. They are now, in most cases, being successfully repatriated to their native countries. But areas up to 40 km from the settlements have been deforested. They will probably revert, by a secondary succession, to the original native climax forest if left unmanaged.

**Why do different areas have different climax communities?**

Forest climax communities in Europe do not become as complex as tropical rainforest because of the climate. Because of this, they are said to be climatic climax communities.

Grassland in many areas would revert to woodland or forest if it were not grazed. The grazing animals nip off the growing points at the tips of young tree shoots, preventing them from growing. Grasses grow from ground level, not from the tips of shoots, and so can regrow. These grasslands are grazing climaxes. Other factors that could influence the type of climax community formed include:

- temperature
- precipitation (rainfall)
- soil type
- soil depth

Where a succession starts from bare, previously uncolonised ground, or from a newly formed pond with no life, the succession is a primary succession. Sometimes, communities are destroyed by fire or by a farmer ploughing a field or by some other human intervention. When a new succession begins in such an area it is a secondary succession. This may result in the same climax as was originally present or in a very different one. Although the process is still essentially the same (with pioneers colonising and then being succeeded), secondary successions to the original climax are usually much quicker than primary successions because:

- the succession is not starting from bare rock/open water
- there is a seed bank of many of the climax plant types available in remaining undamaged plants
- the soil is already present

### Review questions

Choose the correct answer from A to D.

- In an ecological succession:
  - pioneer species are the first to colonise an area
  - the most complex community to develop is the climax community
  - each stage in the succession alters the environment so that other species can enter
  - all of the above
- Which of the following factors does not affect the type of climax community that develops?
  - temperature
  - the presence of grazing animals
  - thunderstorms
  - soil type
- A secondary succession differs from a primary succession to the same climax in that:
  - it usually takes a greater period of time
  - it requires no pioneer species
  - there is an existing seed bank to draw on
  - it starts from ground that has never been colonised
- The stages in a succession are referred to as:
  - pioneers
  - seres
  - climaxes
  - communities

### Activity 2.4: Debate

Some people believe that clearing forests to create space for agriculture is always acceptable. Other people disagree with this because they believe it can reduce biodiversity. In this activity you will debate this issue.

Your teacher will divide the class into three groups:

- Group 1 – this group will present arguments to support the idea that clearing forests is always acceptable
- Group 2 – this group will present arguments to support the idea that clearing forests will reduce biodiversity
- Group 3 – this group will form the ‘audience’ who will:
  - question the members of each of the other groups after their presentation
  - vote to decide the outcome of the debate

The debate will follow the following procedure:

- Group 1 will present their case (2 minutes)
- Group 2 will present their case (2 minutes)
- Groups 1 and 2 can question the other group and try to disprove their ideas (2 minutes)
- Group 3 (the audience) can question any members of any group (4 minutes)
- Group 3 votes on the issue

5. All successions share which of the following features?
- A Each stage changes the abiotic conditions.
  - B The community becomes more complex as the succession progresses.
  - C More ecological niches are created as the succession progresses.
  - D All of the above.

## 2.3 Biomes

By the end of this section you should be able to:

- Define the term biome.
- Name the major terrestrial and aquatic biomes.
- Describe the main features of each biome.
- Give examples of the flora and fauna of each biome.
- Appreciate the duty of care we have for the flora and fauna of the biomes.

### KEY WORDS

**biosphere** *all those parts of the Earth, including the Earth's crust, the seas and the atmosphere, where living organisms can be found*

**biome** *a climatically and geographically limited ecological area that consists of organisms that are adapted in similar ways*

### What is a biome?

In 1875, the geologist Eduard Suess first coined the term **biosphere**. He used this to describe the layer of the Earth's surface where life is found.

Today we also think of the biosphere as the integration of all the world's ecosystems. It is now evident that the biosphere is more extensive than we ever realised. From bacteria at hot sulphur vents miles beneath the sea surface to geese flying at heights of over 8000 metres (5 miles), vultures at heights of 11 000 metres (7 miles) and fish living at depths of 8000 metres (5 miles), the biosphere is a lot thicker than we once thought.

We divide the biosphere into a number of **biomes**. The concept of a biome brings together several ideas. A biome is a geographical or regional area with:

- a specific climate, and
- a specific soil type, and
- specific animals and plants that are adapted in similar ways to the abiotic conditions within the area.

Temperature and precipitation (rainfall) are the most significant climatic factors in determining biome type. These, in turn, are determined to a very large extent by geographical location.

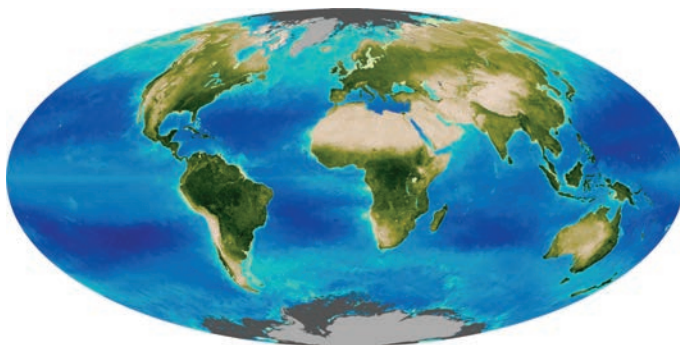


Figure 2.15 The biosphere

For example, it is never anything but cold at the poles, and these areas also receive little precipitation. It is never anything but hot at the equator and equatorial regions receive high precipitation.

Figure 2.16 shows how different combinations of temperature and precipitation result in different biomes.

Figure 2.17 shows how the main biome types are influenced by wind patterns, which are the main factors that drive the climate.

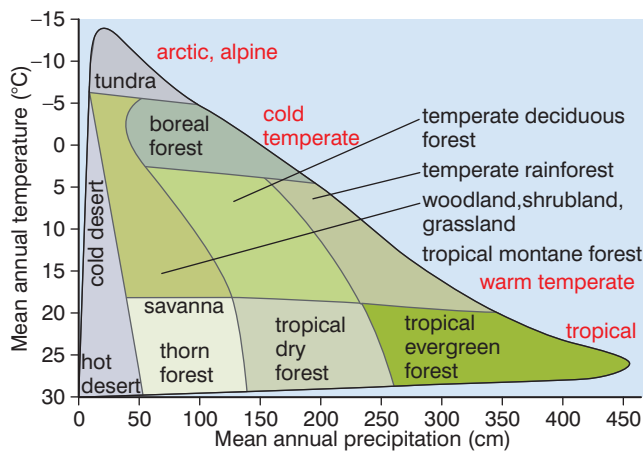


Figure 2.16 Temperature and precipitation are large factors in determining biomes

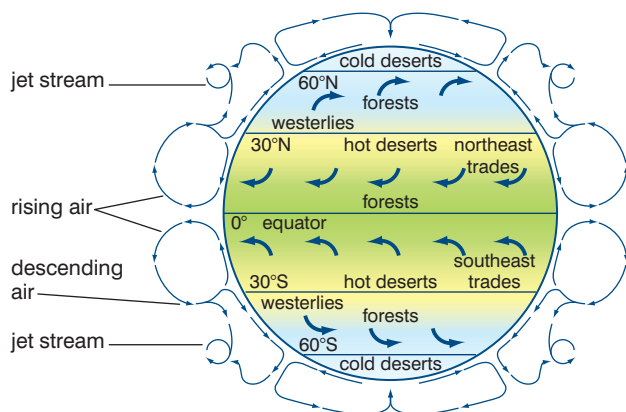


Figure 2.17 Biomes and their relation to the Earth's pattern of winds

### What types of biomes are there?

There have been many classifications of the different biomes and scientists are still refining their ideas but we can classify the biomes into two main types:

- terrestrial
- aquatic

Each can then be further subdivided to give the distinct biomes.

### What are the main types of terrestrial biomes?

A **terrestrial biome** is defined by temperature, rainfall, soil type, flora and fauna (plants and animals). Table 2.1 overleaf gives the features of the major terrestrial biomes.

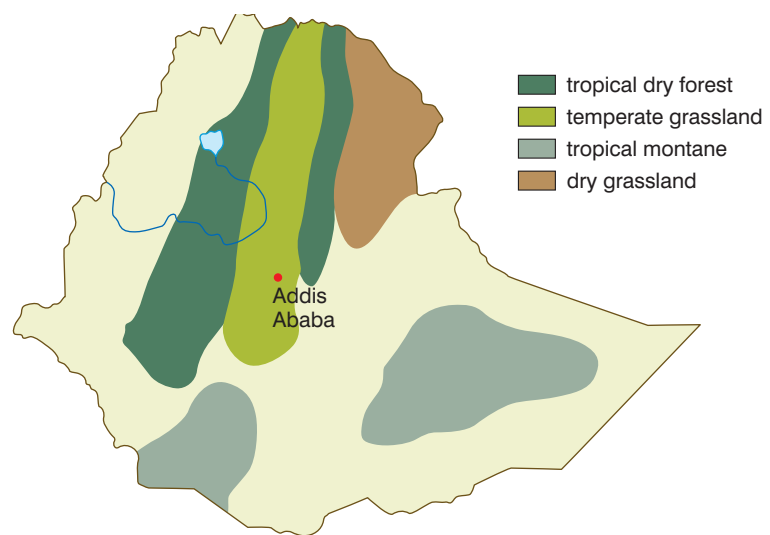
#### KEY WORD

**terrestrial biome** a biome consisting of an area of land

**Table 2.1** The characteristics of the major terrestrial biomes

Biome	Precipitation	Temp.	Soil	Plants	Animals
Desert (hot)	Almost none	Hot	Poor	Sparse – succulents (like cactus), sage brush	Sparse – insects, arachnids, reptiles and birds
Desert (cold)	Almost none	Cold	Poor	Sparse – micro-organisms and some lichens	Sparse – polar bears, seals
Thorn forest (scrub)	Dry summer, rainy winter	Hot summer, cool winter	Poor	Shrubs, some woodland (like scrub oak)	Drought- and fire-adapted animals
Tundra	Dry	Cold	Permafrost (frozen soil)	Lichens and mosses	Migrating animals
Boreal forest (Taiga)	Adequate	Cool year-round	Poor, rocky soil	Conifers	Many mammals, birds, insects, arachnids, etc.
Temperate deciduous forest	Adequate	Cool season and warm season	Fertile soil	Deciduous trees	Many mammals, birds, reptiles, insects, etc.
Tropical montane forest	8–9 wet months, air always humid	Always warm	Fertile soil	Ferns, tree ferns, large deciduous trees, epiphytes	Many animals
Tropical rainforest	Very wet	Always warm	Poor, thin soil	Many plants, epiphytes common	Many animals

There are several biomes to be found within Ethiopia. Wetter portions of the western highlands consist of tropical montane vegetation with dense, luxuriant forests and rich undergrowth.



**Figure 2.18** The main biomes in Ethiopia

**Activity 2.5**

Write the word *biome* on the centre of a piece of paper or of the chalk board. Build up a concept map or a spider diagram showing everything you know about the major biomes.



Drier sections at lower elevations of the western and eastern highlands contain tropical montane forest mixed with grassland. Temperate grasslands cover the higher altitudes of the western and eastern highlands. Tropical dry forest is found in the Rift Valley and eastern lowlands together with some dry grassland areas. Dry grassland also covers portions of the Denakil Plain.

### What types of aquatic biomes are there?

We can subdivide the **aquatic biomes** into two main types:

- **marine biomes**
- **freshwater biomes**

There are several biomes in each category. Table 2.2 gives some of the features of each category.

#### KEY WORDS

**aquatic biome** *a marine biome or a freshwater biome*

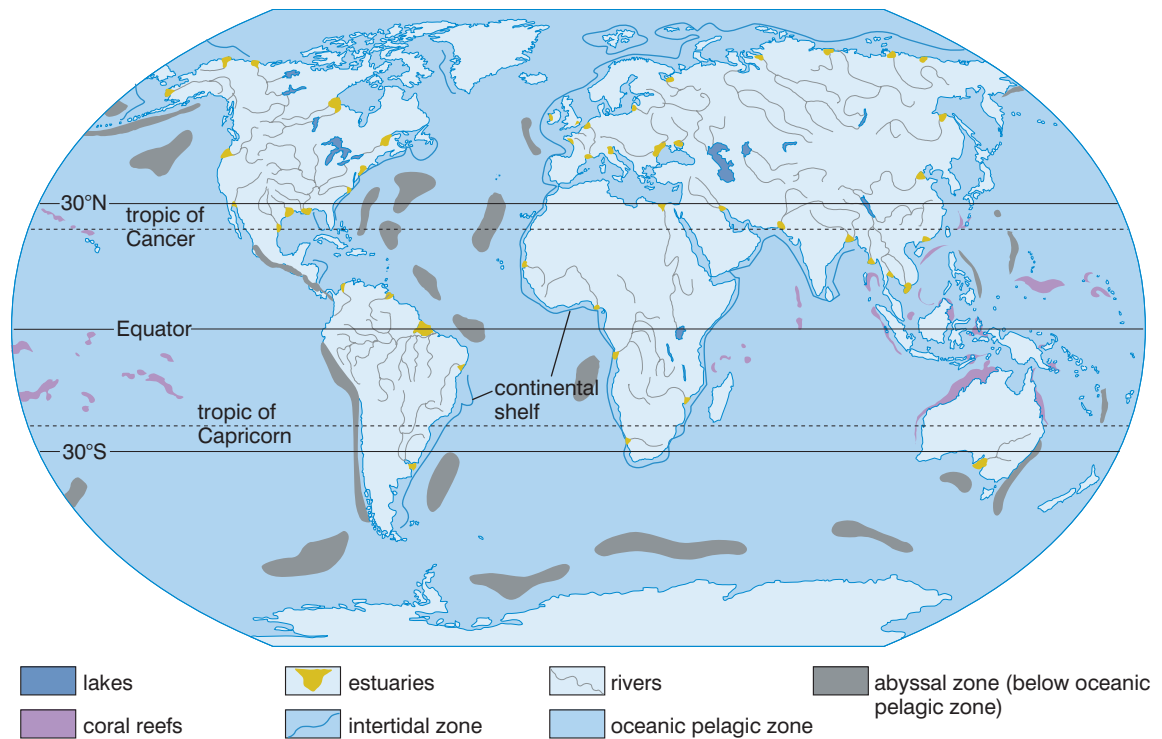
**freshwater biome** *a biome consisting of a river, a lake or a pond*

**marine biome** *a biome consisting of a part of the sea*

**Table 2.2** *The main features of the aquatic biomes*

Biome	Salt content	Moving or standing	Other feature	Animals and plants
<i>Marine:</i>				
Oceanic, pelagic	High	Moving	The region of the ocean where light penetrates	Many fish, mammals and plankton
Oceanic, abyssal	High	Less movement	The region of the ocean where no light penetrates	Angler fish, sulphur bacteria at vents
Coral reef	High	Moving	Most diverse of all marine habitats. Has many strata like a rainforest.	Corals, many fish, many seaweeds
Estuarine	Intermediate	Extreme movement	Unique habitat due to mixing of saltwater and freshwater	Shore birds, fish, crabs, mangroves, kelps, sea grass
<i>Freshwater:</i>				
Ponds and lakes	Freshwater	Standing	Are stratified as top layer absorbs more heat and light	Large numbers of plankton, plants and animals in top layer
Streams and rivers	Freshwater	Moving	Water is highly oxygenated	Algae, plankton, plants and fish
Wetlands	Freshwater	Standing	Water is very nutrient rich	Many plants and animals – highest of all aquatic biomes

Figure 2.19 shows the distribution of some of these aquatic biomes. It is clearly not possible to show the location of most lakes, ponds, rivers and estuaries.



**Figure 2.19** The distribution of the major aquatic biomes

### Review questions

Choose the correct answer from A to D.

1. A biome can best be defined as:
  - A a geographically defined region
  - B a group of ecologically similar organisms in a geographically defined region
  - C a geographically and climatically defined region
  - D a group of ecologically similar organisms in a geographically and climatically defined region
2. Terrestrial biomes are largely defined by:
  - A wind and temperature
  - B temperature and light
  - C rainfall and wind
  - D rainfall and temperature

#### Activity 2.6

Investigate a local biome – it may be terrestrial or aquatic. Find out as much as you can about your chosen biome. You can collect and present material from the biome such as soil, specimen plants etc. Prepare a short talk on your local biome and explain how it fits in with the ecology of Ethiopia as a whole.

3. Tropical rainforest is characterised by:
  - A low rainfall and low temperature
  - B high rainfall and low temperature
  - C low rainfall and high temperature
  - D high rainfall and high temperature
4. Freshwater biomes include:
  - A ponds and lakes, rivers and wetlands
  - B wetlands, estuaries and rivers
  - C estuaries, ponds and lakes, and rivers
  - D pelagic zones, wetlands and estuaries
5. When compared with tropical dry forest, tropical montane forests have:
  - A a higher annual rainfall but a lower temperature
  - B a lower annual rainfall but a higher temperature
  - C the same annual rainfall but a higher temperature
  - D a lower annual rainfall but the same temperature

## 2.4 Biodiversity

By the end of this section you should be able to:

- Explain what is meant by the term biodiversity.
- Appreciate the significance of biodiversity, both globally and locally.
- Explain how biodiversity is threatened in many areas of the world.
- Explain the status of biodiversity in Ethiopia.
- Describe the principles of conservation.
- Reflect a concern towards biodiversity and the need for its conservation.
- Appreciate the interdependence of plant and animal biodiversity.
- Engage in a tree-growing project.
- Express willingness to participate in tree-growing activities in your locality.

**KEY WORDS**

**biodiversity** *the extent to which an ecosystem contains different species. Greater biodiversity makes an ecosystem less vulnerable.*

**index of diversity** *a number indicating an ecosystem's biodiversity*

**What is biodiversity?**

The most usual way to think of **biodiversity** is in terms of species richness. This is quite simply the number of different species that are present in an ecosystem. However, if only one or two individuals of a particular species are present in an ecosystem, they won't be contributing a great deal to the biodiversity of the ecosystem. A more useful concept is species diversity. This takes into account, not just how many different species are present, but the success of each species in the ecosystem. An **index of diversity** can be calculated and this can be used to give a picture of the ecosystem as a whole.

Look at the examples in table 2.3 below. They are, of course, made up, but the figures serve to illustrate a point. Each area contains the same six species and the same total number of organisms (100) yet the areas are clearly very different.

**Table 2.3** Three 'invented' ecosystems

Species	Number of organisms of each species		
	Area 1	Area 2	Area 3
A	86	16	23
B	5	17	25
C	2	16	27
D	3	17	5
E	1	17	12
F	3	17	8

- In area 1, only species A is really successful and dominates the area.
- In area 2, all the species are more or less equally successful.
- In area 3, three of the six species dominate the area.

One **index of diversity** is Simpson's index of diversity and is calculated from the formula:

$$d = \frac{N(N - 1)}{\sum n(n - 1)}$$

In this formula, *d* is the index of diversity, *N* is the total number of organisms in the area and *n* is the total number of organisms of each species.

For area 1:

$$d = (100 \times 99) / [(86 \times 85) + (5 \times 4) + (2 \times 1) + (3 \times 2) + (1 \times 0) + (3 \times 2)] = 1.348$$

For area 2:

$$d = (100 \times 99) / [(16 \times 15) + (17 \times 16) + (16 \times 15) + (17 \times 16) + (17 \times 16) + (17 \times 16)] = 6.314$$

For area 3:

$$d = (100 \times 99) / [(23 \times 22) + (25 \times 24) + (27 \times 26) + (5 \times 4) + (12 \times 11) + (8 \times 7)] = 4.911$$

A low value for the index of diversity suggests an area dominated by one or just a few species. If there are more successful species with

no species completely dominating the area, the value for the index of diversity will be higher.

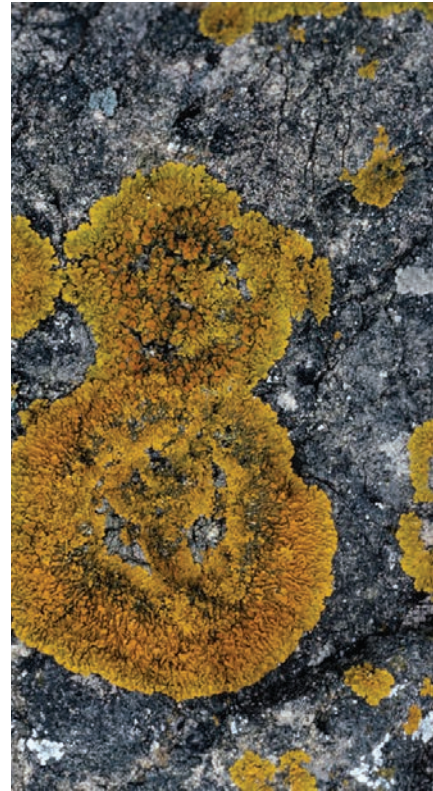
A low value for the index of diversity, suggesting only a few successful species, could be the result of a hostile environment with only a few organisms being really well adapted to that environment. Change in the environment would probably have quite serious effects. If those few species that can survive are seriously affected, then the whole ecosystem may be disrupted.

Think back to section 2.2 and our study of succession. At the pioneer stage, when lichens are colonising bare rock, there are no other organisms present.

There will be a very low index of diversity because of this hostile environment. If, due to some environmental change, the lichens do not survive, the fledgling ecosystem will be lost; nothing else is going to colonise the bare rock.

There might be only a few types of organisms because they outcompete other similar types that could survive in that environment. Rhododendron bushes very effectively prevent any other plant from growing in the same area by shading them so completely that they cannot photosynthesise; they also secrete chemicals into the soil that inhibit the germination of other seeds. As a result, rhododendron bushes completely dominate the areas in which they grow and the areas have a very low index of diversity.

A higher diversity index suggests a number of successful species and a more stable ecosystem. More ecological niches are available and the environment is likely to be less hostile. Environmental change is likely to be less damaging to the ecosystem as a whole unless it affects all the plants present. Tropical rainforests provide an example of a stable ecosystem with high species diversity.



*Figure 2.20* Lichens growing on bare rock



*Figure 2.21* Tropical rainforest has a high species diversity

**KEY WORD**

**tropical rainforest** *a biome at a low elevation above sea-level, high rainfall and warm temperatures all year round*

However, biodiversity isn't just about the numbers of different species and how well they are doing. It is also about the diverse ways in which these different species are found. So we must also consider:

- the ecological diversity of each species – how many different ecological niches has it managed to colonise?
- the genetic diversity of each species – is there just one strain of the species with essentially one set of genes (the gene pool) or are there several different (but related) gene pools because there are several different (but related) populations of the species living in different areas?

So, biodiversity is a measure of the overall variability of life on the planet (or a local area) and it includes:

- the species richness and species diversity of the planet (or the local area)
- the ecological variability of each species
- the genetic variability of each species

**How have humans influenced biodiversity?**

Only for the worse. We humans have influenced our environment much more than any other species. This is one of the key features of human evolution. We have not so much adapted to our environment by natural selection, as changed the environment to suit us. Until relatively recently, because of the small numbers of humans, this has not been too much of a problem. However, the rate of this change has accelerated with the huge increase in our population and the development of our technology. We have reduced biodiversity in many ways, but two important activities have been:

- deforestation, and
- the impact of agriculture.

**How has deforestation affected biodiversity?**

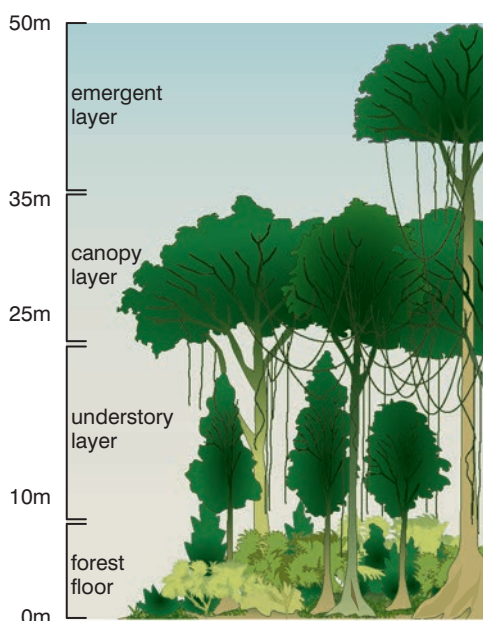
Where have all the trees gone? Gone for timber every one. Well, not quite; some have gone to be pulped to make the paper for biology textbooks, or simply to make room for ever more humans.

Deforestation is usually carried out for one of two main reasons:

- to clear land for human activities, such as mining, agriculture or house building, or
- to obtain timber to make products such as paper, charcoal, furniture, or to use as a building material.

**Tropical rainforest** is one of the most complex and species-rich ecosystems in the world. Rainforest covers about 7% of the Earth's surface and contains 25% of the known species.

Although many of the trees are very tall, the root systems are shallow and trees can easily fall. The shallow root systems grow in shallow, nutrient-poor soils. The soils are nutrient poor because many of the minerals from the soil remain 'locked up' in the huge trees. The only



**Figure 2.22** *The structure of rainforest*

recycling of nutrients that occurs on a regular basis takes place when leaves fall. There is no accumulation of detritus as decomposers rapidly break down the leaves and release the mineral ions they contain. The roots take these up, leaving few mineral ions in the soil. As a result, when the forest is cleared for agriculture, crop yields are often poor after the first year and more forest must be cleared. Tropical rainforest is the most productive of natural land ecosystems. The net primary production (biomass produced allowing for losses due to respiration) is  $2.2 \text{ kg m}^{-2} \text{ y}^{-1}$ , nearly twice that of temperate forests.

Felling tropical rainforest has far-reaching effects.

- There is a serious reduction in species diversity. Many ecological niches are destroyed when trees are felled and the species that fill these niches are lost. This reduces the biodiversity of the area.
- There is a reduction in the rate at which carbon dioxide is removed from the atmosphere. In addition, if the trees are burned, then carbon dioxide is added to the atmosphere. The local and global cycling of carbon is therefore affected.
- There is a reduction in the amount of nitrogen returned to the soil. The nitrogen fixed in the proteins and other compounds in the massive tree trunks remains fixed in a table in London, New York or Addis Ababa. Any tree trunks not removed from the area are slow to decay and the soil is depleted in nitrate for many years.
- A secondary succession will take place. If the felled area is allowed to regenerate, then seeds of many species of plant from the shrub layer will germinate. Ordinarily, the shrub layer is limited because the canopy prevents much of the light from reaching lower levels. If the shrub layer is allowed to dominate, this could give rise to a less complex ecosystem with a lower biodiversity.

The felling of trees need not be totally destructive and the practice need not be halted. However, the rainforests must be conserved and felling and replanting in a planned cycle over a number of years can do this. This could give a sustainable yield of timber, without endangering the species diversity of the rainforests.

One practice that has been adopted is to fell a strip of forest approximately 20 m wide and take the felled trunks to the sawmill for processing. This strip of land is not touched again for 20 years. In those 20 years, a secondary succession will have produced 'secondary forest' and the 20-year-old trees can be felled. For the intervening 19 years, other strips of forest are felled. Some areas are left completely untouched and act as a seed bank and core area, maintaining all ecological niches for the whole area.

### What are the effects of agriculture on biodiversity?

The effects of large-scale agriculture often follow the same pattern. Large areas of land are given over to the production of just one crop plant, such as maize or another cereal. This inevitably brings a reduction in biodiversity for several reasons, including:

#### DID YOU KNOW?

It is estimated that, currently, 20% of the Amazon rainforest has been felled since 1970. This is expected to rise to 40% by 2025, leaving only 60% of the rainforest that was present in 1970. We're getting through it at an alarming rate!



*Figure 2.23 Strip felling is one form of sustainable felling*

**DID YOU KNOW?**

When anyone eats a quarter-pounder, they should bear in mind that to make that one burger using South American beef, it took:

- the clearing of 5 m<sup>2</sup> of rainforest (to create the grazing land for the cattle)
- the destruction of 75 kg of living matter, including 20–30 different plant species, up to 100 insect species and dozens of bird, mammal and reptile species.



**Figure 2.24** A quarter-pounder

- the area is dominated by just one species, drastically reducing the number of niches for other organisms to fill
- organisms that might live there are regarded as pests, as they reduce the crop yield and so they are controlled by the use of pesticides, and
- hedgerows are removed to create bigger and more productive fields; this reduces still further the number of habitats and niches and, therefore, reduces the biodiversity of the area.

Other changes in agricultural practices have also had major effects on biodiversity. Traditionally, crops were ‘rotated’ so that in a field one year a cereal would be grown, another year perhaps a root crop such as carrots, then in another year a legume such as beans and perhaps one year ‘fallow’ (just grass, no crop).

The rotation would be carried out with different timings in different fields, so that all crops were always available. This meant that different animals could find different habitats. However, the intensive farming of just one crop year after year, keeping pests at bay with herbicides and pesticides, reduces the habitats available. Such practices have been blamed for the decline and, in some cases, the local extinction of species.

**What is the status of biodiversity in Africa?**

Figures 2.25A and B show the mammal species richness and plant species richness in Africa, respectively.

You can clearly see that the two are related. Areas that have high plant species richness often also have high mammal species richness – and vice versa. The reason for this is not difficult to work out. We have just been talking about the way in which plants provide habitats and niches for animals. So the more different plants there are, the more different habitats and niches for animals (including mammals) there will be.

There is one important exception. Parts of South Africa have a very high plant species richness, but do not have a correspondingly high mammal species richness. This is the Fynbos of South Africa. Fynbos has one of the highest concentrations of plant species anywhere in the world. But the plants grow on very nutrient-poor soils. So there just isn’t the protein in the plants to support a large number of mammals. Some other facts concerning African biodiversity include:

- a quarter (1229 species) of the world’s approximately 4700 mammal species occur in Africa, including about 960 species in sub-Saharan Africa (SSA) and 137 species in Madagascar. The eastern and southern savannahs host large populations of mammals, including at least 79 species of antelope
- more than a fifth of the approximately 10 000 bird species in the world are found in Africa; about 1600 bird species are endemic to SSA



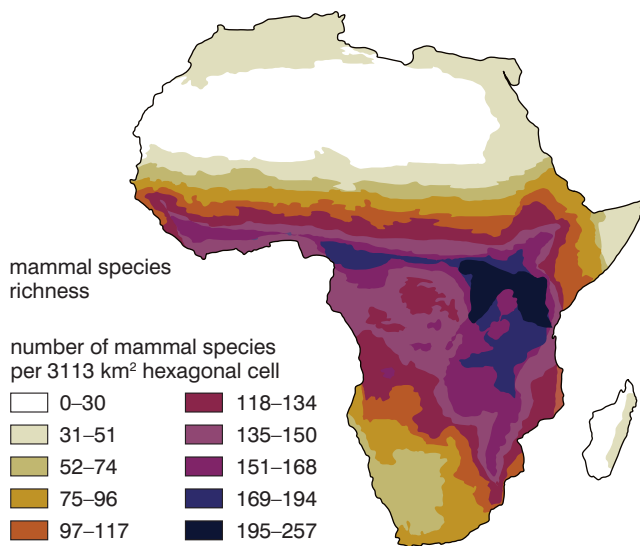


Figure 2.25A Mammal species richness in Africa

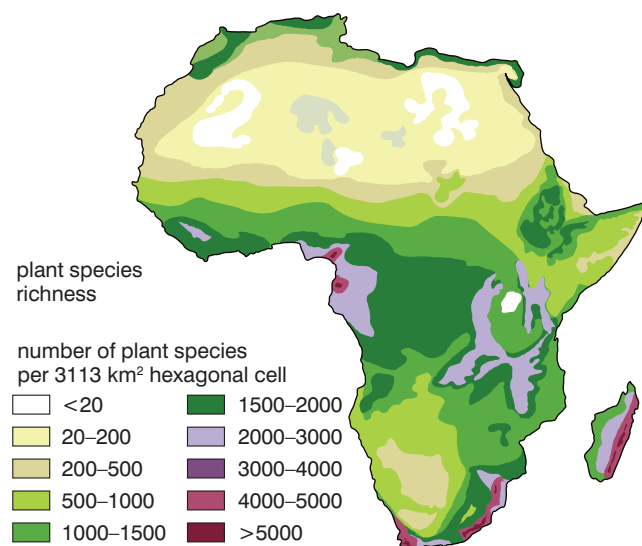


Figure 2.25B Plant species richness in Africa

- about 950 species of amphibians are found in Africa, making Africa (together with South America) the continent with the highest number of amphibians.

### What about – biodiversity in Ethiopia?

You can see from figures 2.25 A and B that biodiversity in parts of Ethiopia, compared to other African countries, is better than most, although not as high as in some nearby countries, such as Kenya.

Ethiopia is an important regional centre of biological diversity. The wide range in altitude and climate, the isolation of the highlands of Ethiopia, and the fact that there are so many different biomes present in the country, are some of the reasons for its high biodiversity. One estimate suggests that there are between 6500 and 6700 plant species in the country. This represents the fifth most diverse flora in Africa. About 10–12% of these plant species are endemic to Ethiopia (approximately 1150 plant species).

And the story of plant species richness doesn't end with wild plants in Ethiopia. Ethiopia is one of the 12 centres of origin (Vavilov centres) of cultivated crops. There are 11 cultivated crops, which have their centre of genetic diversity in Ethiopia. These are:

- *Coffea arabica* – Coffee
- *Eragrostis tef* – Tef
- *Ensete ventriculatum* – Ensete
- *Coccinia abyssinica* – Anchote
- *Guizotia abyssinica* – Niger seed (Nug)
- *Brassica carinata* – Ethiopian rape (Gomenzer)
- *Carthamus tinctorius* – Safflower (Suf)
- *Sorghum* Spp. – Sorghum
- *Hordeum* Spp. – Barley



Figure 2.26 Different varieties of coffee in Ethiopia

**KEY WORD**

**forage plant** a plant that is grown for animal feed

- *Linum usitatissimum* – Linseed (Telba)
- *Ricinus communis* – Castor bean (Gulo)

It is the efforts of the farmers of Ethiopia that have generated and maintained the diversity of crop plants in the country.

Ethiopia is also an important centre of genetic diversity of **forage plants**. About 46 legumes are endemic to Ethiopia. They include species of *Trifolium* (clover), *Vigna* (a type of bean) and *Lablab* (all parts of the plant are edible). These plants, used as animal feed, are important because they add nitrogen to the soil in which they grow as they have nitrogen-fixing bacteria living symbiotically in their roots.

The high species richness creates many diverse ecological zones with many ecological niches for animals to fill. Every group of vertebrate animals is well represented in Ethiopia as table 2.4 illustrates.

**Table 2.4** A summary of the vertebrate biodiversity of Ethiopia

Vertebrate group	Number of orders	Number of families	Number of genera	Number of species	Endemic to Ethiopia
Mammals	12	40	144	277	22
Birds	24	87	306	861	27
Reptiles	4	15	36	78	3
Amphibians	5	7	19	63	17
Fish	5	14	33	101	4

**KEY WORDS**

**species** a group of organisms that can interbreed to produce viable and fertile offspring

**genus** a group of closely related species (e.g. the genus *Felis* contains all species of small cats)

**family** a group of related genera (e.g., the family *Felidae* contains all cat-like animals, large and small)

**order** a group of genera that may differ but share some important attribute (e.g., the order *Carnivora* contains all carnivorous mammals, including the various cat-like mammals and dog-like mammals)

**endemic** an organism that is endemic to an area is always present and numerous in that area

There are other estimates of the numbers of orders/families/genera and species that differ slightly from that given in table 2.4.

In terms of the biodiversity of its avifauna (birds), Ethiopia is one of the most significant countries in mainland Africa. Again, Ethiopia's diverse ecology contributes to the tremendously diverse bird life. Over 861 species are found in Ethiopia. At present, 69 Important Bird Areas (which are also important for large numbers of other groups of animals) are identified by the Ethiopian Wildlife & Natural History Society (EWNHS). These include already existing protected areas and many other additional sites.

Such protection is necessary as the diverse bird life of Ethiopia is threatened, along with the overall biodiversity of the country as a result of a number of practices. Some of the effects of these practices have been direct, others have been indirect.

**Practices with direct effects on biodiversity:**

- deforestation – conversion of forests, woodlands and savannas to agricultural lands (for cultivation and grazing) and other land-use systems reduce the area available to native species
- fuelwood collection and illegal logging
- overgrazing by stock animals – reduces the availability of forage and woody plant species for other animals
- introduction of improved crop varieties – reduce the genetic

diversity of the particular crop plant as only the ‘improved’ variety is used

- overhunting (poaching) – directly reduces the numbers of the species hunted
- introduction of alien invasive species – these often outcompete native species for the available resources, sometimes making native species locally extinct

### Practices with indirect effects on biodiversity:

- high population growth – the more people there are, the bigger the demand for resources of all kinds, which puts pressure on land to be used for supporting humans, rather than other species
- undervaluation of the biodiversity resources – if biodiversity is not seen as important at all levels of government, then attempts to maintain biodiversity will not receive a high enough priority, this results in a lack of incentives for communities to conserve their local biodiversity
- legal and institutional systems that promote unsustainable exploitation – this results in big companies being able to make big profits from exploiting Ethiopian resources in a non-sustainable way; the resources won’t be there in the future as a result of these practices
- disregard of traditional communal (range) land management systems – traditional methods of land management conserved the species present and used them to support the community; these are at risk as more communities are encouraged to use more high-yielding, intensive practices

It is all too easy to paint a picture of doom and gloom with no hope on the horizon. But this would not be accurate. The Ethiopian government has been party to a number of initiatives relating to biodiversity. The eastern tropical montane forests of Ethiopia have been recognised as a hotspot for biodiversity conservation because of the exceptionally high concentration of endemic species and habitat loss. In 2005, the Ethiopian Institute of Biodiversity Conservation in Addis Ababa put forward a National Biodiversity Action Plan. This is a significant document running to 115 pages, which reviews the current situation and makes numerous recommendations. Some of these recommendations are listed below in two categories – those based on ecological considerations and those based on socioeconomic considerations.

### Ecological considerations

- Accelerate recovery by enrichment planting of target species in degraded remnant forests.
- Establish corridors to enhance the biodiversity and eventually the viability of fragmented forests, particularly in the central and northern highlands.

### DID YOU KNOW?

- About 87% of the highlands were once covered by forest, this was reduced to 40% by 1950 and 5.6% by 1980; more recent estimates suggest that there is now just 3% covered by forest.
- There have been local extinctions of several species as a result.
- The viability of fragmented, small populations of the forests remaining is questionable.

- Establishment of buffer zones (through tree planting) to stop further degradation of isolated forest fragments.
- Planting native woody species may be necessary on sites lacking of vegetation (for example, steep slopes).
- Establishment of tree plantations, which can serve as nurse crops, on highly degraded sites.
- Establishing area enclosures may be necessary to enhance natural regeneration and diversity of the native flora, particularly in arid and semi-arid regions.
- Control or eradicate (where possible) alien invasive species using integrated pest management.

### Activity 2.7: What should Ethiopia do?

Consider each of the recommendations in the 'socioeconomic considerations' section. Write a short paragraph explaining how each of these might address some of the issues listed in the 'practices that affect biodiversity' section.

### Socioeconomic considerations

- Allow meaningful participation by all stakeholders (people who have any interest in a particular course of action), including in decision making and implementation.
- Consider local socioeconomic needs in choices of approaches and options in matters impacting on local biodiversity.
- Strengthen local organisations.
- Make land and tree tenure completely secure.
- Formulate policies that promote sustainable utilisation and conservation of biodiversity.

### Why is biodiversity loss a concern?

In the years leading up to the millennium (2000) a global assessment of many aspects of biodiversity was made. It was called the Millennium Assessment (MA). The MA findings suggest that biodiversity loss contributes to:

- worsening health
- increasing insecurity of food supply
- increasing vulnerability
- lower material wealth
- worsening social relations
- less freedom for choice and action

### Food security

Biological diversity (the availability of many food sources) is used by many rural communities directly as an insurance and coping mechanism to increase flexibility and spread or reduce risk in the face of increasing uncertainty, shocks and surprises in the food supply. In a world where fluctuating commodity prices are more the norm than the exception, economic entitlements of the poor are increasingly becoming precarious. The availability of this food security net provides an important insurance program. Coping mechanisms based on indigenous plants are particularly important

for the most vulnerable people, who have little access to formal employment opportunities.

### Increasing vulnerability

Biodiversity can help with physical protection. Mangrove forests and coral reefs – a rich source of biodiversity – are excellent natural buffers against floods and storms. Their loss or reduction in coverage has increased the severity of flooding on coastal communities.

A common finding from the various assessments was that many people living in rural areas cherish ecosystem variability and diversity as a way of not being caught out by ecological shocks and surprises.

### Health

An important component of health is a varied and balanced diet. Thousands of species of plants and several hundred species of animals have been used for human food at one time or another. Some indigenous and traditional communities currently consume 200 or more species. Wild sources of food remain particularly important for the poor and landless to provide a balanced diet. Overexploitation of marine fisheries worldwide, and of bushmeat in many areas of the tropics, has led to a reduction in the availability of wild-caught animal protein, with obvious consequences in many countries for human health.

### Social relations

Many cultures attach spiritual and religious values to ecosystems or their components such as a tree, hill, river or grove. Thus loss or damage to these components can harm social relations – for example, by impeding religious and social ceremonies that normally bind people. Damage to ecosystems, highly valued for their aesthetic, recreational or spiritual values, can damage social relations, both by reducing the bonding value of shared experience as well as by causing resentment towards groups that profit from their damage.

### Freedom of choice and action

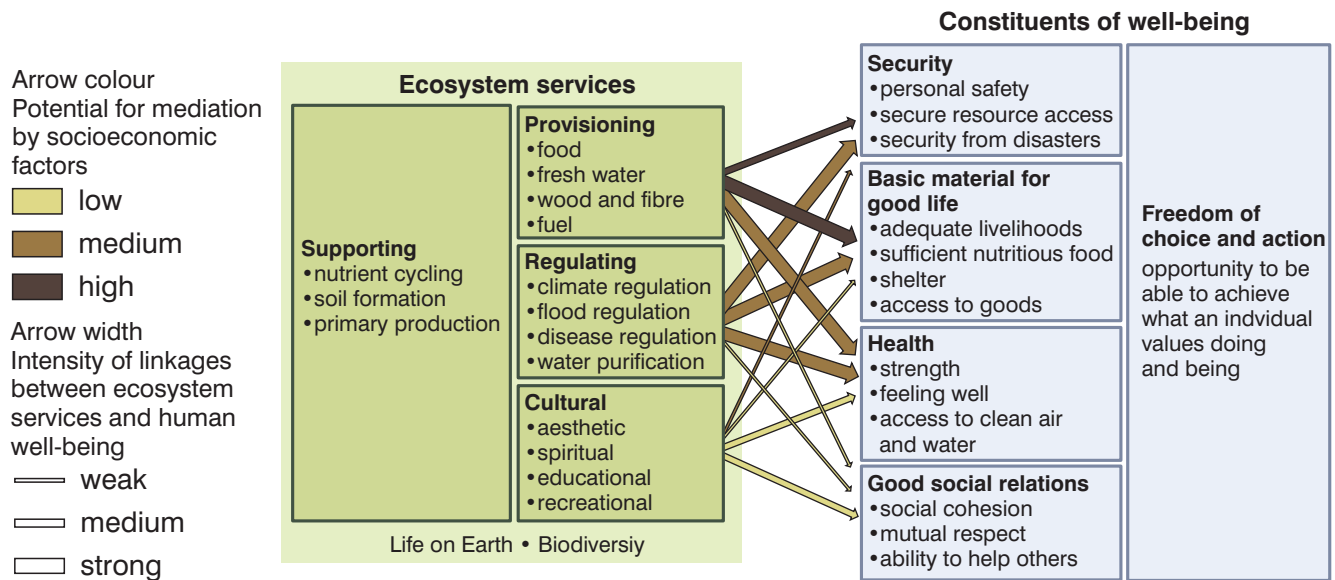
Freedom of choice and action within the MA context refers to individuals having control over what happens and being able to achieve what they value. Loss of biodiversity often means a loss of choices. For example, local fishers may depend on mangroves as breeding grounds for local fish populations. Loss of mangroves therefore leads to a loss in control over the local fish stock and a livelihood they may have been pursuing for many generations and one that they value. They may be forced into something else. Another example is high-diversity agricultural systems. These systems normally produce less cash than monoculture cash crops, but farmers have some control over their entitlements because

### Activity 2.8

In areas of biodiversity you will find lots of living organisms which are interdependent in a food web. EITHER chose a local environment which has a lot of biodiversity OR research a rich environment. Draw out a food web (like the one in fig 2.30) showing as many organisms as possible from your chosen environment.

of spreading risk through diversity. The loss of biodiversity is sometimes irreversible, and the value placed on keeping biodiversity for future generations can be significant. The notion of having choices available is an essential constituent of the freedom of choice aspect of well-being.

These benefits that humans gain from biodiversity are collectively known as ecosystem services. A loss of biodiversity will reduce ecosystem benefits locally and globally.



**Figure 2.27** Ecosystem services and human well-being

In addition to reduction in the ecosystem services described above, and summarised in figure 2.27, there are other dangers that result from the loss of biodiversity. The list is huge, but here are some examples:

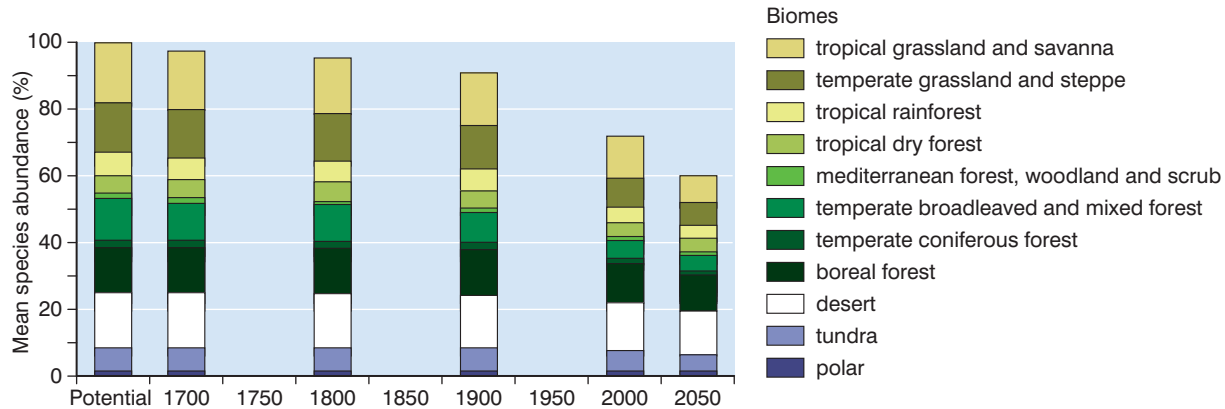
- continued felling of forests in some countries leads to increased flooding
- many medicines have been derived from plants; the oldest painkiller – aspirin – is derived from the willow tree – how many more are waiting to be discovered in plants we have not yet even named?
- the same holds true for animals; some sheep from South America produce anti-cancer drugs – again what other aids could there be in the millions of insects yet to be discovered?

Finally, we discussed biodiversity in the context of species diversity at the start of this section. If the number of species continues to be reduced, then this will ultimately lead to less complex ecosystems. Less complex ecosystems are less stable and more prone to ‘collapse’. Ecosystems will function less well if there are fewer species making them up.

### What can we do about it?

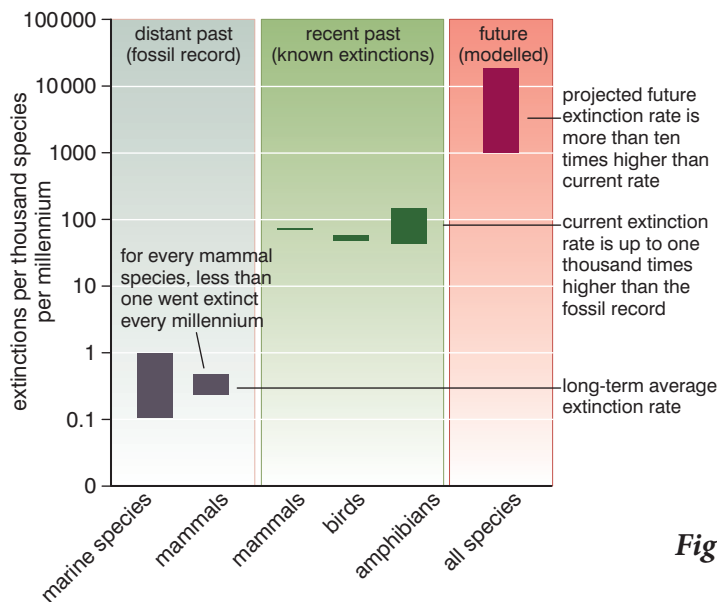
Is there still time? Can I have any effect at all? To answer that, you must understand the cost of doing nothing.

Figure 2.28 shows that, if we do nothing, and allow species extinctions to continue at the present rate, then there will be a serious reduction in biodiversity by 2050.



**Figure 2.28** The future of our biodiversity

When you look at any particular biome, there doesn't seem to be any huge projected change, and so it is easy to believe that we can just continue to do nothing. But look at the overall trend. Our biodiversity has fallen from 90% of its potential in 1900, to 70% in 2000 and it is projected to fall to 60% by 2050 and, carrying on the projection, to 50% by 2100, with most of this biodiversity in areas such as desert and tundra that are difficult to exploit. We are losing 10% of our biodiversity every 50 years. To help visualise this, if this loss of biodiversity were concentrated in just one place, it would represent an area just larger than all of the USA. And this is assuming that things don't get any worse – just that we continue to lose our biodiversity at the same alarming rate that we are losing it now. However, there is considerable evidence to suggest that the rate of species loss (and therefore loss of biodiversity) will actually increase in the future, as figure 2.29 shows.



**Figure 2.29** Past, present and future extinction rates

**KEY WORD**

**conservation** *the measures taken by people to preserve or restore an ecosystem*

**Activity 2.9**

Identify an area near your school or home where the environment has become damaged or polluted. Plan how your community could clear up the area to allow as much biodiversity as possible to return. Think carefully about what needs to be removed, what can be left, how to protect the area as it recovers and how to prevent the same problems happening again.

We cannot allow this to continue. We must **conserve** our biodiversity for future generations and appreciate that we have a duty of care to do so. Every future generation of humans has the right to enjoy and make use of the biological resources of the planet that are available to us today. This is the core principle of conservation. Conservation does not preach that we should not make use of the biological resources available, in fact it encourages us to make use of as many as possible. However, conservation demands that we use the resources in a sustainable manner so that future generations may do the same. Action is needed at individual, local, national and international levels to achieve this.

There are three guiding ideas of conservation:

- research – we must know what we are doing
- minimum intervention – the balances within and between ecosystems are delicate and can easily be upset, and
- repair rather than replace – it is always better to try to help an ecosystem to repair any damage rather than try to replace it.

The ecological principles that form the basis of conservation of biodiversity are:

- any protection of species and varieties of species will support biodiversity
- maintaining habitats is fundamental to conserving species
- large areas usually contain more species than smaller areas with similar habitats
- disturbances to habitats shape the characteristics of populations, communities and ecosystems, and
- climate change will increasingly influence all types of ecosystems.

The key to maintaining biodiversity will be to maintain habitats. If we can maintain habitats, the organisms will continue to visit them and live there. This will become increasingly difficult because of climate change, but, where possible, we should not allow existing habitats to become eroded and, if at all possible, should extend them.

To help conserve our biodiversity, we should also use our resources in a sustainable way. This means that we must not continue to:

- overfish the oceans; we must take only an agreed quota each year – but the types of fish eaten must become more diverse to provide the sheer tonnage demanded
- fell rainforest in the current manner; it must be felled sustainably, by strip-felling, for example
- reduce the genetic diversity of stock animals and crop plants by breeding only those that produce certain desired traits (lean meat, high milk yield, high grain yield)
- grow vast areas of cereals in monoculture



The above are examples only. You should try to think of other areas of our actions that need modification.

### What can I do for Ethiopia?

You can plant a tree. Now. Not next year – now. If you plant a tree now, and ensure that it grows, then in 20 years time there will be a mature plant that provides a habitat for a whole range of other organisms. You will see birds feeding and maybe nesting in your tree – but that is the very least of the increase in biodiversity that you will have encouraged. A complex **food web** in the soil will begin to develop because you planted the tree.

**KEY WORD**

**food web** *an interconnected collection of food chains*

If you don't really believe the extent of it – give your tree a couple of years, and then carefully examine some of the soil from around it. You'll be amazed at what you find.

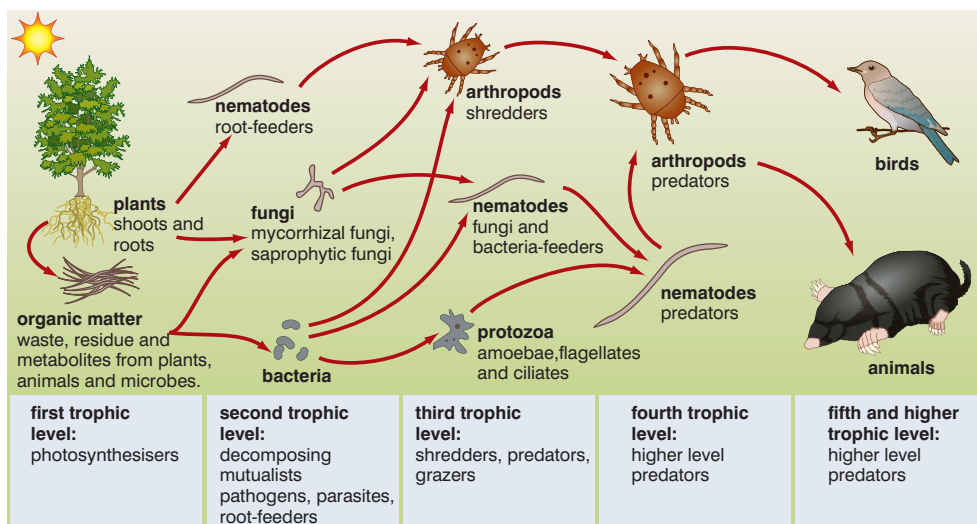


Figure 2.30 The soil food web.

If you want to do more, several of you could plant a little ‘copse’, but make sure that you do not plant the trees too closely together – they have to grow. If you were all to plant a tree a year, then in 20



Figure 2.31 Professor Legesse Negash, seen here planting a keystone indigenous tree, species *Ficus vasta* Forssk, at his Center for Indigenous Trees Propagation and Biodiversity Development in Ethiopia.

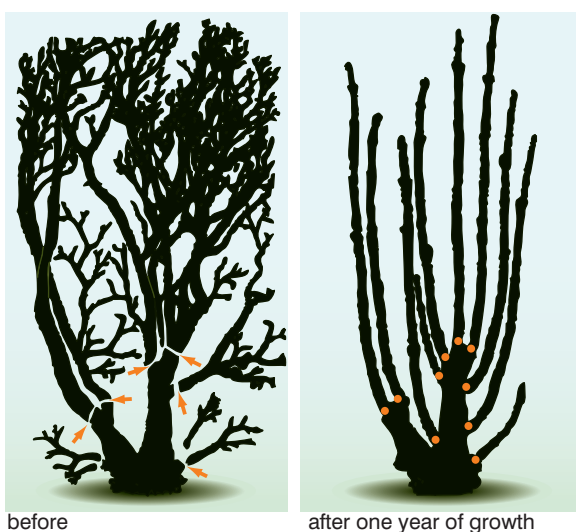
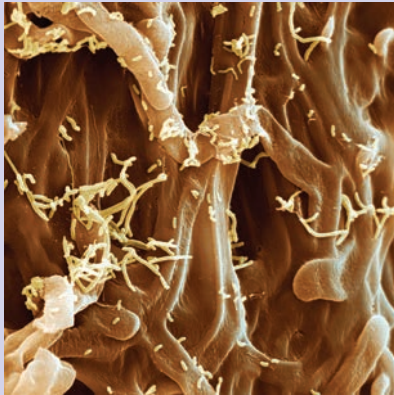


Figure 2.32 Coppicing trees for timber

years, you would have the makings of a sustainable woodland that could be coppiced every year for timber. Coppicing involves cutting back the shoots of the plant to about 10–15 cm above ground and allowing the stump to regrow. If you have this in mind, you must research which local trees are best for coppicing.



**Figure 2.33** A young tree seedling with an already extensive mycorrhizal network.

### DID YOU KNOW?

Mycorrhizae are symbiotic associations that form between the roots of most plant species and fungi. Organic molecules like sugars and amino acids pass to the fungus and inorganic nutrients move to the plant, thereby providing a critical linkage between the plant root and soil. The hyphae (threads) of the fungi grow around the root, greatly extending the area available for nutrient uptake, with some hyphae penetrating the root and, in some cases, individual cells. In infertile soils, nutrients taken up by the mycorrhizal fungi can lead to improved plant growth and reproduction. As a result, mycorrhizal plants are often better able to tolerate environmental stresses than are non-mycorrhizal plants.

### Activity 2.10: What can I do for Ethiopia?

You can organise a small group of friends to plant trees in your locality and see that they are regularly looked after until they are established. This will involve:

- regular watering
- checking for pest damage
- feeding the young trees (organic fertilizers are best) regularly

### Review questions

Choose the correct answer from A to D.

1. Increasing biodiversity could include increasing:
  - A species richness
  - B genetic variability
  - C ecological variability
  - D all of the above
2. Environmental change is likely to have most impact on:
  - A pioneer stages of successions because they have complex ecosystems
  - B climax stages of successions because they have complex ecosystems
  - C climax stages of successions because they have simple ecosystems
  - D pioneer stages of successions because they have simple ecosystems

3. A loss of biodiversity may affect well-being of rural communities in which of the following ways? It may:
  - A reduce food security
  - B reduce freedom of choice
  - C reduce physical protection
  - D all of the above
4. What percentage of our potential biodiversity is being lost every 50 years, at current rates?
  - A 5%
  - B 7%
  - C 10%
  - D 20%
5. Planting trees now could help conserve biodiversity in which of the following ways? It could:
  - A encourage the development of a soil ecosystem in the area
  - B encourage birds to feed and nest
  - C reduce timber taken from wild sources in the future
  - D all of the above
6. The high species richness of plants and mammals in Ethiopia is due largely to:
  - A the lack of disturbance
  - B the presence of several different biomes within the country
  - C efficient ecological management
  - D lack of predators
7. The key to conserving biodiversity is:
  - A using hardly any of the current biodiversity
  - B replacing any of the animals or plants we use
  - C maintaining habitats where at all possible
  - D using only specially bred stock animals and crop plants
8. Using a wide variety of food sources is beneficial to rural communities and the practice should be encouraged because:
  - A it is more likely to provide a balanced diet than using only a few
  - B it reduces the overall impact on each food species
  - C it is less likely to lead to shortages in food supply than depending on just a few sources
  - D all of the above

9. When compared to present rates of extinction, future rates are predicted to be:
- A the same
  - B one-tenth as great
  - C ten times as great
  - D none of the above
10. Continued felling of forest can:
- A reduce the biodiversity of an area
  - B increase the amount of flooding in an area
  - C allow erosion of the soil
  - D all of the above

## 2.5 Populations

By the end of this section you should be able to:

- Compare and contrast arithmetic and exponential growth.
- Compare intra-specific and inter-specific competition.
- Describe and explain the factors that influence the rate of population growth, including natality (birth rate) and mortality (death rate).
- Interpret a population growth rate curve.
- Define the term carrying capacity and appreciate the importance of the concept.
- Describe and explain the impact of rapid population growth on development.
- Describe measures that could and should be undertaken to control population growth.

### What is a population?

It's a much-used word – we talk of the world population, the population of Ethiopia, the population of Addis Ababa and so on. How can we use the same word in all these different contexts?

When biologists speak of a population, they have a specific meaning in mind.

*A population is all the individuals of a particular species in a particular habitat at a particular time.*

Populations are not static. Like ecosystems they are constantly changing. The cheetah population of Africa was once that – one extensive population. It suffered a 'population crash' about 10 000

years ago and is now effectively fragmented into several smaller populations (the high-density regions in figure 2.34). Cheetahs live in open grassland or savannah (their **habitat**) within a large **geographical range**.

And like ecosystems, the populations that are there now have not been there all the time. Remember the idea of succession? As the environment is modified (abiotic factors change) by plants present in an area, new species of plants colonise the area, establish themselves and outcompete the organisms that were there before and brought about the change.

### How can several populations live in the same area?

In a pond, there are populations of many different organisms. They are able to live in the same area because each exploits a different habitat in that area. For example:

- plankton exploit the open water regions of the pond
- decomposers inhabit the detritus found at the bottom of the pond
- snails browse the surface of the sediment at the bottom of the pond and graze small organisms

*A habitat is an area where a population lives and finds the nutrients, water, living space and other essential resources it needs to survive.*

Sometimes, different organisms can share the same habitat. However, they make different demands on that habitat. This combination of habitat and the demands made is called the ecological niche.

*The ecological niche of an organism describes its role within a habitat.*

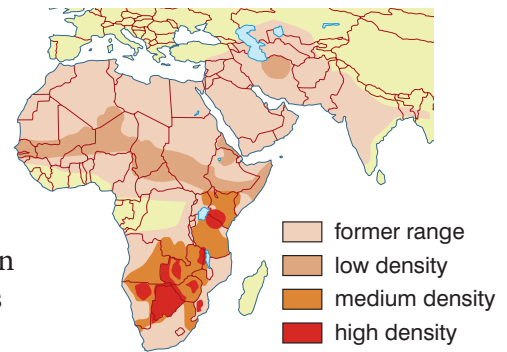
For example, both floating plants and tadpoles are found in the open water habitat. But the plants use sunlight, carbon dioxide, water and minerals from the water, whereas the tadpoles feed on the larvae of insects. They have different ecological niches.

In another example, both blue tits and great tits spend much of their time foraging in trees for insects and insect larvae. When one or the other species is present, they forage at about the same height. However, if both species are present in the same trees, they forage at different heights and so avoid competing for the same niche.

### What factors influence the sizes of populations?

As we have said, a population is all the individuals of a certain species in a certain habitat at a certain time. Anything which influences these numbers clearly affects the size of the population. There are three factors that directly affect numbers:

- natality – birth rate
- mortality – death rate
- migration – movement into (immigration) and out of (emigration) the area



**Figure 2.34** The changing cheetah population.

### DID YOU KNOW?

Research shows that two species cannot normally occupy the same niche. If two species are present initially, they will compete for the same available resources in the niche. One will be more successful and the other will be made locally extinct. This is called the **competitive exclusion principle**.

### KEY WORDS

**habitat** *the part of an ecosystem where members of a particular species live*

**geographical range** *the part of the Earth's surface where members of a particular species live*

### Activity 2.11

In ideal conditions populations simply grow. For example, bacteria reproduce by splitting in two. If they have everything they need, they can reproduce every 20 minutes. Calculate the number of bacteria there will be in 24 hours. However bacteria do not continue to grow at their optimum rate, otherwise they would take over the world. What factors do you think would stop them growing and eventually cause the death of the population?

Natality and mortality are clearly linked in their influences:

- if natality exceeds mortality (more are born than die), the population numbers will increase
- if mortality exceeds natality (more die than are born), the population numbers will decrease
- if mortality and natality are equal, the population numbers will remain the same

In a similar way, emigration and immigration are linked in their influences:

- if immigration exceeds emigration (more enter than leave), the population numbers will increase
- if emigration exceeds immigration (more leave than enter), the population numbers will decrease
- if emigration and immigration are equal, the population numbers will remain the same

Other factors influence mortality and natality. They influence how quickly a population increases in size or decreases in size. These factors can be divided into two main categories:

- **biotic factors** – the effects of other organisms of the same species or of a different species
- **abiotic factors** – the effects of factors in the physical environment (light, temperature, carbon dioxide concentration, oxygen concentration, physical space, etc.)

### Biotic factors

Some of the main biotic factors are:

- **predation** – the presence of a carnivore (predator) or herbivore, in the case of plants
- **disease** – infection by micro-organisms can reduce productivity and may be fatal
- **intra-specific competition** – competition between members of the same species
- **inter-specific competition** – competition between members of different species.

The ways in which biotic factors can affect population growth are summarised in table 2.5.

### Intra-specific competition

Intra-specific competition is the competition between members of the same species for some resource (often food) in the same habitat. In one example, gypsy moth caterpillars infested much of southern New England (on the west coast of the USA) in the summer of 1980.

**Table 2.5** The ways in which biotic factors can affect population growth

Biotic factor	How it affects population size
Predation	The presence of a predator (or herbivore in the case of plants) will effectively increase mortality and reduce the numbers in a population.
Disease-causing organisms	If disease is widespread, then mortality will be increased and population growth will be slowed.
Intra-specific competition	Competition between members of the same species can operate in two main ways: <ul style="list-style-type: none"> <li>• reducing the resources to all of the population can reduce their fertility and so reduce population growth, and</li> <li>• reducing the resources to just some of the population (as others compete more effectively) means that they die whilst the others reproduce, but population growth is still reduced.</li> </ul>
Inter-specific competition	Although the competitive exclusion principle states that two species cannot occupy the same niche, this is not absolute. The following can happen in appropriate circumstances: <ul style="list-style-type: none"> <li>• one of the two species outcompetes the other, which may die out</li> <li>• both species suffer a reduction as they are nearly equal in their ability to 'harvest' the resource and the effects of intra-specific competition for a reduced resource also come into play, or</li> <li>• the species are able to coexist.</li> </ul>

However, the density of this initial infestation was quite low, allowing most of the caterpillars to metamorphose into adults. The adults mated and laid masses of eggs (each mass containing several hundred eggs) on nearly every tree in the region. In the following spring, all the eggs hatched and the caterpillars began feeding. As they fed and grew, they stripped all the trees of their leaves.

The millions of caterpillars were soon competing for a very limited resource – any remaining leaves! As a result, their population crashed and very few caterpillars were able to metamorphose into adults.

Intra-specific competition is a major factor in controlling the populations of predators. In a typical predator–prey relationship when the population of prey begins to fall, there is intra-specific competition between the predators for the remaining prey, leading to a population decline. This allows the numbers of the prey to recover.

There can also be intra-specific competition between plants. In one experiment, different numbers of sunflower seeds were planted in the same sized pots. The number of live plants per pot and the mean plant height are shown in Tables 2.6A and 2.6B on the next page.

With increased numbers planted, there is increased intra-specific competition between the germinating seedlings, resulting in fewer, smaller plants surviving. This has applications in agriculture with packets of seeds of crop plants being supplied with recommended sowing densities to give maximum yields.



**Figure 2.35** Gypsy moth caterpillar feeding on a leaf

**Table 2.6A** Number of live plants

Time/days	Number of seeds per pot				
	2	4	8	16	32
7	2	3	6	11	24
14	2	3	6	11	24
21	2	3	4	10	22
28	2	3	3	8	20
35	2	3	3	7	17

**Table 2.6B** Mean height of plants per pot/cm

Time/days	Number of seeds per pot				
	2	4	8	16	32
7	8.5	7.5	6.1	5.2	4.8
14	9.3	8.3	7.2	5.9	5.3
21	18.9	16.2	11.4	9.6	7.3
28	20.2	18.6	14.6	13.4	11.3
35	27.4	22.5	17.4	16.3	15.2

**Activity 2.12: Verifying the results**

You can easily conduct this experiment yourself. All you need is:

- Five plant pots or similar containers (yoghurt cartons make a good substitute) with a top diameter of about 10 cm
- Soil or compost
- Small cereal seeds, such as barley or wheat

**Carry out the following:**

- Fill each container with the same amount of soil/compost.
- Plant different numbers of seeds the same depth (max. 1 cm) in each container, as below:

- pot 1 – 2 seeds per pot
- pot 2 – 4 seeds per pot
- pot 3 – 8 seeds per pot
- pot 4 – 16 seeds per pot
- pot 5 – 32 seeds per pot

Space the seeds as evenly as you can in the pots.

- Add the same amount of water (about 100 cm<sup>3</sup>) to each.

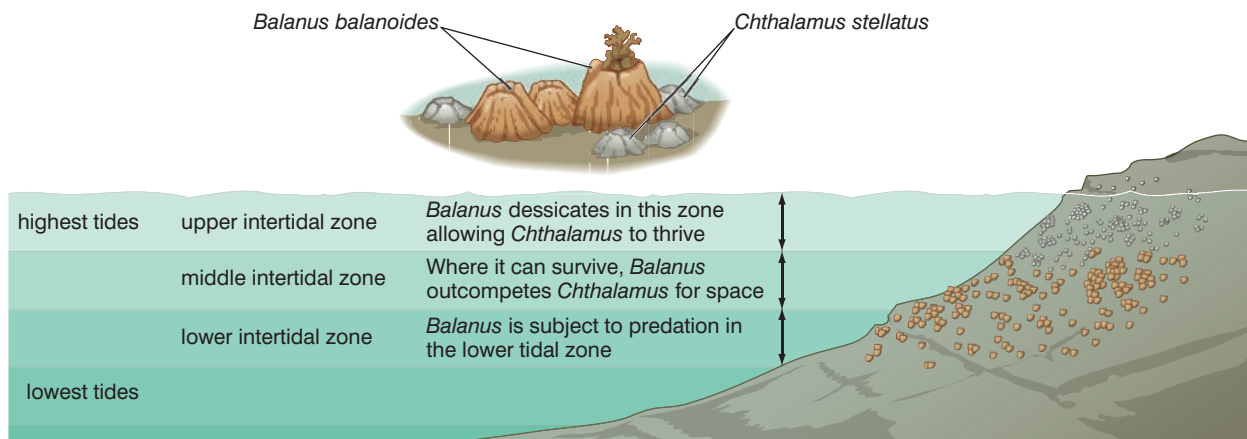
**Record:**

- The number of live plants per pot, and
- The average height of the live plants in each pot every seven days for 35 days.

**Inter-specific competition**

This occurs when two different species compete for the same resource in the same habitat. Although most organisms have their own ecological niche, there is very often some overlap between the niches of two species. Barnacles are a kind of crustacean that live on rocky shores. *Chthalamus* and *Balanus* are different species of barnacle. *Chthalamus* can live anywhere in the intertidal zone (between high tide and low tide). *Balanus* cannot live in the upper

**Figure 2.36** Inter-specific competition between two species of barnacles – *Balanus* and *Chthalamus*





intertidal zone (nearest the high tide region) as in this region it desiccates because it is out of water for too long. However, in the other regions, it outcompetes *Chthalamus* for the available resources, particularly space. This is summarised in figure 2.36.

On beaches where *Balanus* is absent, *Chthalamus* occupies all three zones.

Inter-specific competition also occurs in some areas of Ethiopia between the Ethiopian wolf and domestic dogs. In these areas both animals hunt rats and so compete with each other.

**DID YOU KNOW?**

**About a famous investigation into inter-specific competition in *Paramecium***

In 1934 G F Gause grew two different species of *Paramecium* (a unicellular organism) in a culture medium of oatmeal and yeast. Initially, he grew each species in isolation and monitored the population densities. Then, he grew the species together and, again, monitored the population densities. His results are shown in the graphs in Figure 2.37.

Gause concluded that if the two species utilise the same resource in the same way, then one will totally outcompete the other, which will become locally extinct.

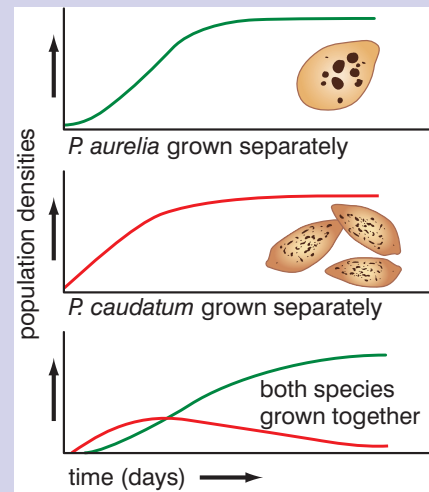


Figure 2.37 Results from Gause's experiments

**How do populations grow?**

All populations show the same pattern of growth. After an initial 'establishing' phase, they show what is called exponential growth, until they are limited by the environment. The difference between exponential and arithmetic growth is illustrated in table 2.7. In arithmetic growth, the numbers increase by the same fixed amount in each time period. This produces a uniform rate of growth over the time period. In exponential growth, the population doubles in each time period, producing an ever-increasing growth rate that is clearly not sustainable in nature.

Figure 2.38 shows populations increasing with:

- a slow rate of exponential growth (orange line)
- a fast rate of exponential growth (green line)
- arithmetic growth (red line)

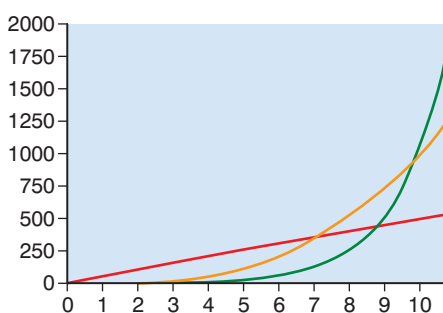
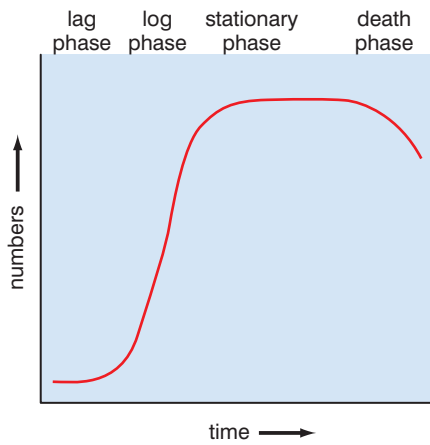


Figure 2.38 Different rates of exponential growth and arithmetic growth compared

Table 2.7 Arithmetic and exponential growth

Time period	Numbers in population	
	Arithmetic growth	Exponential growth
0	10	10
1	15	20
2	20	40
3	25	80
4	30	160
5	35	320
6	40	640
7	45	1280
8	50	2560

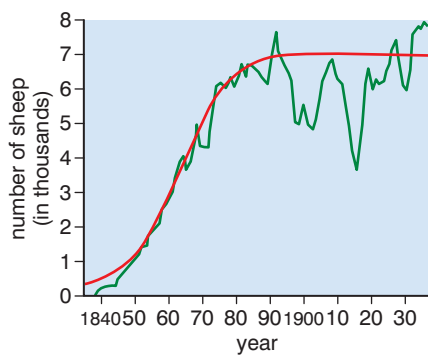


**Figure 2.39** The main phases in a population growth curve

As a result of the combined influence of some or all of the biotic and abiotic factors described above, most populations develop through four main stages, illustrated in figure 2.39. The four phases are also described in table 2.8.

**Table 2.8** The main phases of the growth curve

Phase	What is happening	Effect on population size
Lag	Population establishing itself; some organisms are not adapted to the environment and die, others reproduce.	Numbers remain low and static or increase slowly.
Log	All are adapted and reproduce rapidly due to plentiful resources.	Numbers increase rapidly.
Stationary	The carrying capacity is reached; the same numbers are dying as are produced in reproduction.	Numbers remain fairly constant; they fluctuate about a 'mean' level.
Decline	Nutrients exhausted, a new disease strikes or toxic excretory products accumulate.	Numbers decline rapidly.



**Figure 2.40** The growth curve of a sheep population in Australia

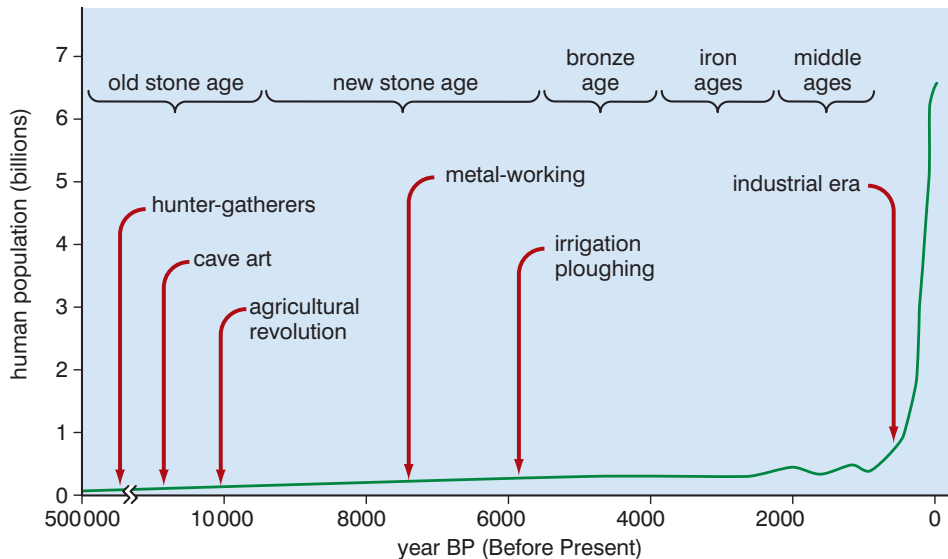
The curve shown in figure 2.40 is an idealised curve and not many populations actually grow exactly in that manner. Figure 2.40 shows an actual population growth curve for a population of sheep over a period of 30 years. The first two phases match the 'idealised' curve fairly closely, but the stationary phase is anything but stationary. It fluctuates quite widely from the idealised curve. Why is this?

To understand, we need to consider an idea mentioned in table 2.8 – that of 'carrying capacity'. The carrying capacity of a population is the number that the environment is capable of supporting (or 'carrying') at that time. This can change from year to year. In this case, if there is a year with lots of sunshine and rain to encourage growth of grass, the sheep may well be able to obtain more food and produce more lambs than they normally would. But then the increased population would need to be supported in subsequent years. And if environmental conditions deteriorated for a few years, the population could not be sustained and would fall.

### What about human populations?

Figure 2.41 shows the change in the human population over the past 500 000 years.

We have come from a population of less than 5 million 10 000 years ago to a population of 6 800 000 000 (6.8 billion) at the end of 2009. The population has been increasing particularly quickly over the



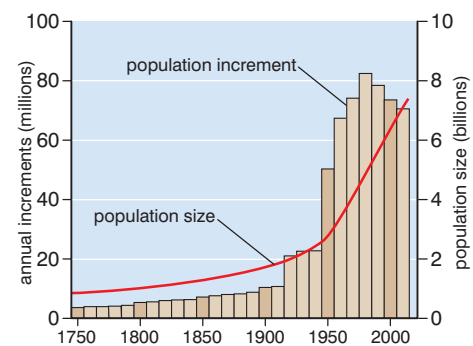
**Figure 2.41** The human population from 500 000 years ago to the present time

past two hundred years, because we have (generally) increased the quality and quantity of food available and we have decreased the impact of disease-causing organisms with improved sanitation and medical care. However, there can be no doubt that the human population has increased far too much and far too quickly. In countries with the highest population growth rates, the high growth rate is one factor in preventing or slowing development. The sheer weight of numbers makes it much more difficult to implement education programmes, health programmes, proper sanitation and all similar measures.

However, looking carefully at figure 2.42 shows that the rate of population growth is slowing. This should result in the numbers levelling at around 12 billion by the year 2200. This may sound like good news, but set this alongside the fact that estimates of the carrying capacity of the Earth for humans average at around 10 billion. There will still be too many of us.

The human population is subject to the same checks as other populations; the various biotic and abiotic factors still influence population size. However, the human population is subject to other factors affecting its development. These include the point at which the particular country or region develops agriculture and industrialisation. This affects growth rates, death rates and life expectancy.

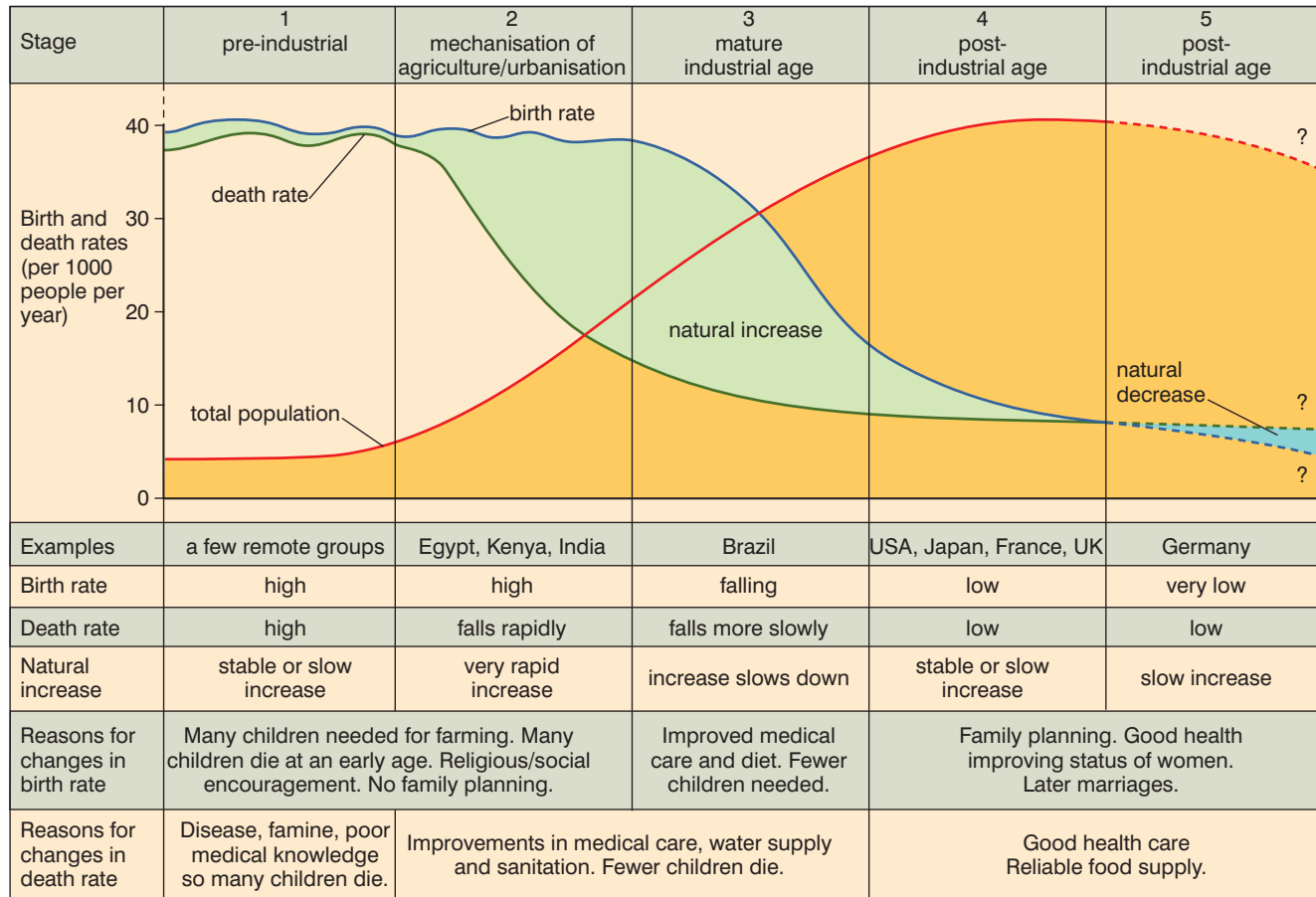
These changes are called the **demographic transition** and the stages of the demographic transition are shown in figure 2.43 overleaf.



**Figure 2.42** The annual increase in the human population

### KEY WORD

**demographic transition**  
a model that seeks to explain the transformation of countries from having high birth and death rates to low birth and death rates



**Figure 2.43** The stages of the demographic transition

Notice that in the second and third stages of the demographic transition, death rates fall before birth rates. This creates a period when the population is increasing. In the final stages, birth rates and death rates are low and the population is stable, with either a slow increase or a slow decrease.

Most developed countries are in one of these two final stages of the demographic transition, whereas developing countries are still in one of the two middle stages. As a result most of the population growth is occurring in developing countries. Rapid growth slows the transition to the later stages.

In the demographic transition, the relative numbers of young and old people changes. These are best shown in age pyramids. Figure 2.44 shows age pyramids for Afghanistan (a country still developing) and the USA and Italy (developed countries).

The broad base to the population in Afghanistan shows that large numbers of children are still being born and that the population is increasing. The structure in the USA is different. There are similar numbers in all the age groups until about age 60. This suggests that the numbers being born are slightly greater than those dying and the population numbers are increasing slowly. Can you explain the lack of growth in Italy? Notice also that life expectancy is greater in Italy and the USA. This is true of most developed countries. Figures 2.45A and B show the population pyramids for Ethiopia in 2000 and the projected population pyramid for 2025.

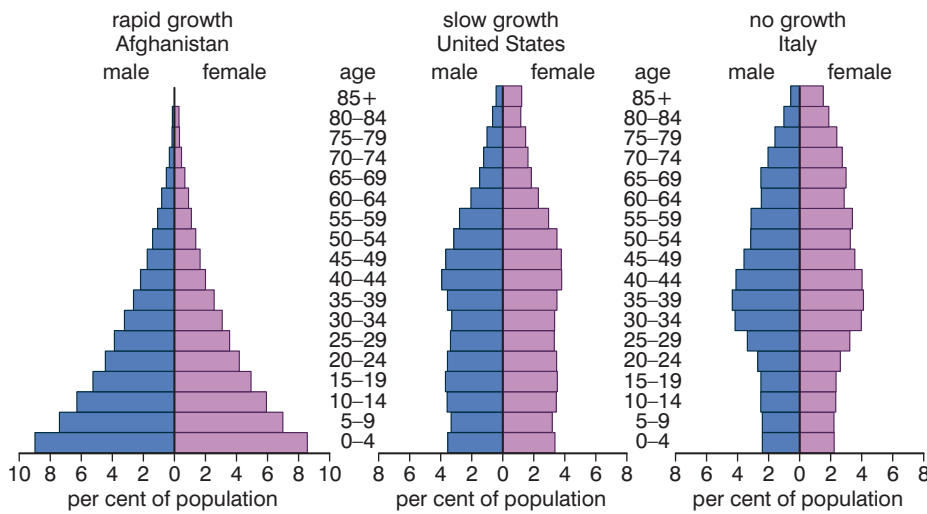


Figure 2.44 Age pyramids for Afghanistan, the USA and Italy

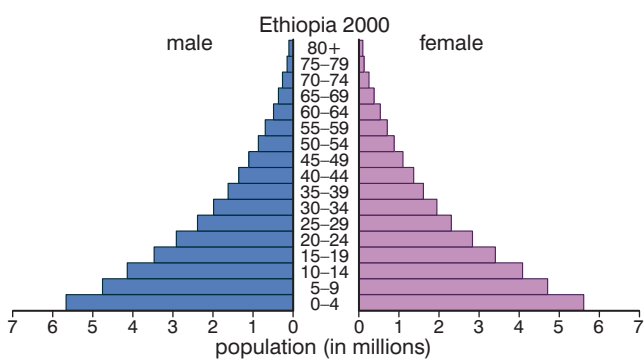


Figure 2.45A Ethiopia in 2000

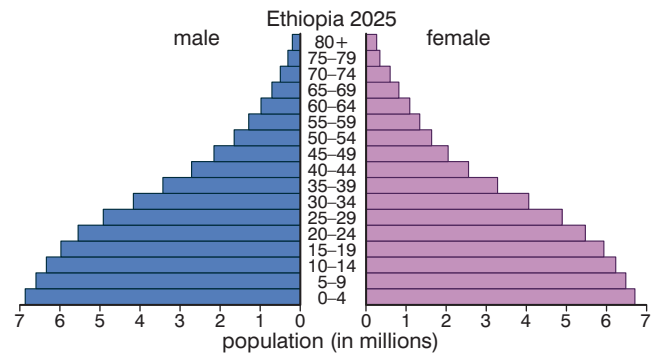


Figure 2.45B Ethiopia in 2025

Note that, although the population has increased (predicted by the structure of the population in 2000), the rate of increase is slowing. The base of the new pyramid shows several age bands of more or less the same size – typical of populations showing no growth.

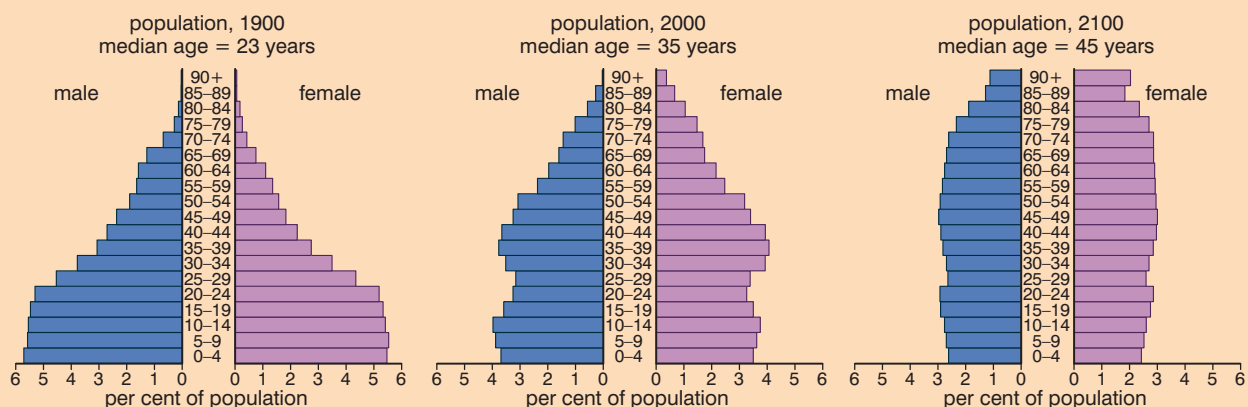
**Activity 2.13: Analysing population pyramids**

The three population pyramids in Figure 2.46 are of the same country in 1900, 2000, and the predicted structure for 2100. Describe precisely how each of the following changes with time:

- median age of the population

- the percentage of the population over 70 years of age
  - the overall shape of the population
- Use your knowledge of the demographic transition to explain these changes.

Figure 2.46



**KEY WORDS**

**natality** *the rate at which people or members of an animal species are born*

**mortality** *the rate at which people or members of an animal species die*

**What can we do about it?**

Whether the global human population increases or decreases depends on the balance between global **natality** and global **mortality**. There are no migration issues. We aren't going anywhere. So the mathematics is fairly simple; to reduce global population, either:

- mortality will increase; this is the 'do-nothing option' and we can wait until the population crashes or war is rife from competition for resources because we are so far over our carrying capacity, or
- natality must decrease – this is the only option we really have and one we can control; we must control the numbers of children being born if we are to stop the runaway growth of the human population.

**Table 2.9** *The effects of population control policies*

Many countries now encourage some kind of population control. A few of these are described in table 2.9.

Country	Way of reducing numbers born	Effect on population
China	In 1979 a policy was introduced which discouraged more than one child per family; an unwanted pregnancy is punished with a fine.	Population is still increasing but there has been a huge slowing of the rate of increase.
India	Only people with two or fewer children may serve in local government. Contraception has been introduced.	Population is still increasing, but rate of increase has been slowed.
Iran	Compulsory contraception courses for males and females before a marriage licence can be granted.	Rate of population increase has decreased from 4% in 1980 to 1.3% in 2008.
USA	Free contraception available as well as free sex education; priority is given to those who are poorest.	Population is stable and increasing only slightly.

**Activity 2.14: What should Ethiopia do?**

Read and discuss the measures taken by other countries to reduce birth rates, as shown in table 2.9. List the measures that you think should be taken in Ethiopia. Explain why you have chosen each measure.

At the moment Ethiopia has one of the highest birth rates in Africa, but there are some hopeful signs that this is changing. It is progressing through the demographic transition, and, as it does so, death rates and birth rates will fall as more resources become generally available.

In the meantime, it is essential that education regarding contraception is available to the people throughout Ethiopia. There are several methods of contraception available, but widespread use of condoms will have the most impact as they are the most easily available. They also give some limited protection against the transmission of HIV.

Fewer children will be needed, particularly in rural communities, if more of them live longer. Good health alongside education will help to reduce the rapid increase in population growth that characterises Ethiopia at the moment.

It is vital that the government makes available as many resources as possible to help local communities, particularly rural communities, with:

- sex education
- access to contraception
- general education to enable students to consider other options in their futures

All of these will help in reducing the rapid population growth rate. In addition, help with the following will improve general health, which is usually associated with lower reproduction rates:

- education about diet
- resources to improve the quantity and quality of crops grown and stock reared in rural communities

## Review questions

Choose the correct answer from A to D.

1. A population is:
  - A a group of one species in the same place at the same time
  - B a group of different species in the same place at the same time
  - C all the organisms of one species in the same place at the same time
  - D all the organisms of different species in the same place at the same time
2. Which of the following definitions best describes a habitat?
  - A the role of an organism within its surroundings
  - B the physical surroundings in which an organism lives
  - C the area where an organism lives and finds everything it needs – its home
  - D the number of organisms of a particular species living in an area
3. The sequence of phases in a population growth curve is:
  - A log – lag – stationary – decline
  - B lag – log – stationary – decline
  - C lag – log – decline – stationary
  - D log – lag – decline – stationary
4. The age pyramid in Figure 2.47 represents:
  - A an expanding population
  - B a static population
  - C a population in decline
  - D an unbalanced population

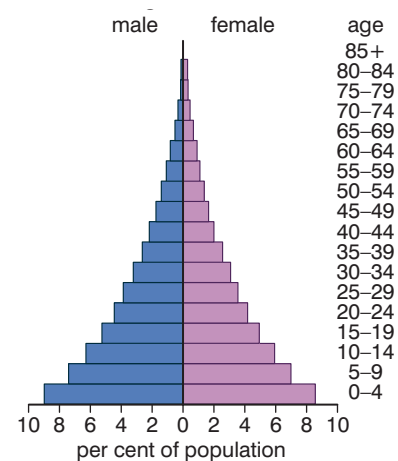


Figure 2.47

5. Inter-specific competition is:
  - A competition between members of different species in the same ecosystem
  - B competition between members of the same species in the same ecosystem
  - C competition between members of the same species in the same habitat
  - D competition between members of different species in the same habitat
6. The best description of the abiotic factors of a pond ecosystem is:
  - A the pond water and dissolved oxygen
  - B the pond water and all the dissolved substances
  - C the pond water, the dissolved substances and the mud at the bottom and sides of the pond
  - D the pond water, the dissolved substances, the mud at the bottom and sides of the pond and the air above the pond
7. In exponential growth, numbers increase:
  - A by the same amount in each successive time period
  - B by a decreasing amount in each successive time period
  - C by an increasing amount in each successive time period
  - D none of the above
8. The human population is currently:
  - A increasing at an increasing rate
  - B increasing at a steady rate
  - C increasing at a slowing rate
  - D decreasing
9. The carrying capacity of a population is:
  - A the maximum number the population can attain
  - B the maximum number that can be sustained by the environment
  - C the minimum level at which the population is still viable
  - D none of the above
10. Action that can be taken to reduce rapid population growth includes:
  - A reproductive (sex) education
  - B access to condoms
  - C improved resources for agriculture
  - D all of the above



## Summary

In this unit you have learnt that:

- Decomposers, including bacteria and fungi, feed saprobially to break down the dead remains of organisms, which releases mineral ions contained in organic molecules in the dead matter.
- In the carbon cycle:
  - carbon dioxide is removed from the air and fixed into organic molecules in photosynthesis
  - carbon dioxide is replaced in the air when any organism respire or when fossil fuels are burned
  - organic molecules are passed from animals to plants by feeding and assimilation
  - organic molecules are passed from animals and plants to decomposers by saprobial feeding on the dead remains of organisms
  - sometimes dead remains form fossil fuels; carbon dioxide is released when these are burned
- In the nitrogen cycle:
  - nitrates are absorbed from the soil by plants and used to make proteins
  - animals eat the plants and use the plant proteins to make animal protein
  - when the animals and plants die the proteins pass into the detritus; in addition, excretory products such as urea pass into detritus
  - decomposers release ammonium ions from nitrogen-containing organic molecules
  - nitrifying bacteria oxidise the ammonium ions to nitrates
  - denitrifying bacteria reduce nitrates to nitrogen gas
  - nitrogen-fixing bacteria reduce nitrogen gas to ammonium ions, either free in the soil or in root nodules of legumes
- In the phosphorus cycle:
  - phosphates are absorbed from the soil by plants and used to make organic molecules
  - animals eat the plants and make their own phosphorus-containing organic molecules
  - when the animals and plants die the organic molecules pass into the detritus
  - decomposers release phosphate ions from phosphorus-containing organic molecules
  - some phosphate ions become incorporated into rocks
  - the rocks may be mined and used to make fertilisers that are added to the soil

- In the sulphur cycle:
  - sulphates are absorbed from the soil by plants and used to make proteins
  - animals eat the plants and use the plant proteins to make animal protein
  - when the animals and plants die the proteins pass into the detritus
  - decomposers release hydrogen sulphide from sulphur-containing organic molecules; this is then oxidised to sulphates
- In the water cycle:
  - water evaporates from the oceans and falls as rain or snow over the land and sea
  - some water enters waterways and returns to the sea either directly or after having been used by humans
  - some water runs off the land
  - some water enters large underground aquifers
- Complex ecosystems develop from simpler ones in the process of succession.
- In a primary succession:
  - a hostile area is colonised by pioneer species
  - the pioneer species change the abiotic conditions and allow other species to colonise the area
  - the new species also change the abiotic conditions allowing another stage of colonisation
  - the different stages are called seres
- As more plant species colonise, they create more niches for other organisms.
- The most complex ecosystem to develop is the climax community.
- A secondary succession can occur when an existing ecosystem is destroyed.
- A biome is a geographically and climatically defined region with organisms which have similar ecological adaptations.
- Biomes may be terrestrial, marine or freshwater.
- The main factors in determining terrestrial biomes are temperature and precipitation.
- Biodiversity is the variability of living things; it includes their species diversity, genetic diversity and ecological diversity.
- Humans have reduced biodiversity in a number of ways including non-sustainable felling of forests and the introduction of large-scale agricultural practices.

- Ethiopia has a high biodiversity at the moment, but the biodiversity is threatened by:
  - deforestation or the burning of vegetation
  - commercial logging
  - subsistence farming
- A loss of biodiversity can lead to:
  - worsening health
  - increasing insecurity of food supply
  - increasing vulnerability
  - less freedom for choice and action
- Planting a tree can help to increase biodiversity.
- Two key activities in maintaining biodiversity are:
  - maintaining habitats
  - using resources in a sustainable way
- A population is all the individuals of a particular species in a particular habitat at a particular time.
- A habitat is an area where a population lives and finds the nutrients, water, living space and other essentials it needs to survive.
- An ecological niche describes the role of an organism within a habitat.
- The size of a population is affected by:
  - biotic factors – predation, disease-causing organisms, intra-specific and inter-specific competition for a resource (often food)
  - abiotic factors – factors of the physical environment, such as temperature, light intensity, concentration of oxygen or carbon dioxide, availability of water
- In intra-specific population, members of the same species compete for a resource; overuse of the resource can lead to a population crash.
- In inter-specific competition, members of different species compete for a resource; this usually leads to local extinction of the weakest competitor, although coexistence is possible if the two species do not use the resource in the same way.
- In arithmetic increase, numbers increase by a set amount in each time period.
- In exponential increase, numbers increase by an increasing amount in each time period.
- The four stages of a population growth curve are:
  - lag phase – population is low and stable as the population adapts to the new surroundings

- log phase – the adapted population increases rapidly due to abundant resources
- stationary phase – numbers are high and stable as deaths are matched by births; this is the carrying capacity for the population in that area
- decline phase – overuse of resources or accumulation of toxic waste products causes a decline in the population; if the resources recover, the population may also recover, otherwise it may decline to zero
- The stages of development of the human population of a country can be represented in the demographic transition as it changes from a pre-agricultural society to an industrial society and finally post-industrial society.
- Age pyramids show the percentage of males and females in each age group in a population.
- Expanding, stationary and contracting populations have different age pyramids.
- Rapid population growth can be controlled by:
  - contraception programmes
  - education about sex
  - better provision of resources to agriculture

## End of unit questions

- Name four compounds that contain carbon.
  - Draw a labelled diagram to describe the main stages of the carbon cycle.
- Explain the importance of nitrogen-fixing bacteria.
  - Explain the difference between nitrification and denitrification.
  - Describe how ammonification takes place.
- Figure 2.48 shows how a pond ecosystem can change over time through succession.
  - What name precisely describes this type of succession?
  - What would you expect to see happen if the process were allowed to continue?
  - Give three features that are common to all successions.
- Figure 2.49 shows a typical population growth curve.
  - Explain why the population does not increase:
    - during phase A
    - during phase C
  - Give two reasons for the decline during phase D.
  - Which phase corresponds most closely to the current rate of change of the human population? Explain why this is the case.

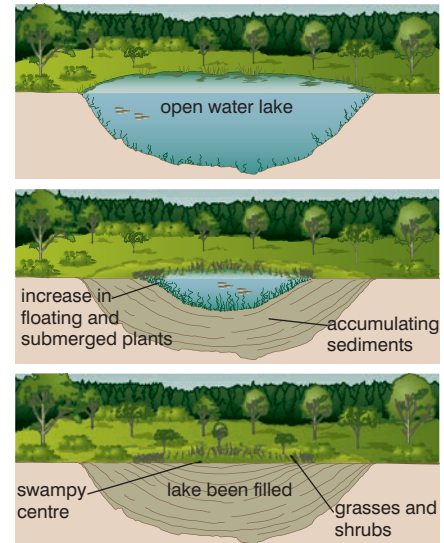


Figure 2.48

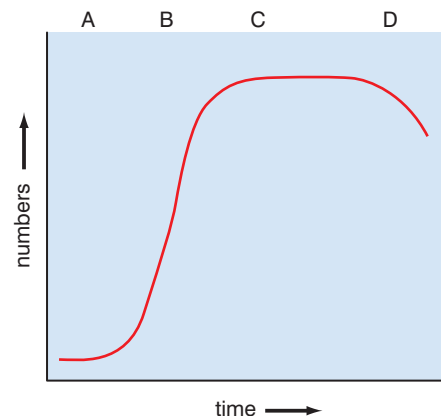


Figure 2.49

- Figure 2.50 shows potential changes in the biomes in South Africa as a result of climate change. Nama karoo is a kind of scrub biome, in between savannah and thorn forest.

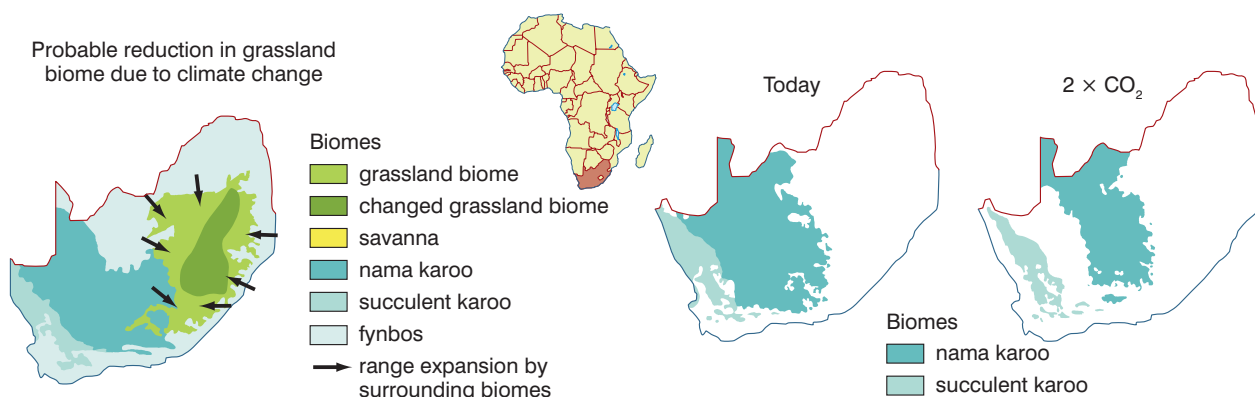


Figure 2.50

- What is a biome?
- Compare the biome richness of Ethiopia with that of South Africa.
- Describe, as fully as you can, the changes that are predicted to occur in the South African biomes.

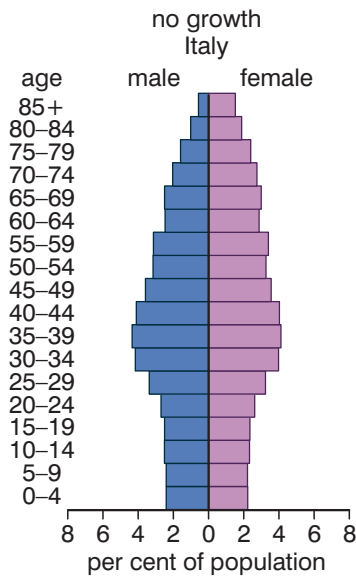


Figure 2.51

6. Figure 2.51 shows the age pyramid of a developed country.
  - a) Describe the evidence in the pyramid that suggests that women have a longer life expectancy than men.
  - b) Is this an expanding, static or shrinking population? Use evidence from the diagram to support your answer.
  - c) State three ways in which the population structure of a developing country would be different from this country.
7. Figure 2.52 shows the phosphorus cycle.

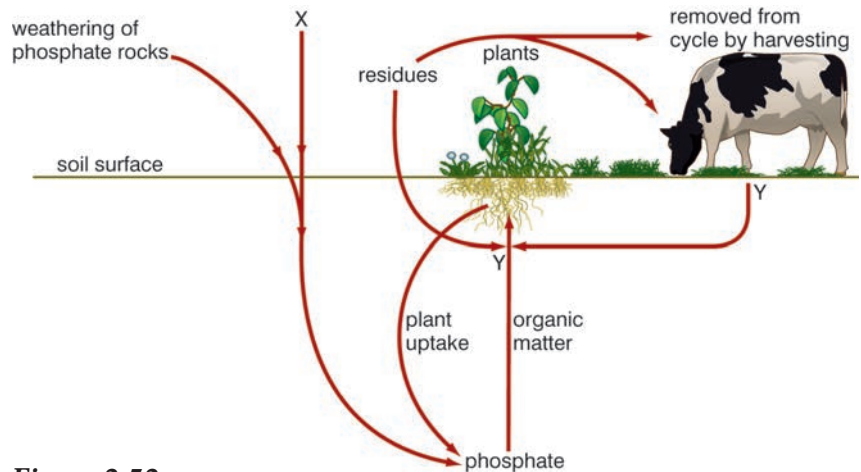
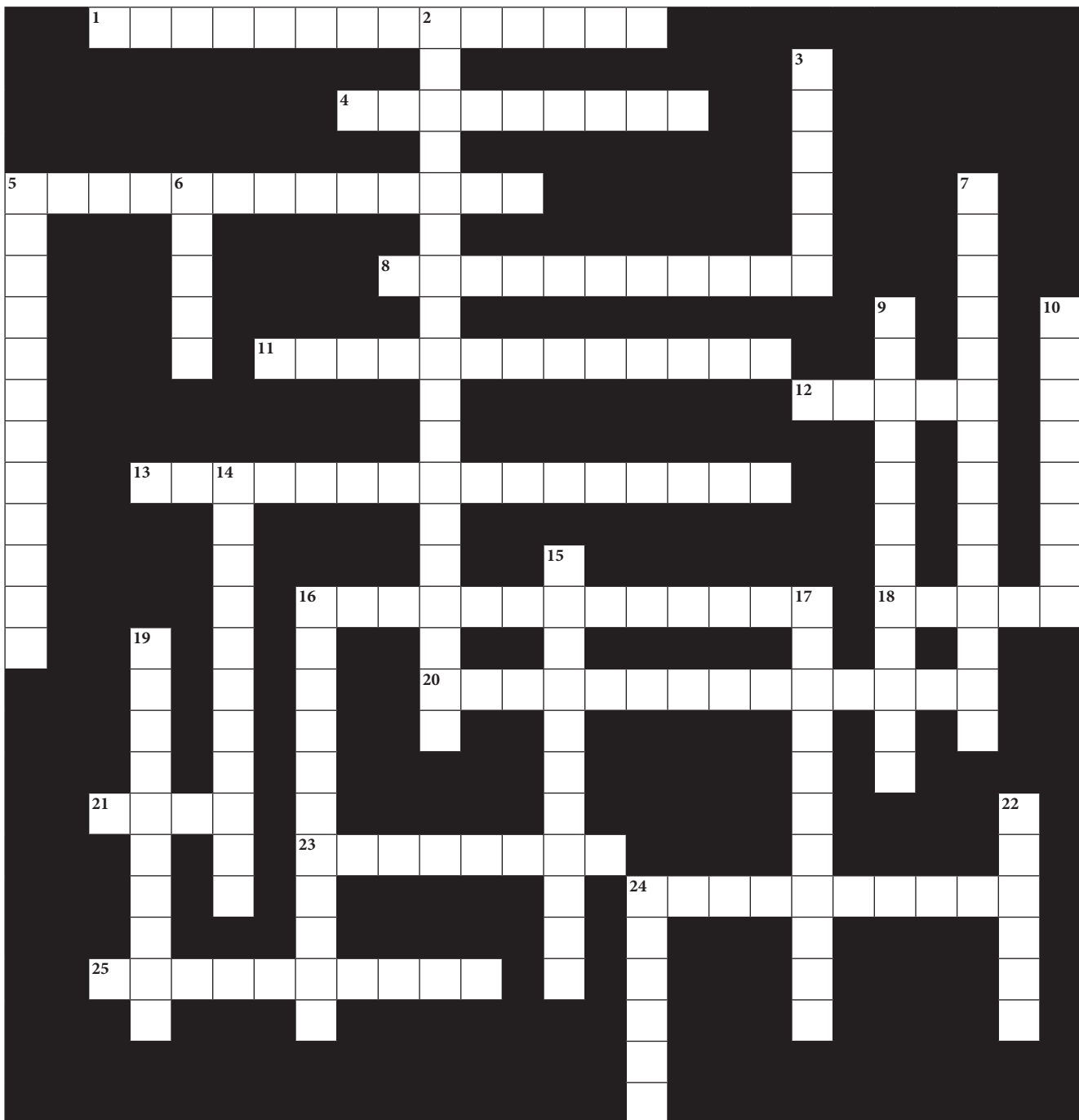


Figure 2.52

- a) Describe three ways in which living things use phosphorus.
  - b) (i) Describe what happens in process Y.  
(ii) Harvesting and process X are linked. Explain how.
  - c) When compared to the carbon cycle, describe two ways in which the phosphorus cycle is:
    - (i) similar
    - (ii) different
8. Write a short essay on biodiversity. You should include the following in your essay:
  - What we mean by biodiversity.
  - How we are damaging our biodiversity.
  - The effects of loss of biodiversity.
  - What we can do about it.

Copy the crossword puzzle below into your exercise book (or your teacher may give you a photocopy) and solve the numbered clues to complete it.



**Across**

1. The process in the carbon cycle that removes CO<sub>2</sub> from the air (14)
4. The layer at the surface of the Earth where life is found (9)
5. The practice of felling trees for human benefit (13)
8. The type of nutrition shown by decomposers (11)
11. This type of competition occurs between members of different species (13)

12. A geographical area with a specific climate and soil type and with specifically adapted animals and plants (5)
13. The sulphur-containing gas that smells of bad eggs and is released when organisms are decayed (8, 8)
16. The type of digestion that occurs outside cells (13)
18. Phosphates can enter the soil when ... are weathered (5)
20. The sulphur-containing gas that contributes to acid rain (7, 7)
21. One of the stages of a succession (4)
23. If this exceeds mortality, the size of a population will increase (8)
24. A process in the carbon cycle carried out by humans only, that adds CO<sub>2</sub> (10)
25. All the organisms of a particular species in a specific area (10)

**Down**

2. A biome that is warm, with thin soil and has many different animals and plants (8, 10)
3. Predation and disease are examples of this sort of factor that affects populations (6)
5. These bacteria reduce the amount of available nitrogen in a soil (12)
6. A reaction that involves reduction and oxidation (5)
7. Organisms that are the first stage in a primary succession (7, 7)
9. The species richness and abundance of an area is its ... (12)
10. We must preserve these in order to conserve endangered species (8)
14. These organisms decay dead matter (11)
15. A process in the carbon cycle carried out by all living things that adds CO<sub>2</sub> to the air (11)
16. The type of population growth in which the numbers in a population double in a set period of time (11)
17. Some nitrogen-fixing bacteria live in these (4, 7)
19. The process by which bare ground becomes a complex ecosystem (10)
22. A biome that is cold, dry with lichens and mosses that are fed on by migrating animals (6)
24. This type of community is the final and most complex stage of a succession (6)



Contents	
Section	Learning competencies
3.1 Genetic crosses (page 102)	<ul style="list-style-type: none"> <li>• Work out the outcomes of monohybrid crosses and dihybrid crosses.</li> <li>• Use the Punnett square to determine genetic crosses.</li> <li>• Determine genotypes and phenotypes formed in a genetic cross.</li> <li>• Explain the different types of dominance.</li> <li>• Describe the significance of the fact that not all genes show a straightforward dominant/recessive relationship between different alleles of the gene.</li> <li>• State that some genes have more than two alleles.</li> <li>• Describe the different stages of meiotic division.</li> <li>• Describe the significance of meiosis as both a source of variation through crossing over and independent assortment as well as a method of halving chromosome number in the gametes.</li> <li>• Describe how a knowledge of genetics is important in artificially producing new varieties of crops and stock animals through artificial cross-breeding and inbreeding.</li> <li>• Explain why fruit flies (<i>Drosophila melanogaster</i>) have been used in much genetic research.</li> <li>• Explain the genetic basis of gender determination and why it is that some characteristics are sex-linked, sex-influenced or sex-limited.</li> </ul>
3.2 Molecular genetics (page 128)	<ul style="list-style-type: none"> <li>• Describe the structure of a chromosome.</li> <li>• Describe in detail the structure of the DNA molecule.</li> <li>• Name the four nucleotides that build up the DNA molecule.</li> <li>• Construct a model of DNA showing the base pair between complementary nucleotides.</li> <li>• Describe the semi-conservative replication of DNA.</li> <li>• Describe the significance of some of the uses of gene technology in forensic science (such as genetic fingerprinting).</li> <li>• Describe how genetic fingerprints are produced.</li> <li>• Define and give examples of cloning.</li> <li>• Understand that genes can be cloned and explain in outline how this is achieved.</li> <li>• Describe, in outline, the procedures involved in genetic engineering and appreciate that whilst there are many advantages that result from the process, there are also some ethical concerns about some of the procedures.</li> </ul>

Contents	
Section	Learning competencies
3.3 Protein synthesis (page 142)	<ul style="list-style-type: none"> <li>Describe how the flow of information in a cell starts from the code on DNA and ends with proteins being synthesised.</li> <li>Understand the nature of the genetic code.</li> <li>Describe the roles of DNA, mRNA, tRNA and ribosomes in protein synthesis and understand the processes of transcription, translation and gene expression.</li> <li>Understand that protein synthesis depends on having a supply of amino acids which, in animals, come from the food they eat.</li> <li>Understand the different roles proteins have in cells and in the body.</li> </ul>
3.4 Mutations (page 152)	<ul style="list-style-type: none"> <li>Explain what is meant by the term mutation.</li> <li>Describe some of the different types of mutations.</li> <li>Describe and explain some of the causes of mutations.</li> <li>State the spontaneity of a mutation.</li> <li>Describe and explain some of the consequences of mutations.</li> <li>Give examples of inheritable mutations.</li> </ul>

### 3.1 Genetic crosses

#### Activity 3.1

Humans have several genetic traits which are inherited through single genes. These include dangly or attached earlobes, straight or curved thumbs and dimples or no dimples. Carry out a survey of people you know (in class, at home, in your family and friends) and make bar charts to compare the numbers of people who have the different versions of these genetic traits. The more people you ask, the more valid your results will be.

By the end of this section you should be able to:

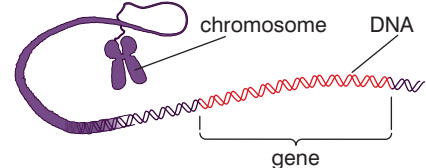
- Work out the outcomes of monohybrid crosses and dihybrid crosses.
- Use the Punnett square to determine genetic crosses.
- Determine genotypes and phenotypes formed in a genetic cross.
- Explain the different types of dominance.
- Describe the significance of the fact that not all genes show a straightforward dominant/recessive relationship between different alleles of the gene.
- State that some genes have more than two alleles.
- Describe the different stages of meiotic division.
- Describe the significance of meiosis as both a source of variation through crossing over and independent assortment as well as a method of halving chromosome number in the gametes.

- Describe how a knowledge of genetics is important in artificially producing new varieties of crops and stock animals through artificial cross-breeding and inbreeding.
- Explain why fruit flies (*Drosophila melanogaster*) have been used in much genetic research.
- Explain the genetic basis of gender determination and why it is that some characteristics are sex-linked, sex-influenced or sex-limited.

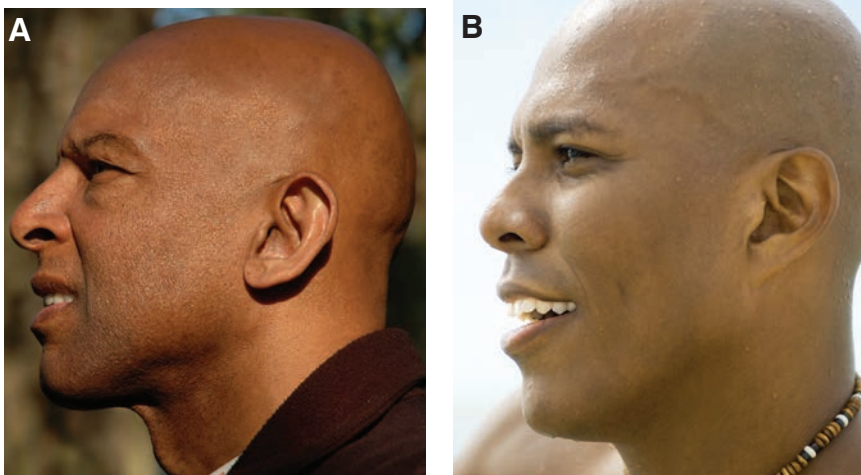
### What is the relationship between chromosomes, genes, alleles and characteristics of an organism?

In grade 11, unit 2, we learned about biological molecules. One of these was the molecule of inheritance – DNA. We shall be learning in more detail how this molecule is able to pass on our features or traits in section 3.2. For now, however, we need to revise a little of the structure of the molecule and where it is situated in cells. Figure 3.1 shows how chromosomes, **genes** and DNA are related.

In grade 11, unit 4, we learned that chromosomes are found in the nucleus of a cell and are made from the DNA, which is bound with **histone** proteins to form the chromosomes.



**Figure 3.1** Chromosomes, genes and DNA



**Figure 3.2** Attached and unattached earlobes.

A gene is a section of DNA (and therefore a section of a **chromosome**) that determines a particular feature, for example, earlobe attachment in humans. Whether or not your earlobes hang free (figure 3.2A) or are attached (figure 3.2B) is determined by a single gene. However, there are two versions of this gene. One version says 'be attached' and the other says 'don't be attached – be free'.

Different versions of the same gene are called **alleles**.

Because humans reproduce sexually, we receive half of our chromosomes from one parent and half from the other. And the two sets are very similar. In our cells we have 46 chromosomes; 23

#### KEY WORDS

**gene** a section of DNA that determines a specific feature

**histone** the core of a chromosome around which the chromosome's DNA is wrapped

**chromosome** a long strand of DNA on which a large number of genes is stored

**allele** a version of a gene that determines a particular trait

**KEY WORDS**

**homologous pairs** the chromosomes in a eukaryotic cell usually come in pairs called homologous pairs. Each of the chromosomes in a homologous pair have corresponding genes that together determine the same trait

**locus** (plural **loci**) the position of a particular gene on a chromosome

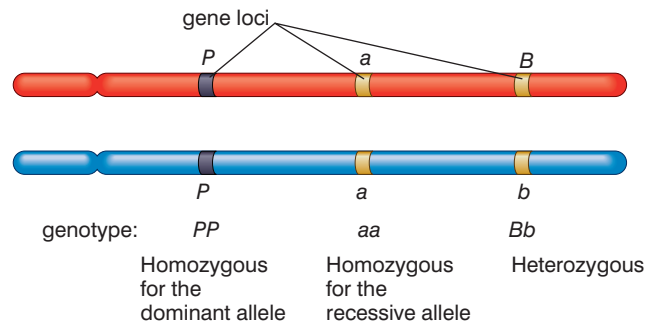
**homozygous** an organism is homozygous for a particular gene if it has the same allele for that gene on each of the chromosomes in the homologous pair

**heterozygous** an organism is heterozygous for a particular gene if it has different alleles for that gene on each of the chromosomes in the relevant homologous pair

**genotype** a genotype describes the pair of alleles for a particular gene possessed by a organism

**phenotype** a phenotype describes the trait or traits determined by a particular genotype

are paternal in origin (came from our fathers) and 23 are maternal in origin (came from our mothers). And when they get together, they form pairs called **homologous pairs**. These homologous pairs have genes controlling the same features in the same position – or **locus** – on the chromosome. However, the alleles may not be the same. Figure 3.3 shows the loci of three genes on a pair of homologous chromosomes.



**Figure 3.3** Loci of alleles on homologous chromosomes

Gene 1 has two alleles P and P. Both chromosomes have the dominant P allele (we say that the individual is **homozygous** for the dominant allele).

Gene 2 has two alleles, a and a. Both chromosomes have the recessive allele a (homozygous for the recessive allele).

Gene 3 has alleles B and b. One chromosome has the dominant allele, B, whilst the other has the recessive allele, b. We say that the individual is **heterozygous** for this particular gene.

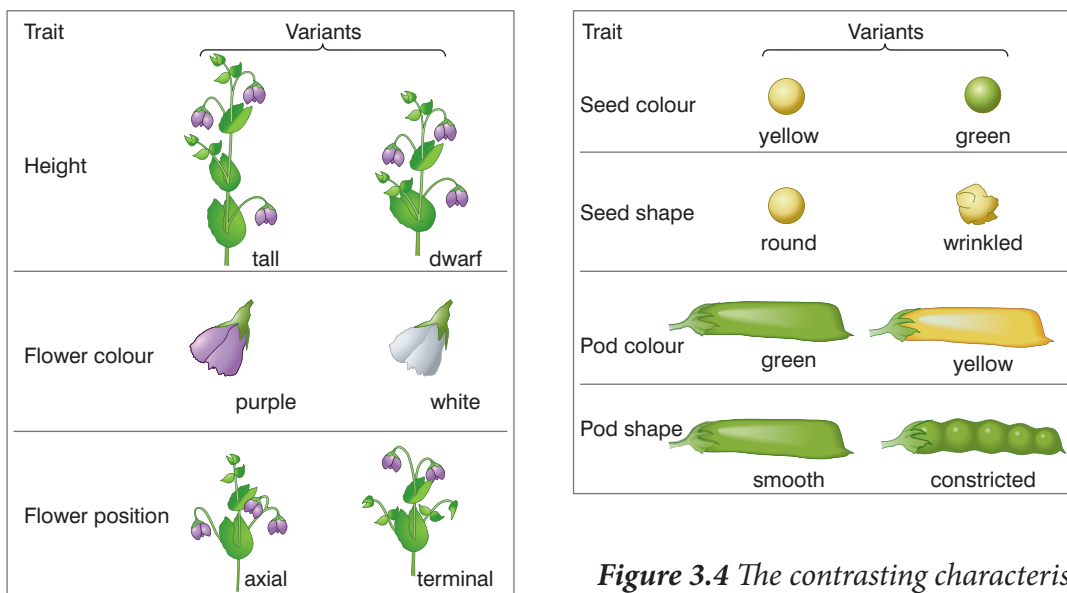
The alleles of a particular gene possessed by an individual are its **genotype** (for that feature). The actual result of that genotype (whether or not the earlobes are attached, for example) is the **phenotype** (for that feature). If you know the genotypes of two parents, you can make predictions about the type and proportions of offspring they will have in relation to a particular feature. You can also throw that into reverse: if you know proportions of offspring showing certain versions of a feature, you can often work out the genotypes of the parents. Just how we do this, you will learn in the next part of this section.

**How do we predict ratios in a monohybrid cross?**

First, let us make clear what we are talking about. A monohybrid cross is a genetic cross or breeding situation that relates to just one trait or feature. The ‘father’ of genetics, the man who discovered the rules by which genes are inherited, was the Austrian monk Gregor Mendel. Living and experimenting in a monastery in Brno, Mendel experimented with pea plants and was able to deduce the rules of inheritance from his results.

He noticed that pea plants exhibited ‘contrasting characteristics’. For example, the plants were either tall or short, had purple flowers

or white flowers. Now not all tall pea plants are exactly the same height, neither are all dwarf ones. But you wouldn't mistake a tall plant for a dwarf one. And obviously, you wouldn't mistake a purple-flowered plant for a white-flowered one. This was the key that enabled Mendel to experiment successfully – there were never any medium-height pea plants or plants with pale purple flowers. Figure 3.4 shows the seven contrasting characteristics that Mendel used in his experiments.

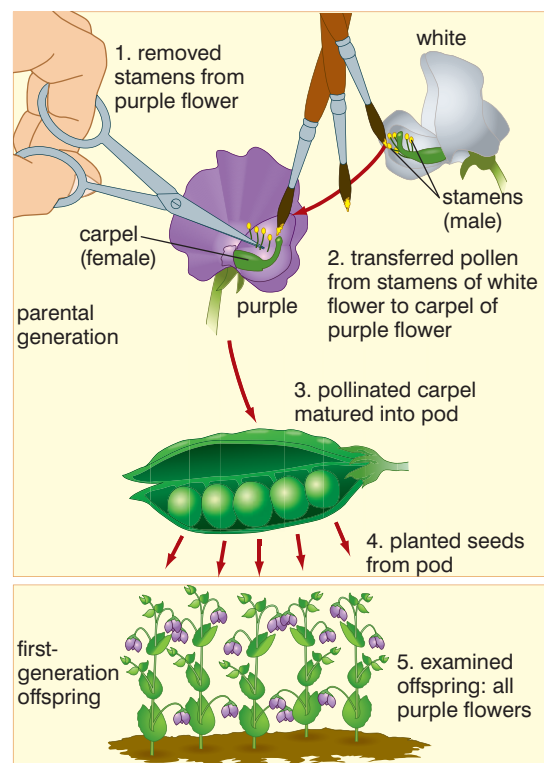


**Figure 3.4** The contrasting characteristics of pea plants used by Mendel in his experiments

### How did he do it?

Mendel was very methodical. His starting point was to wonder what would happen if he cross-bred two pea plants with contrasting features – for example, plants with purple flowers and plants with white flowers. Before he carried out any breeding experiments, he self-pollinated the plants for several generations, and eventually used plants from a 'breeding line' that had contained only purple-flowered plants or white-flowered plants. These he called 'true-breeding' plants. He then cross-bred them in the following way. We will use flower colour as our example, but he used the same procedure for all the contrasting characteristics.

1. He removed stamens from the flowers of the purple-flowered plant (so that these flowers could not pollinate themselves).
2. He used a paintbrush to transfer pollen from the flowers of the white-flowered plant to the carpel of the purple flowers.
3. This pollinated carpel then produced a pea pod containing several pea seeds.
4. He collected and grew all the seeds from all the pods.
5. When the plants were mature, he noted the colour of their flowers.



**Figure 3.5** Mendel's technique

**KEY WORDS**

**F<sub>1</sub>/F<sub>2</sub> (first/second filials)**  
*when organisms with different traits are cross-bred, F<sub>1</sub> refers to the offspring from the original organisms, and F<sub>2</sub> refers to the offspring of the F<sub>1</sub> organisms*

**trait** *a feature of an organism determined by its genes*

**dominant allele** *a dominant allele is the allele expressed in a heterozygous organism*

**recessive allele** *a recessive allele is only expressed in a homozygous organism*

Mendel also carried out reciprocal crosses. In this case he also pollinated white-flowered plants with pollen from purple-flowered plants.

In the above cross, all the offspring (which we call the **F<sub>1</sub>** or **first filial** generation) have purple flowers. Mendel then allowed these purple-flowered plants to self-pollinate themselves. In the next generation (the **F<sub>2</sub>** or **second filial** generation) he found a ratio of very nearly three purple-flowered plants for every one white-flowered plant. This pattern repeated itself in all of his experiments. In each case he:

- crossed pure-breeding plants with contrasting characteristics
- found that only one of the characteristics appeared in the F<sub>1</sub> generation (always the same one – always purple flowers, for example, never white), and
- found a ratio of 3:1 in the F<sub>2</sub> generation (always 3 of the one that had appeared in the F<sub>1</sub> and 1 of the one that hadn't).

It was this pattern that led Mendel to formulate his laws and to coin the terms dominant and recessive. He used the term dominant to describe the allele that determined the **trait** that appeared in the F<sub>1</sub> and the term recessive to describe the allele that determined the trait that did not appear in the F<sub>1</sub>. Table 3.1 summarises the results for all Mendel's breeding experiments.

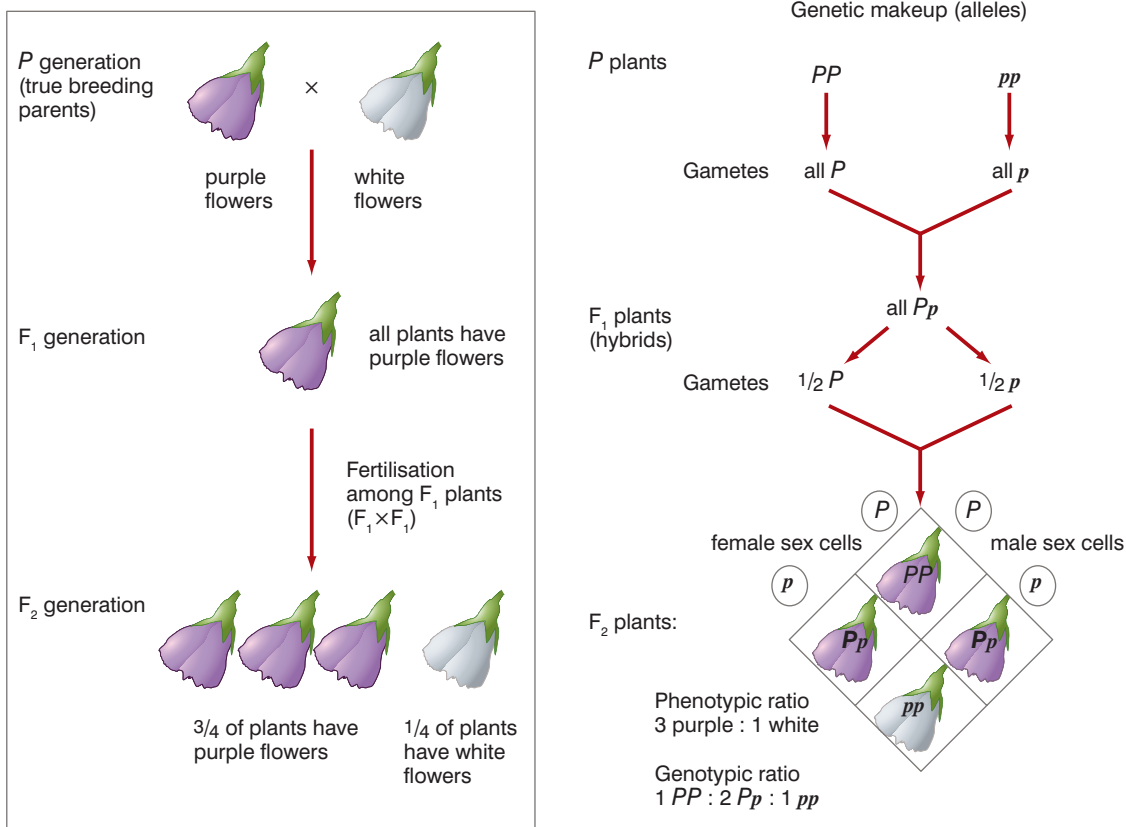
**Table 3.1 Mendel's results**

Character	Dominant trait	×	Recessive trait	F <sub>2</sub> generation	Ratio
				dominant recessive	
Flower colour	purple	×	white	705:224	3.15:1
Flower position	axial	×	terminal	651:207	3.14:1
Seed colour	yellow	×	green	6022:2001	3.01:1
Seed shape	round	×	wrinkled	5474:1850	2.96:1
Pod shape	inflated	×	constricted	882:299	2.95:1
Pod colour	green	×	yellow	428:152	2.82:1
Stem length	tall	×	dwarf	787:277	2.84:1

The overall ratio for the F<sub>2</sub> generation is 2.99:1. This could hardly be nearer to 3:1 and, indeed, caused some biologists to accuse him of falsifying his results. However, most believe that he was just an exceptionally meticulous experimenter.

Mendel explained these results in the following way:

1. Every trait (like flower colour, or seed shape, or seed colour) is controlled by two 'heritable factors' – these are what we now call genes. The heritable factors (genes) may take different forms (alleles).
2. If the two alleles in an individual are different, one is **dominant** (will be expressed in the organism's appearance or physiology) and one is **recessive** (cannot be expressed unless the individual has two copies of the recessive allele). Dominant traits mask the appearance of recessive traits.
3. The only physical link between the generations is the gametes or sex cells. These must pass the genes from one generation to the next.
4. The heritable factors (alleles) separate when the gametes (sex cells) are formed; each gamete therefore contains only one allele controlling the trait. This is Mendel's 'law of segregation'. He also stated that the gametes (sex cells) fuse randomly at fertilisation.



**Figure 3.6** The genetic basis of Mendel's results from crosses between purple-flowered pea plants and white-flowered pea plants

After further studies and experiments, Mendel also formulated another law called the 'law of independent assortment'. This law states that the inheritance of one trait is independent of the inheritance of another. That is, the alleles of one pair segregate independently of the alleles of another pair controlling a different feature. Whilst this was true for the traits that Mendel studied in pea plants and is true for many traits in many other organisms, we now know that it is not always the case, as we shall see when we look at the phenomenon of linkage.

If we return to our example of the cross between purple-flowered plants and white-flowered plants, we can now explain what is happening in terms of segregation of alleles, random fertilisation and the concepts of dominant and recessive alleles.

In the genetic diagram in Figure 3.6, the symbol **P** represents the dominant allele for purple flowers and **p** represents the recessive allele for white flowers.

Both parents are homozygous.

Alleles segregate and gametes contain only one of the pair.

All F<sub>1</sub> are heterozygous, with purple flowers as **P** is dominant.

Alleles segregate and half of the gametes receive **P** and half **p**.

The gametes fuse at random in fertilisation. All the combinations of gametes are shown in this Punnett square. This represents the possible genotypes of the offspring and the ratio in which they will occur.

### Activity 3.2

Make a simple model – for example using beads or clay – to explain how a genetic cross works.

**See if you can solve the following**

Draw genetic diagrams to show the offspring that would result from the following crosses. Check table 3.1 to see which trait is dominant and which is recessive.

- heterozygous purple-flowered plants and white-flowered plants
- two white-flowered plants
- two heterozygous tall plants
- a heterozygous green-podded plant and a yellow-podded plant

You will need to make up your own symbols to represent the alleles.

So, if we know the genotypes of parents, we can produce genetic diagrams like the one above to work out the possible genotypes of their offspring and the proportions in which they will occur.

**How can parents showing one version of a feature have children with the other version?**

Let's stick with the gene for earlobes. It has two alleles – free earlobes and attached earlobes. Everyone has two alleles for this feature in all their cells (except the sex cells). A person could have:

- two attached earlobe alleles per cell (homozygous for the recessive allele)
- two free earlobe alleles per cell (homozygous for the dominant allele)
- one attached allele and one free earlobe allele per cell (heterozygous)

We can represent this process diagrammatically. If we use symbols for the different alleles:

**E** to represent the dominant allele for free earlobes  
**e** to represent the recessive allele for attached earlobes.

Suppose a man homozygous for free earlobes and a woman homozygous for attached earlobes have a child. The possible offspring are shown in Figure 3.7.

*Figure 3.7 The offspring of parents homozygous for free and attached earlobes, respectively*

		male sex cells	
		E	e
		(1/2)	(1/2)
female sex cells	E	EE	Ee
	(1/2)	(1/4)	(1/4)
e	Ee	ee	
(1/2)	(1/4)	(1/4)	

*Figure 3.8 The offspring of parents both heterozygous for free earlobes*

**KEY WORD**

**back cross/test cross**  
*an organism showing the dominant trait is bred with one showing the recessive trait. The results allow determination of whether the original organism showing this dominant trait was homozygous or heterozygous*

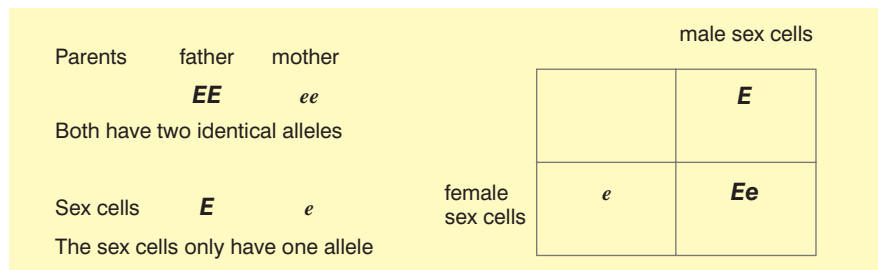


Figure 3.8 shows the outcome if both parents had had free earlobes with the genotype **Ee**.

We would expect three out of four children to have free earlobes and one out of four to have attached earlobes – a ratio of 3:1. Put another way there is a 75% or  $\frac{3}{4}$  probability that any particular child will have free earlobes and a 25% or  $\frac{1}{4}$  probability that the child will have attached earlobes.

**Remember this ratio ...**

It occurs in all organisms where two heterozygotes cross-breed.

So now we can answer our question 'how can parents showing one version of a feature have children with the other version?'. If both the parents show the feature determined by the *dominant* allele, but are *heterozygous*, they can produce children that show the feature determined by the recessive allele.

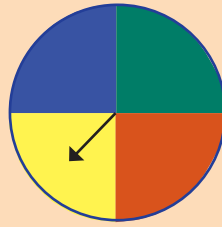
**Remember this too ...**

It is an important idea in solving genetic problems.



### Activity 3.3: Probability

Make a spinner with four colours like the one opposite.



When you spin it, it must land on one of the four colours. There is an equal probability that it will land on each of the colours. Each time, there are the same four possible outcomes, and one of them must happen, so every time there is a probability of 1 in 4, 0.25 or 25%, that it will land on each colour.

Now, you will investigate the number of events on how close the predicted probability matches reality!

Spin the spinner 12 times, record the results and work out the actual percentage occurrence for each. This is found by

$$\frac{\text{number of occurrences of a particular colour}}{\text{total number of spins}} \times 100$$

Record your results in a table like the one below.

Now repeat for 24, 36, 48 and 60 spins.

Number of spins	Percentage occurrence of:			
	Yellow	Blue	Red	Green
12				
24				
36				
48				
60				

How does the percentage occurrence match the predicted 25% as the number of spins changes?

### How could you find out if an organism showing the trait determined by a dominant allele is homozygous or heterozygous?

After all, all tall pea plants are tall and all unattached earlobes are unattached. It makes no difference to the appearance whether the organism is homozygous or heterozygous. The only possible way is to carry out a breeding experiment. However, this is not possible with humans, so we must look at any children they may have, or perhaps gain clues from their parents.

But first, let's look at the breeding experiment. The particular experiment to find out if an organism is homozygous or heterozygous for a dominant trait is called the **test cross** or the **back cross**. Let's again use the flower colour in pea plants as our example.

### DID YOU KNOW?

#### Why ratios don't always work out in the real world

What genetic diagrams show are *probabilities* that a certain genotype or phenotype will be produced. For instance, in the cross between two heterozygotes we *predict* that one quarter, 25%, will be homozygous recessive and will show the feature determined by the recessive allele. But a moment's thought will make you realise that it is only a prediction and may not be realised in any particular situation.

You might *predict* that with any toss of a coin there is a 50% chance of the coin landing head side up and if you tossed a coin ten times you would *predict* five heads and five tails. However, if you actually did it, you could easily get seven heads and three tails or four heads and six tails. But if ten people tossed a coin ten times, it would probably come close to 50 heads and 50 tails and even closer to 500 heads and 500 tails if one hundred people tossed a coin ten times.

Predicted ratios from genetic diagrams are only likely to be realised with large numbers of offspring. When the numbers are small, the laws of chance have a disproportionate effect.

**Remember ...**

When fertilisation occurs, any type of male sex cell could fertilise any type of female sex cell; it is a random process. Again, we work out the possible genotypes in the children by drawing a **Punnett square**.

**Activity 3.4: Seed counting**

In maize (sweetcorn) several features of the seeds on the cob are determined by single genes with dominant and recessive alleles. For example, the allele for purple seeds is dominant to that for yellow seeds.



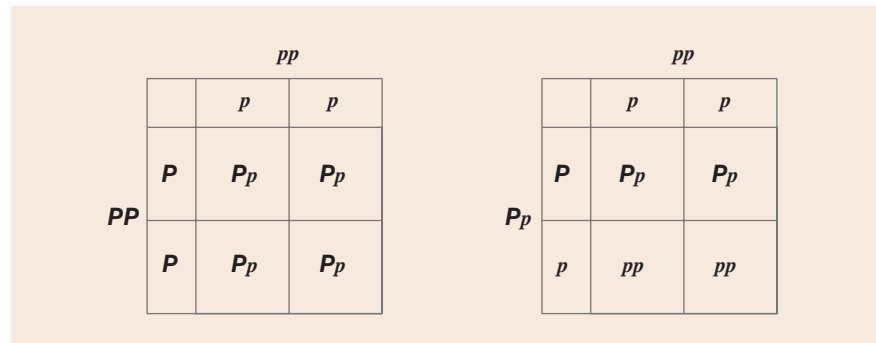
If two plants that are heterozygous for purple seeds are cross-bred, they will produce corn cobs with purple seeds and yellow seeds.

Count the number of purple seeds and yellow seeds on this maize fruit (cob).

What is the ratio of purple seeds to yellow seeds?

Is this what you would expect from the cross described above?

If we breed the purple-flowered plant with a plant whose genotype is definitely known, we can make predictions about the outcome. This can only be a white-flowered plant, which must have two recessive white alleles. There are then two possible outcomes. These are shown in in Figure 3.9.



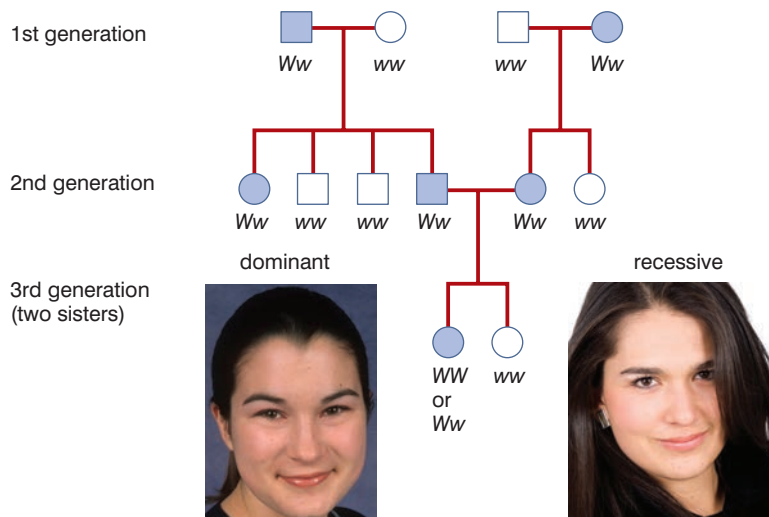
**Figure 3.9** Possible outcomes from a test cross

So, if we were to carry out the cross and find that any of the offspring had white flowers, we could be certain that the original purple parent was heterozygous. We know this because any white-flowered offspring would need to inherit two recessive ‘white’ alleles – one from each parent. If all the offspring were purple-flowered, we could be *almost* certain that the purple-flowered plant was homozygous. But because predicted ratios aren’t always met in the real world, we couldn’t be *absolutely* certain.

**How can we tell if an allele is dominant or recessive?**

This, again, requires us to look at offspring resulting from a particular cross. Sometimes information is given in a genetic pedigree. Figure 3.10 shows a genetic pedigree of a family over three generations for the trait of ‘widow’s peak’. In this pedigree:

- squares show males, circles females
- shaded symbols are ‘affected’ (have widow’s peak)
- W – dominant allele for widow’s peak
- w – recessive allele for no widow’s peak
- a horizontal line between two individuals represents a marriage
- vertical lines show parents/children



**Figure 3.10** A genetic pedigree for widow's peak

In this example, all the genotypes are shown, but it is possible to work out genotypes from a pedigree. Look at the sisters in the third generation. Their parents both had widow's peak, but one of the sisters doesn't. Even if you weren't told which was dominant, you could use what we learned in the previous section to work it out. The only way two parents showing one feature (the sisters' parents) can have children showing the alternate feature (the sister with no widow's peak) is if the parents are heterozygous. So they are heterozygous – they have both alleles. But they have widow's peak. This must mean that the widow's peak allele is dominant.

**Activity 3.5: How to work out genotypes of individuals in a pedigree**

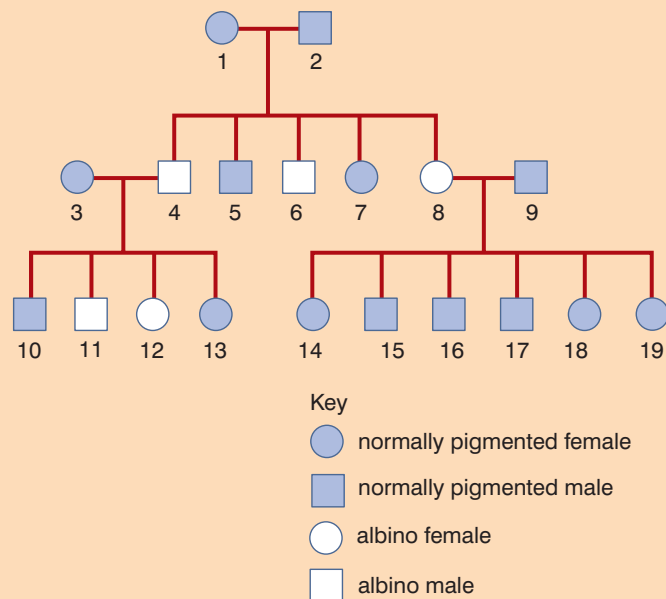
Look at figure 3.11, which is a pedigree showing the inheritance of albinism over three generations in a family.

In this activity we will use:

A to represent the allele for normal pigmentation

a to represent the allele for albinism

- How does the relationship between individuals 1, 2 and 6 prove that the allele for normal pigmentation is dominant over the allele for albinism?
- Why must the genotypes of all the individuals with albinism be aa?
- From where have the people with albinism inherited each of the a alleles?
- What allele will each of their children inherit from the individuals with albinism?
- What are the genotypes of individuals 3 and 17?



**Figure 3.11** A pedigree for albinism

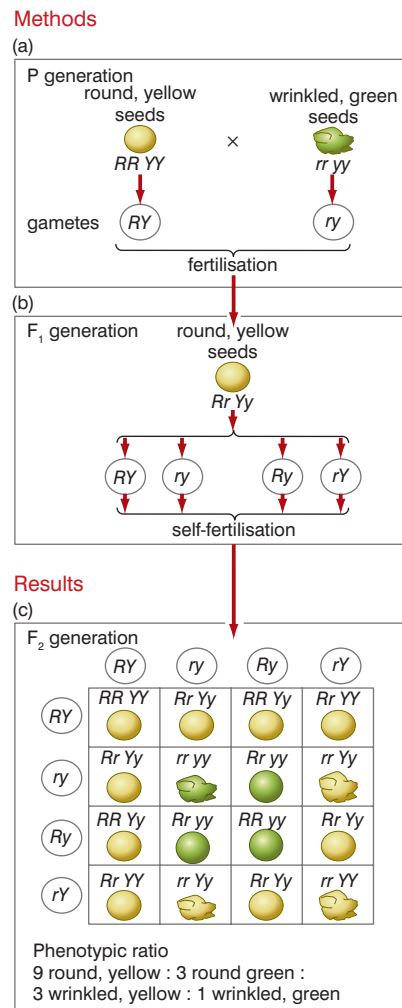


Figure 3.12 A dihybrid cross

What patterns do we get if we consider the inheritance of two genes at the same time?

This is known as dihybrid inheritance. When Mendel considered the inheritance of two characteristics at the same time, he followed essentially the same procedure as with his monohybrid experiments.

In one investigation, he bred plants that were homozygous for round, yellow seeds with plants homozygous for wrinkled, green seeds.

All the F<sub>1</sub> plants had round seeds which were yellow, showing that these alleles were dominant over the wrinkled and green alleles.

He then allowed these plants to self-fertilise themselves. In the F<sub>2</sub> generation, the other two features re-appeared, but in new combinations.

The four phenotypes that appeared in the F<sub>2</sub> and their proportions were:

- round and yellow 9
- round and green 3
- wrinkled and yellow 3
- wrinkled and green 1

Figure 3.12 shows how the alleles are passed from one generation to the next to bring about this result.

The behaviour of the alleles in gamete formation illustrates Mendel’s law of independent assortment.

The F<sub>1</sub> plants produce gametes containing an allele for each feature. But they are not linked in any way. When a gamete is formed containing an R allele, there is a 50% chance that it will also contain a Y or a y. This results in the four different types of gametes formed by the heterozygotes and the 16 possible combinations (some of them the same) in the Punnett square, giving the 9:3:3:1 ratio. Remember this ratio; it is always found in a dihybrid cross where the parents are heterozygous for both traits. Also, if you have to construct a Punnett square for a dihybrid cross, always write both sets of gamete genotypes in the sequence (let’s use alleles A and a with B and b) AB, Ab, aB, ab. This will then place the different genotypes in the same location in the square every time. Just think in triangles!

The nine individuals with both dominant alleles form a big triangle and are represented in blue. The three with the first dominant allele only (in our case, A) form a triangle represented in green. Those with the second dominant allele only (B) form a small triangle, shown in pink, and, finally, those with two recessive alleles are tucked away in the bottom right-hand corner. This is illustrated in figure 3.13.

	AB	Ab	aB	ab
AB	AABB	AABb	AaBB	AaBb
Ab	AABb	AAbb	AaBb	Aabb
aB	AaBB	AaBb	aaBB	aaBb
ab	AaBb	Aabb	aaBb	aabb

Figure 3.13 How to lay out a Punnett square for a dihybrid cross

### Is there a dihybrid test cross procedure?

There most certainly is! To discover the genotype of a plant whose phenotype shows both dominant features (we will stick with round seeds and yellow seed colour as our example), again a breeding experiment must be carried out. There are more possibilities than in monohybrid inheritance. The plant could be:

- homozygous for both features – **RRYY**
- heterozygous for both features – **RrYy**
- heterozygous for one feature but not the other – **RRYy** or **RrYY**

Following breeding with a double recessive type (rryy) there are the following possible outcomes:

- If the plants produced show all four possible phenotypes, the original was heterozygous for both features.
- If the plants produced all had round, yellow seeds, the original was homozygous for both features.
- If the plants produced all had round seeds but some had green and some had yellow seeds, the original was heterozygous for seed colour only.
- If the plants produced all have yellow seeds but some are round and some wrinkled, the original was heterozygous for seed shape only.

### Are alleles always simply dominant or recessive?

The short answer to this is no. Sometimes alleles are **codominant**; the two alleles of a gene are both equally dominant and so, in the heterozygote, both are expressed. An example of this is found in the flower colour of snapdragons. This is controlled by a single gene with two alleles:

- **R** – determines red-coloured petals
- **r** – determines white-coloured petals

The possible genotypes are:

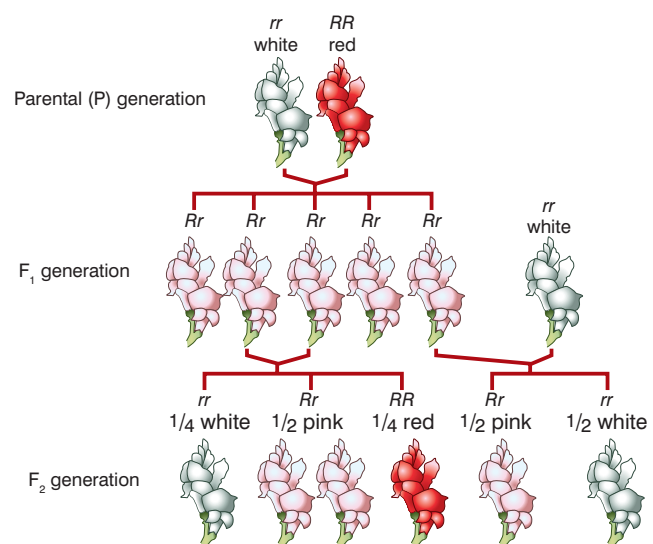
- **RR** – plants with red flowers
- **rr** – plants with white flowers
- **Rr** – plants with pink flowers; both alleles still express themselves and some red pigment and some white pigment is produced, resulting in pink flowers

If a red-flowered plant and a white-flowered plant are cross-bred, all the offspring will be heterozygous and have pink flowers. If two heterozygotes are crossed, the same genotype ratio (1:2:1) is obtained as with any monohybrid cross, but instead of a 3:1 phenotype ratio, this is also 1:2:1 (1 red:2 pink:1 white).

This is shown in figure 3.14.

#### KEY WORD

**codominant or incomplete dominant alleles** the pattern of inheritance where both alleles of a gene are equally expressed and determine which trait occurs in a heterozygous organism



**Figure 3.14** Codominance in snapdragon flower colour

**DID YOU KNOW?**

Although the gene may have more than two alleles, because they are alleles of the same gene, **any individual will still only have a maximum of two of the alleles.**

This is because the different alleles are found at the same locus (position) on homologous chromosomes. Because there are only two copies of each chromosome, the person can only have two alleles of the gene.

**Are there always two alleles of a gene?**

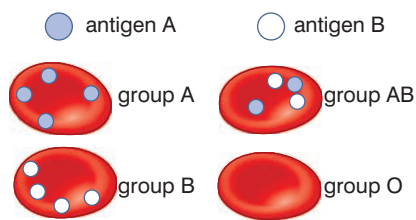
Again, the short answer is no. Some genes have more than two alleles, and then the pattern of inheritance is a little more complex. We call this situation multiple allele inheritance. However, the basic rules are just the same – alleles can be dominant or recessive or codominant.

An example of multiple allele inheritance occurs in the inheritance of the ABO blood groups. This is an interesting example as it also involves codominance. In the ABO blood grouping system, there are four blood groups, determined by the presence or absence of two antigens (A and B) on the surface of the red blood cells. Figure 3.15 illustrates this.

There are three alleles involved in the inheritance of these blood groups:

- $I^A$ , which determines the production of the A antigen
- $I^B$ , which determines the production of the B antigen
- $I^O$ , which determines that neither antigen is produced

Alleles  $I^A$  and  $I^B$  are codominant, but  $I^O$  is recessive to both. The possible genotypes and phenotypes (blood groups) are shown below.



**Figure 3.15** The ABO blood groups

Genotype	Blood group
$I^A I^A, I^A I^O$	A
$I^B I^B, I^B I^O$	B
$I^A I^B$	AB
$I^O I^O$	O

It is possible for two parents, with blood groups A and B, to have four children, each with a different blood group! Figure 3.16 shows how:

		male sex cells	
		$I^A$ (1/2)	$I^O$ (1/2)
female sex cells	$I^B$ (1/2)	$I^A I^B$ (1/4)	$I^B I^O$ (1/4)
	$I^O$ (1/2)	$I^A I^O$ (1/4)	$I^O I^O$ (1/4)

**Figure 3.16** How the four offspring of parents with blood groups A and B can all have different blood groups

	Father	Mother	
Parents	$I^A I^O$	$I^B I^O$	Both are heterozygous, but for different blood groups.
Sex cells	$I^A$ or $I^O$	$I^B$ or $I^O$	Parents can make two types of gametes in equal numbers, each with one allele

**Other examples of codominance**

When ‘red’ cattle (homozygous for the red allele) are bred with white cattle (homozygous for the white allele), the offspring are heterozygous and have patches of red and patches of white skin. They are called roan cattle. Two of the alleles that determine our ABO blood group are codominant.

## What is the physical basis for these patterns of inheritance?

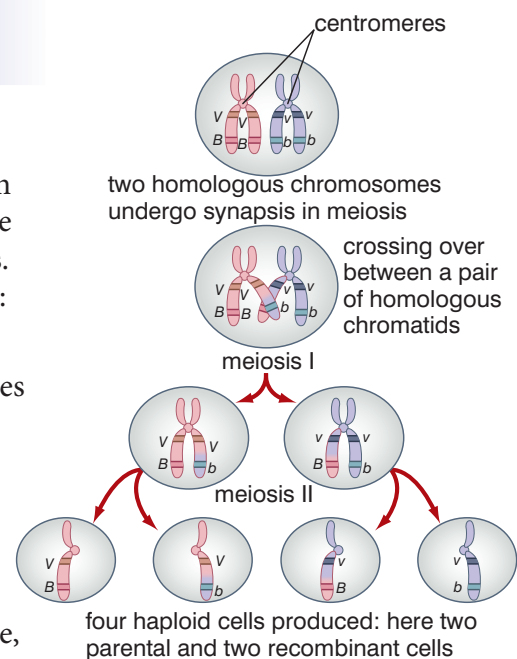
We began this chapter by pointing out that a gene is a part of a chromosome. To understand the patterns of inheritance we have discussed so far, we must look at how chromosomes behave when gametes are formed. For gametes to be formed, special cells in the sex organs of the organism divide by a process known as **meiosis**. When a cell divides in this manner, there are three key outcomes:

- it produces four ‘daughter’ cells
- these daughter cells have only half the number of chromosomes of the original cell; they have one chromosome from each **homologous pair**
- the daughter cells show genetic variation

To understand how this happens we need to look at the stages of meiosis. First, if you think carefully, a cell does not normally divide to produce four cells – it produces two. Therefore, meiosis must entail two divisions. We call these meiosis I and meiosis II. Let us first gain some kind of overview of meiosis, by looking at how just one pair of homologous chromosomes behaves through the two divisions. As you can see from figure 3.17, at the start of the process, each chromosome is a double structure; it is made of two **chromatids** held together by a centromere. This is because the DNA in each chromosome replicated prior to meiosis commencing. Before any division takes place, chromatids from different chromosomes in the homologous pair undergo ‘crossing over’. In this process, they exchange sections of DNA. After this has taken place, meiosis I follows and the two chromosomes that make up the pair are separated into different cells. In meiosis II, the two chromatids that make up each chromosome are separated into separate cells. Notice that, because of crossing over, none of these chromatids are the same. Look at the combinations of alleles on the chromosomes at the start and at the end. There is genetic variation in the daughter cells, which also have only half the original chromosome number – they are said to have the **haploid** number of chromosomes, unlike the parent cell which had the **diploid** number of chromosomes.

During meiosis, the following things happen to the chromosomes:

- They duplicate; the DNA in each chromosome makes an exact copy of itself and histones associate with it to make another chromosome. The original and the copy remain attached by a centromere and are called not chromosomes but chromatids.
- They ‘condense’; when chromosomes are not involved in cell division, they are very long and thin and all the genes can be active. However, they cannot be moved around a cell in this form, so they become much shorter and fatter.
- The chromosomes of a homologous pair (each one by now duplicated) ‘find’ each other (this is called synapsis and no one is quite sure how it happens) and form a **bivalent**.



**Figure 3.17** An overview of meiosis.

### KEY WORDS

**meiosis** the process by which a cell divides to form haploid gametes

**homologous chromosomes** chromosomes that carry genes for the same feature at the same loci (in the same places)

**chromatid** when a eukaryotic cell divides during meiosis, each of its chromosomes divides into two chromatids

**haploid** a haploid cell, usually a gamete, has a single set of chromosomes instead of homologous pairs

**diploid** a diploid cell has homologous pairs of chromosomes

**bivalent** a pair of homologous chromosomes

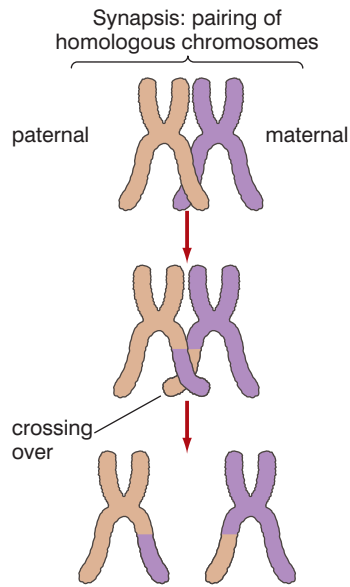


Figure 3.18 Crossing over

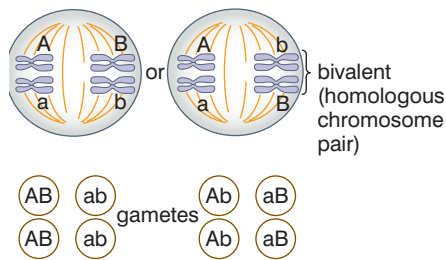


Figure 3.19 Independent assortment in meiosis

- Whilst associated in the bivalent, chromatids from different chromosomes undergo crossing over. These chromatids are called non-sister chromatids; the chromatids that make up one chromosome are sister chromatids. In this process, the chromatids exchange equivalent sections of DNA, and all four chromatids in the homologous pair are genetically different – as shown in figure 3.18.
- The chromosomes (or chromatids) are moved around the cell by fibres that make up a spindle.
- This is achieved by the spindle fibres contracting and pulling the chromosomes/chromatids. In the two divisions of meiosis, the chromosomes attach to the spindles differently so that:
  - in meiosis I, whole chromosomes are moved and the chromosomes that make up a homologous pair are separated
  - in meiosis II, the chromatids that make up each chromosome are separated. This is shown in figure 3.19.

It is pure chance how bivalents arrange themselves at metaphase I. With just two bivalents, there are two possible arrangements and two different sets of gametes. With 23 pairs of chromosomes, there are  $2^{23}$  different combinations. Each bivalent aligns itself independently of the others. This is called independent assortment and is an important source of genetic variation in the gametes produced by meiosis. It explains why alleles of two different genes behave in the way they do in a dihybrid cross.

### The main stages of meiosis

**Meiosis I:** figure 3.20 shows the main stages of meiosis I. It is divided into four phases:

- prophase
- metaphase
- anaphase
- telophase

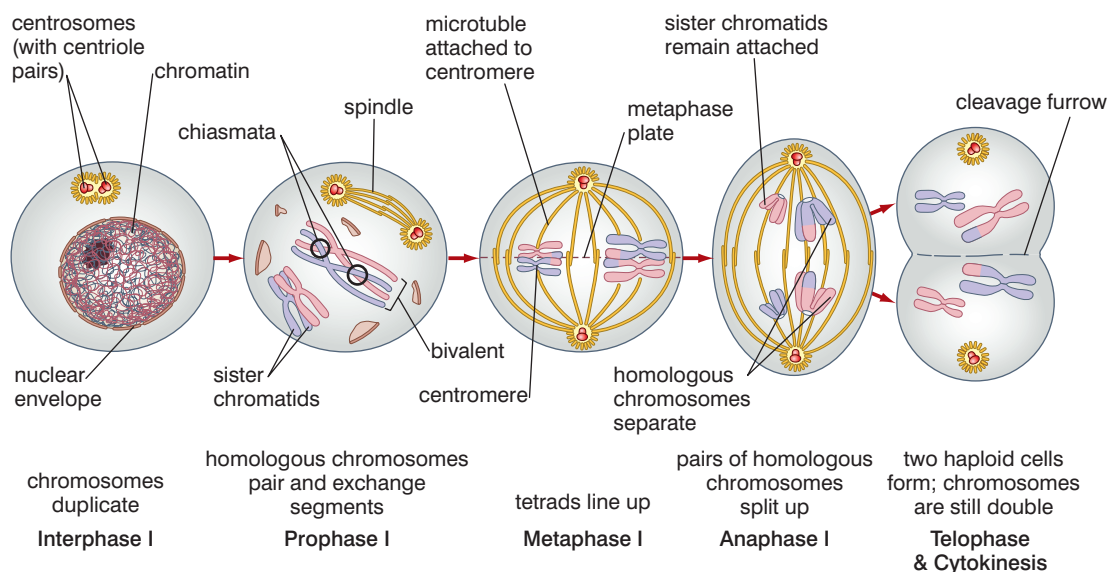


Figure 3.20 Meiosis I



After telophase, the cell may enter ‘interphase’ for a short period, or it may progress straight to meiosis II. The actual division into two cells is called **cytokinesis**.

It is important to note that the cells formed at the end of meiosis I are haploid: each cell contains only one chromosome from each homologous pair. Even though each chromosome comprises two chromatids, it is still only one chromosome and so the cell has half the number of chromosomes of the parent cell.

**Meiosis II:** Figure 3.21 shows the main stages of meiosis II. It is divided into the same four phases, but there are some important differences:

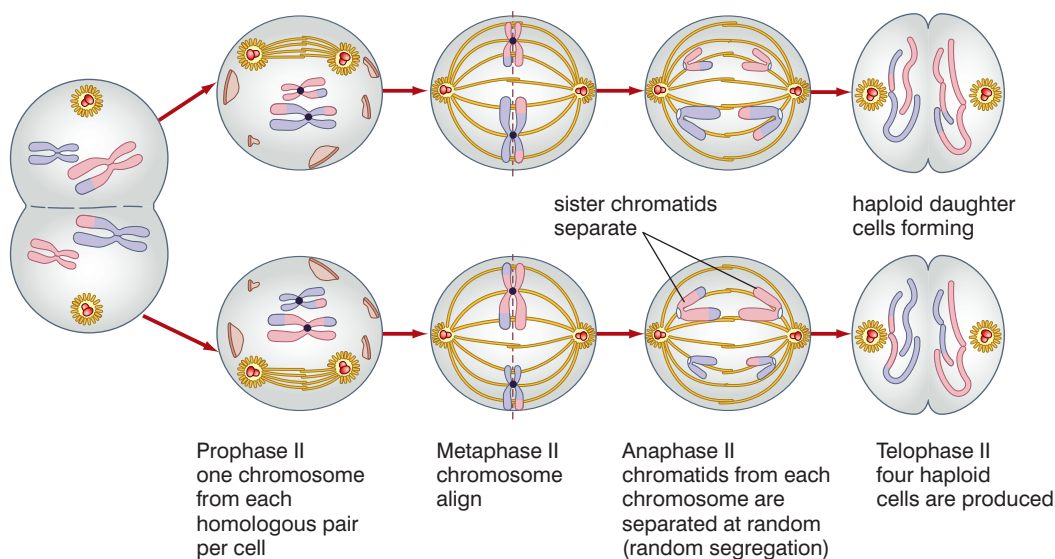
- there is no crossing over in prophase
- the chromosomes line up side by side in metaphase
- chromatids are separated in anaphase

**KEY WORDS**

**sister chromatid** *chromatids from the same chromosome; they have the same alleles in the same sequence*

**non-sister chromatid** *chromatids from different chromosomes of a homologous pair; although the genes are the same and at the same loci, the alleles may be different*

**cytokinesis** *the process that leads up to the cell dividing into two during meiosis*



**Figure 3.21** Meiosis II

**What about alleles that don't segregate at gamete formation – genetic linkage**

Mendel was very fortunate in his choice of organisms with which to experiment. All the alleles of all the genes involved in his experiments did segregate. But this does not always happen; some genes are always inherited together with other genes – they exhibit linkage. This happens when the genes in question are on the same chromosome. A chromosome is a physical unit as are the genes on it, so when a particular chromosome is passed into a **gamete**, all the genes on that chromosome pass into the gamete and none of them pass into another gamete. The genes are linked and inherited together because they are on the same chromosome.

One of the earliest studies of linkage was carried out by two British geneticists, Bateson and Punnett (who also devised the Punnett square). They investigated the inheritance of flower colour (purple or red) and pollen shape (round or long) in sweet peas. The alleles are:

**KEY WORD**

**gamete** *a sex cell*

**Did you notice that we have written the genotypes differently?**

Because P and L (also p and l) are on the same chromosome (linked) we show the genotype as two sets of this unit – PL/PL (rather than PPLL, which we would write for non-linked genes).

- P – purple (dominant)
- p – red (recessive)
- L – long (dominant)
- l – round (recessive)

If we were to cross individuals heterozygous for two features, then we normally would expect the 9:3:3:1 ratio typical of dihybrid inheritance. But these are linked genes, and, because they are linked, the two genes are inherited as a single unit. Starting from pure-breeding (homozygous) parents which were:

- purple-flowered with long pollen (PL/PL)
- red flowered with round pollen (pl/pl),

We can predict what might happen over two generations using the standard genetic diagram.

Parent genotypes **PL/PL** × **pl/pl**

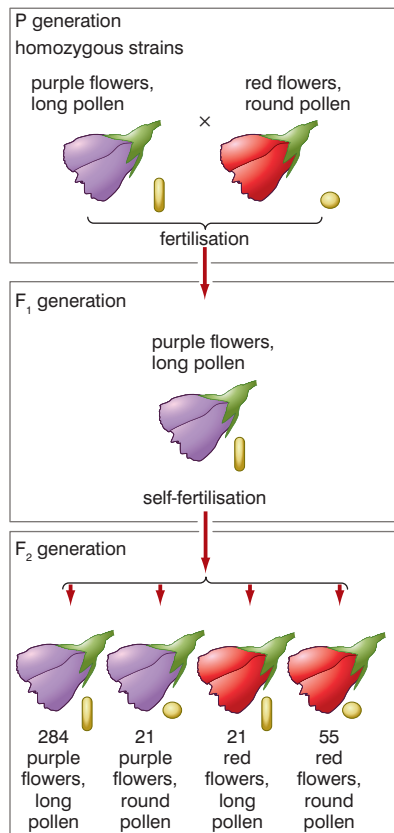
Gametes **PL** **pl**

F<sub>1</sub> genotypes **PL/pl** (self-fertilised)

Gametes male female

**PL pl PL pl**

	<b>PL</b>	<b>pl</b>
<b>PL</b>	<b>PL/PL</b> purple, long	<b>PL/pl</b> purple, long
<b>pl</b>	<b>PL/pl</b> purple, long	<b>pl/pl</b> red, round



**Figure 3.22** Bateson and Punnett's investigation

We now predict not a 9:3:3:1 ratio, but a 3:1 ratio of purple-flowered, long-pollen plants to red-flowered, round-pollen plants. Because the two genes are behaving as a single unit, it is like carrying out a monohybrid cross. Because the genes are inherited in this way, we wouldn't predict any plants that had either purple flowers with round pollen or red flowers with long pollen. But the story doesn't end there. We mustn't forget that when these gametes are formed, they are formed by meiosis and that this involves crossing over at prophase I. The consequence of this is some gametes do contain the combination Pl and others contain pL. So we do, in fact, get the four types of offspring from a cross between two plants both heterozygous for both features – but not in a 9:3:3:1 ratio. The procedure and results from Bateson and Punnett's original investigation are summarised in figure 3.22. What we might have expected from a 9:3:3:1 ratio is:

- 215 purple, long
- 71 purple, round
- 71 red, long
- 24 red, round

and from a 3:1 ratio:

- 286 purple, long
- 95 red, round

The reason we do not get either is because the genes are linked, but there is some crossing over between them during prophase of meiosis I. This produces the types we would not expect from linked inheritance. These types are called recombinant types.

Much of the early research on crossing over and recombination was carried out using fruit flies. They are convenient experimental animals because:

- they are small animals with a short life cycle (just two weeks)
- they are cheap and easy to breed and keep in large numbers
- they have only four pairs of chromosomes per cell
- the chromosomes are large and easily observed
- staining reveals dark bands which correspond to particular genes

**DID YOU KNOW?**

The units of separation on a chromosome are sometimes called centimorgans in honour of Morgan's pioneering work on chromosomes and inheritance.

Using fruit flies in the early 1900s, Thomas Morgan was able to prove, finally, that genes carried on chromosomes are the physical basis of inheritance. One of his students, A H Sturtevant, worked on linkage and crossing over in *Drosophila*. In these experiments, he made predictions about what offspring to expect if there was no crossing over and then counted the number of expected and recombinant types to find the percentage of recombinant types. This percentage of recombinant types is called the crossover value and is a measure of how far apart the genes are on a chromosome. A low crossover frequency indicates that the genes are close together; a high one that they are further apart. This has been used in creating gene maps of chromosomes, where the percentage crossover values are used as 'units of separation' of the genes on the chromosome.

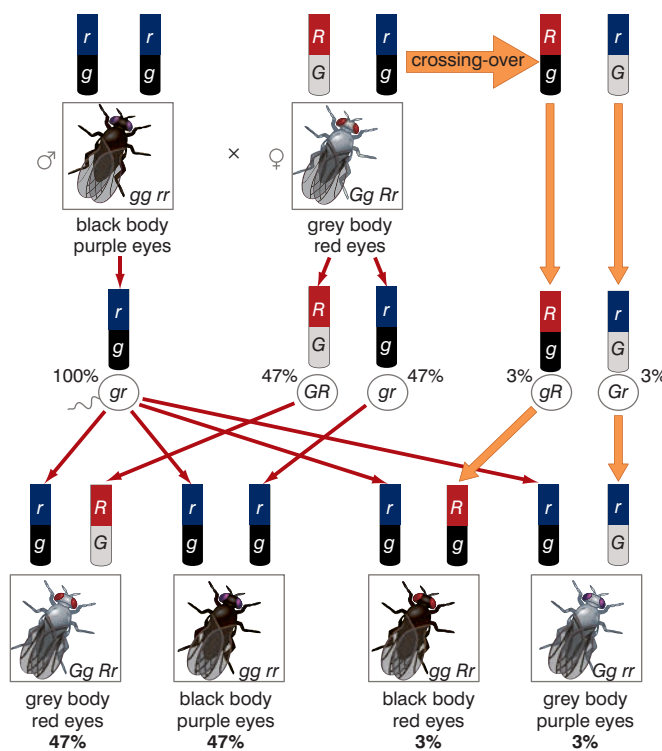


Figure 3.23 Crossing over in *Drosophila*

**KEY WORDS**

**inbreeding** involves breeding animals or plants with close relatives. This can cause problems such as infertility in the resulting offspring

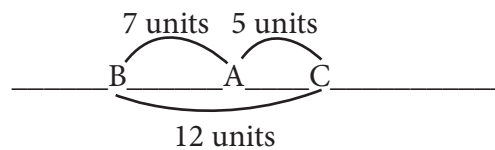
**hybrid vigour** the increased vigour or productivity of organisms resulting from cross-breeding different varieties of the same species

The chance of crossing over occurring between two genes depends on how far apart they are on the chromosome. If they are very close together, then it is unlikely that crossing over will occur between the genes; if they are further apart, it is more likely that crossing over will occur between them and that recombinant types will be formed.

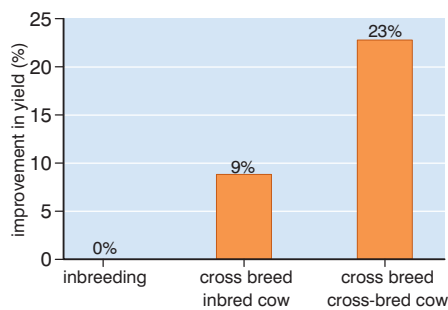
Suppose three genes A, B and C have loci on the same chromosome. From investigations, the crossover values are found to be:

- A and B – 7%
- A and C – 5%
- B and C – 12%

This can only hold true if the genes are arranged as shown below:



Gene mapping has been used to ‘track down’ genes that cause disease (for example, cystic fibrosis and Huntington’s disease) so that the DNA of the gene can be cloned for analysis and research.



**Figure 3.24** The gains in productivity from hybrid vigour

**How is knowledge of genetics important in cross-breeding and inbreeding crops and stock?**

Both cross-breeding and **inbreeding** are aspects of the same process – selective breeding – where organisms are chosen to breed with a specific outcome in mind. In grade 10, you learned about some examples of cross-breeding in Ethiopia. Now we must extend that a little to understand a little more of the genetic principles behind cross-breeding. Cross-breeding is an established breeding method used in sheep and beef cattle breeding to increase overall productivity. It has been used throughout the world and there is a lot of evidence to support the production gains possible from cross-breeding. Commercial cattle farmers may cross-breed animals for two related reasons:

- to take advantage of **hybrid vigour**
- to take advantage of the good qualities of two or more breeds and to combine these qualities to improve market suitability

Hybrid vigour occurs when unrelated breeds or lines (of the same species) are cross-bred. In many cases the offspring from these crosses are more productive (higher milk yields, more beef per carcass) than the average of their parent breeds. The extra performance observed through hybrid vigour is simply the recovery of production losses that occurred through inbreeding in the parental breeds. Hybrid vigour is reduced when animals produced by cross-breeding are mated together.

So what is going on? When a new variety of a species is established, organisms of that type are often bred only with each other. This

is called inbreeding and, whilst it helps to produce a pure line (remember Mendel's pea plants?), it often reduces the productivity of the line. When two lines or varieties are cross-bred, the offspring (the  $F_1$  hybrid) results in an increase in the number of genes that are heterozygous. The 'pure lines' that were used would each be homozygous dominant for the genes which give them their particular characteristics. Crossing the two results in offspring with more dominant alleles, albeit in heterozygous form. However, since the dominant allele in a heterozygote often has the same effect as a dominant allele in a homozygote, this increase in the heterozygosity is what causes the increased vigour of the hybrid. Figure 3.24 shows some of the effects of hybrid vigour in cattle.

In addition to making use of hybrid vigour, cross-breeding can have the advantage of allowing breeds to be chosen for complementary characteristics. For example, cattle produced by cross-breeding dairy and beef breeds can have high milk yields and the ability to produce many calves. However, if mated with large bulls, the offspring of these cattle also grow to large sizes, making them good beef cattle. It would not be possible to achieve both these outcomes with either pure-bred dairy cattle or pure-bred beef cattle. It is important at the outset to choose the cattle carefully – to check that they are likely to produce the desired result.

The same principles can apply in breeding crops. Cross-breeding, natural or planned, has been important in producing many of the high-yielding crop plants we now grow. Figure 3.25A shows a plant breeding station for maize where scientists can test hybrids and their yields. Figure 3.25B shows the healthy and high-yielding 'corn cobs' produced by hybrids.

### DID YOU KNOW?

Because it is the result of increased heterozygosity, the term hybrid vigour is sometimes replaced by **heterosis**.

The cattle only produce milk after they have calved. So if we can produce a breed of cattle that produces potentially high beef calves at the same time as producing a lot of milk (intended for these calves) then the cross-breeding will have been successful.

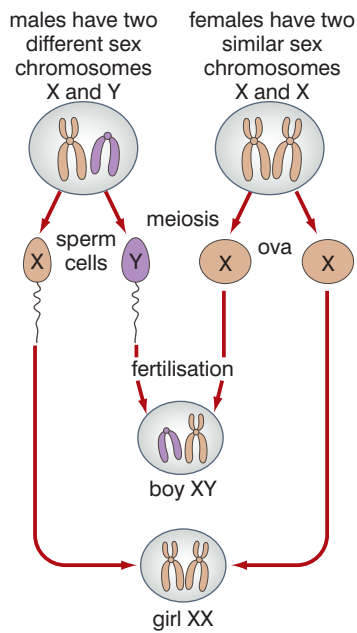


*Figure 3.25 Hybrid vigour in corn (maize)*

What about genes on the sex chromosomes?

### More about sex determination

In grade 10 you learned that sex is determined by the X and Y chromosomes. Males have one X chromosome and one Y chromosome, whereas females have two X chromosomes. Because males have two different sex chromosomes, they are called the heterogametic sex, whereas females are the homogametic sex. In addition, they both have 44 (22 pairs) autosomes – non-sex chromosomes.



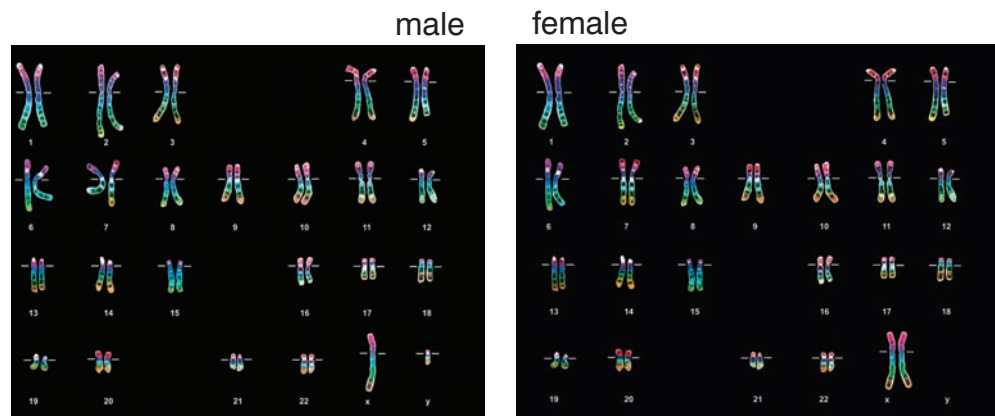
**Figure 3.26** Sex determination in humans

The **karyotypes** in figure 3.27 show the chromosomes from a human male and a human female.

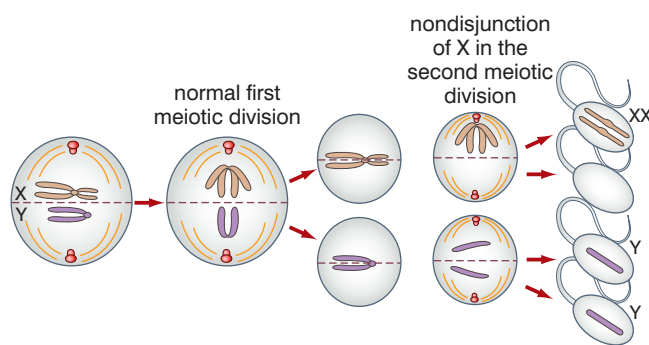
You also learned that in any family, or in any mating in mammals, the predicted ratio of males to females is 1:1, as shown in figure 3.26. However, although it is the Y chromosome that appears to determine a person’s sex, it is, in fact, the action of one gene on this chromosome – the **SRY gene** – that determines the formation of testes.

In the early development of the embryo, a region called the urogenital ridge develops into a ‘bi-potential gonad’. This means that the same structure can develop into either ovary or testis.

When the SRY gene is activated, the bi-potential gonad develops into a testis, and the embryo is male. If the SRY gene is absent (or inactivated for some reason), genes on the X chromosome and on the autosomes cause the bi-potential gonad to develop into an ovary, and the embryo is female.



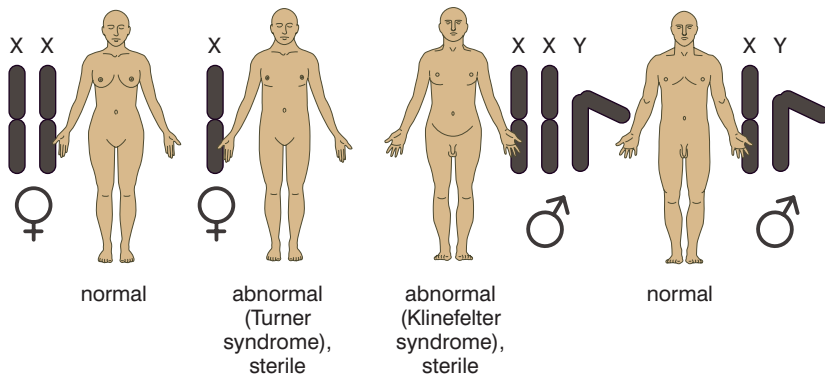
**Figure 3.27** Karyotype of human male and female



**Figure 3.28** Non-disjunction of the sex chromosomes

Because it is the presence or absence of the SRY gene that determines sex, individuals with only one X chromosome and no Y chromosome (written X-) develop into females, but with slightly masculinised features. Similarly, individuals with two X chromosomes and one Y chromosome (XXY) develop into males, but with feminised features. These individuals are also sterile. The abnormal number of chromosomes arises as a result of non-

disjunction of the sex chromosomes during meiosis. This means that the chromosomes do not segregate properly into the gametes, as shown in figure 3.28. When these abnormal gametes fuse with normal gametes, the abnormal chromosome numbers give rise to the conditions described above. This is summarised in figure 3.29.



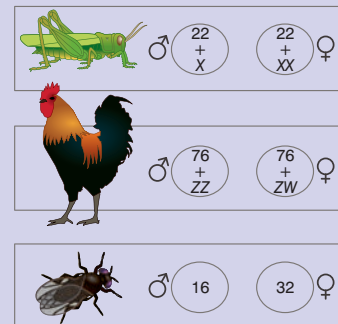
**Figure 3.29** The results of non-disjunction of sex chromosomes

### DID YOU KNOW?

#### Other systems of sex determination

There are several other systems of sex-determination. In birds it is females who are the heterogametic sex and males the homogametic sex! But they don't have X and Y chromosomes – they have W and Z. Females are ZW and males ZZ. There are also other chromosomal systems, as shown in figure 3.30.

In some reptiles, such as alligators, sex is determined by the temperature at which the egg is incubated. Some snails start out male, then become female! In tropical clown fish, the dominant individual in a group becomes female while the other ones are male, and in blue wrasse fish the reverse. Some species have no sex-determination system – they are hermaphrodite (have both male and female sex organs). Hermaphrodites include the common earthworm and some species of snails.



**Figure 3.30** Other systems of sex determination

### Activity 3.6: Making an edible model of DNA!

#### You will need:

- 2 long pieces of boiled potato
- 12 toothpicks
- 9 pink beans (Thymine)
- 9 yellow beans (Cytosine)
- 9 green beans (Adenine)
- 9 orange beans (Guanine)
- 5 paperclips
- masking tape

#### Method:

1. Choose one of the base sequences below.  
Sequence 1: T A C G T A T G A A A C -or-  
Sequence 2: T G G T T T A G A A T T
2. Assemble one side of your DNA molecule. A piece of boiled potato will form the sugar-phosphate backbone of the DNA and beans will be the chemical bases (as shown in the list above). Place a bean on the end of a toothpick so that the point of the toothpick goes all the way through. Anchor the toothpick into the boiled potato backbone.

3. Label the backbone. With a marker or pen and masking tape, label your boiled potato backbone 'DNA-1' or 'DNA-2', depending on which sequence you used.
4. Match the chemical base pairs. Place the coloured bean for the matching chemical base on the other end of each toothpick. Remember that A always pairs with T and C always pairs with G!
5. Complete your DNA model. Attach the other backbone so your model looks like a ladder.
6. Twist your DNA model. Carefully twist your DNA molecule so that it looks like a double helix.
7. Label parts of your DNA out of paper clips and tape. Label one of each of the following: Adenine, Thymine, Cytosine, Guanine, and sugar-phosphate backbone. Make sure your chemical base pairs are correct!
8. If your teacher says it's ok – you can eat it!!

## KEY WORDS

**karyotype** *a photograph of all the chromosomes in a cell arranged in homologous pairs*

**SRY gene** *the dominant gene on the Y chromosome that causes a mammal to develop as a male*

**sex-linked** *a gene found on one of the chromosomes that determine sex*

### The genes on the sex chromosomes

Genes that are found only on the X chromosome or on the Y chromosome are said to be **sex-linked**.

Genes found only on the Y chromosome include those that determine:

- one form of the degenerative condition retinitis pigmentosa (in which eyesight becomes progressively weaker and may lead to blindness)
- one form of deafness

These particular conditions can only be inherited by males, as only males have the Y chromosome.

Genes found only on the X chromosome include those that determine:

- red-green colour blindness
- one form of haemophilia

These conditions can be inherited by females and males as both possess at least one X chromosome.

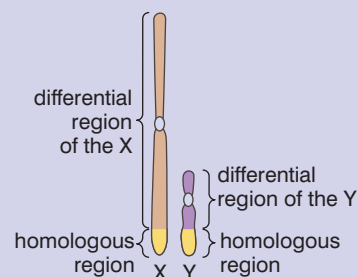
Many of these conditions are determined by recessive alleles, including both red-green colour blindness and haemophilia. If you think about this carefully, you will see why it is that these conditions are more common in men than in women:

- men only have one X chromosome
- if this chromosome carries the recessive allele for haemophilia, there is no corresponding dominant allele on the Y chromosome to mask its effect
- women have two X chromosomes
- both these need to carry the recessive allele for haemophilia for a woman to suffer from the conditions as, if only one of them did, the dominant allele on the other X chromosome would mask its effects

### DID YOU KNOW?

#### About genes on both the X and Y chromosomes

Even though the X and Y chromosomes are very different, they have regions that are homologous (see figure 3.31). The genes in this region follow the same pattern of inheritance as genes on the autosomes. Most of these genes are concerned with control of metabolic activities in cells.



**Figure 3.31** The homologous and differential regions of the X and Y chromosomes



- a man needs to inherit only one X chromosome with a recessive haemophilia allele to suffer from the condition, whereas a woman must inherit two; this is less likely to happen

Sex-linked features determined by recessive alleles on the X chromosome share the following characteristics:

- they are much more common among males (because females must inherit two chromosomes carrying the recessive allele, whereas males must inherit only one)
- affected males inherit the allele from their mother
- affected females inherit one allele from each parent (so the father will be affected)
- females who are heterozygous for the condition are called carriers
- they may 'skip' a generation and then appear in the males only

Genotypes of sex-linked features include the appropriate sex chromosomes as well as the alleles. For example, for red-green colour blindness, B represents the allele for normal vision and b represents the allele for red-green colour blindness. The possible genotypes and phenotypes are:

- $X^BY$  – normal male
- $X^bY$  – affected male
- $X^BX^B$  – normal female
- $X^BX^b$  – carrier female (is not colour blind)
- $X^bX^b$  – affected female

Figure 3.32 shows the inheritance of red-green colour blindness in a family.

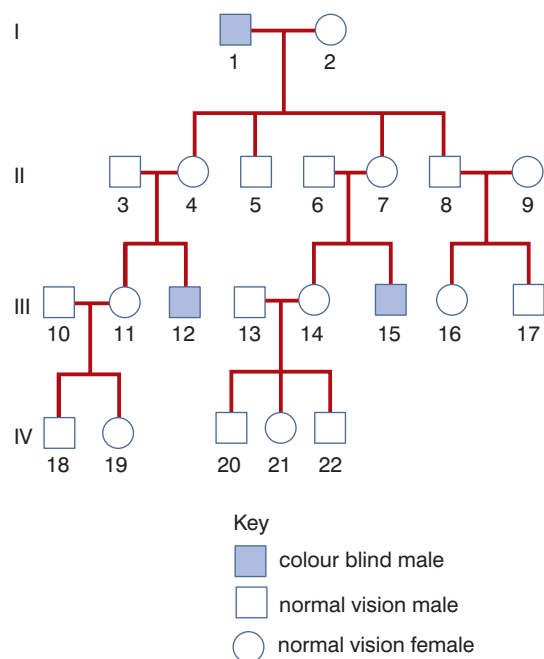
If you were not told that this was a sex-linked feature, there are several hints:

- it clearly skips a generation
- it is more common in the males
- the only affected female has an affected father

To determine the genotypes of individuals in a pedigree of a sex-linked feature, begin with a genotype of which you can be certain. This can only be either an affected male (e.g. genotype  $X^bY$  – with the affected X chromosome inherited from his mother) or an affected female (for example, genotype  $X^bX^b$  – each parent has passed on one affected X chromosome).

You can now work back and work forward from this known starting point. For example, what are the genotypes of individuals 11 and 7?

Individual 7 is the mother of individual 15 – an affected male ( $X^bY$ ). The  $X^b$  chromosome must have come from the mother (individual 7) who is unaffected and so must be  $X^BX^b$ .



**Figure 3.32** The inheritance of red-green colour blindness in a family

**KEY WORDS**

**sex-influenced trait** *a sex-influenced trait is more likely to occur in one sex but may sometimes occur in the other sex*

**sex-limited trait** *a sex-limited trait occurs only in one sex and never occurs in the other sex*

**What are sex-influenced and sex-limited traits?**

Both these are examples of traits that are expressed differently in the two sexes. However, the genes that determine these traits are not carried on the sex chromosomes, so they cannot be said to be sex-linked.

Pattern baldness (often called male pattern baldness) is an example of a **sex-influenced trait**. It is the high concentrations of the male sex hormone testosterone that makes the allele dominant in males. Because of this, males need only inherit one pattern baldness allele and they will go bald (because the allele is dominant in males). It doesn't matter whether the second allele is a baldness allele or a non-baldness allele. Females must inherit two before they go bald (because the allele is recessive in females). Even then the level of baldness in females is minimised by the low level of action of the alleles.

**Sex-limited traits** are only expressed in one sex. Both males and females have genes that stimulate lactation, but these are only expressed in females. The condition of cryptorchidism (undescended testicles) is genetically determined, but clearly can only ever be expressed in males.

**Review questions**

Choose the correct answer from A to D.

- Two parents of genotype Aa are cross-bred. The alleles do not show codominance. What proportion of the offspring will look like their parents?
  - none
  - $\frac{3}{4}$
  - $\frac{1}{4}$
  - $\frac{1}{2}$
- A woman with blood group A and a man with blood group B could potentially have offspring with which of the following blood groups?
  - A
  - B
  - O
  - all blood groups
- In an organism of genotype Aa, half the gametes carry the A allele and half carry the a allele. This is due to:
  - dominance
  - recessiveness
  - independent assortment
  - segregation

4. The genotype of a homozygote could be:
- A AA
  - B aa
  - C Aa
  - D XX
5. A plant has a genotype AaBb. There is no linkage of the genes. The gametes it will produce are:
- A AB and ab
  - B Aa and Bb
  - C AA, aa, BB and Bb
  - D AB, Ab, aB and ab
6. A tall pea plant with purple flowers (both determined by dominant alleles) is crossed with a short plant with white flowers. There is no linkage of the genes. If the tall, purple-flowered plant is heterozygous for both traits, the offspring will be:
- A 1 purple tall:1 white short
  - B 3 purple tall:1 white short
  - C 9 purple tall:3 purple short:3 white tall:1 white short
  - D 1 purple tall:1 purple short:1 white tall:1 white short
7. Cross-breeding results in:
- A an increase in heterozygosity
  - B hybrid vigour
  - C an increase in the number of dominant alleles
  - D all of the above
8. Which of the following statements concerning multiple allele inheritance is not true?
- A A gene has more than two alleles.
  - B An individual will have more than two alleles of the gene.
  - C There are more than two alleles in the population.
  - D The alleles may be dominant, recessive or codominant.
9. Which of the following is not true of sex limited traits?
- A They are determined by genes on the autosomes.
  - B They are expressed in only one sex (male or female).
  - C They are carried on the X chromosome.
  - D They often result in sexual dimorphism (very different physical appearance in male and female animals).
10. It is characteristic of sex-linked traits that they:
- A occur more frequently in males than in females
  - B rarely skip a generation
  - C are always determined by genes found on the Y chromosome
  - D none of the above

**KEY WORDS**

**DNA** (deoxyribonucleic acid) is the molecule that stores genetic information

**histone** the core of a chromosome around which the chromosome's DNA is wrapped.

**chromatin** the loose form taken by a chromosome when the cell is not dividing

**RNA** (ribonucleic acid) another molecule that stores genetic information. Genetic information stored as DNA is transcribed into RNA as part of the process for making proteins.

**double helix** describes the structure of a DNA molecule. It consists of two anti-parallel polynucleotide strands

**nucleotide** a component of a nucleic acid molecule. It consists of a phosphate group, a sugar called a deoxyribose (or ribose) and a nitrogenous base

**Do you remember from grade 11 about globular proteins?**

Globular proteins are proteins that have a tertiary structure that is loosely spherical.

**3.2 Molecular genetics**

By the end of this section you should be able to:

- Describe the structure of a chromosome.
- Describe in detail the structure of the DNA molecule.
- Name the four nucleotides that build up the DNA molecule.
- Construct a model of DNA showing the base pair between complementary nucleotides.
- Describe the semi-conservative replication of DNA.
- Describe the significance of some of the uses of gene technology in forensic science (such as genetic fingerprinting).
- Describe how genetic fingerprints are produced.
- Define and give examples of cloning.
- Understand that genes can be cloned and explain in outline how this is achieved.
- Describe, in outline, the procedures involved in genetic engineering and appreciate that whilst there are many advantages that result from the process, there are also some ethical concerns about some of the procedures.

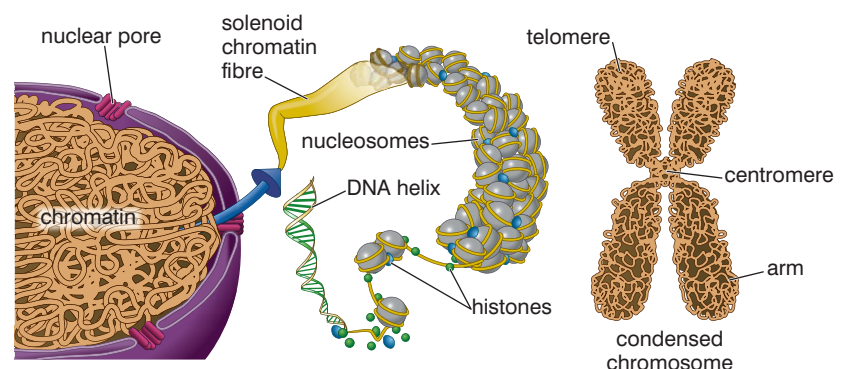
**What is a chromosome really like?**

It all depends when you look! Chromosomes are made from two chemicals:

- **DNA** (deoxyribonucleic acid) and
- **histones** (a set of globular proteins)

Figure 3.33 shows the way in which the DNA molecule wraps itself around the histone molecules to form a fibre of **chromatin**.

When a cell is not dividing, the chromatin is loosely organised throughout the nucleus as loops of chromatin fibres. Individual chromosomes cannot be distinguished. The 'loose' organisation allows the genes to be active. As a cell prepares to divide, the



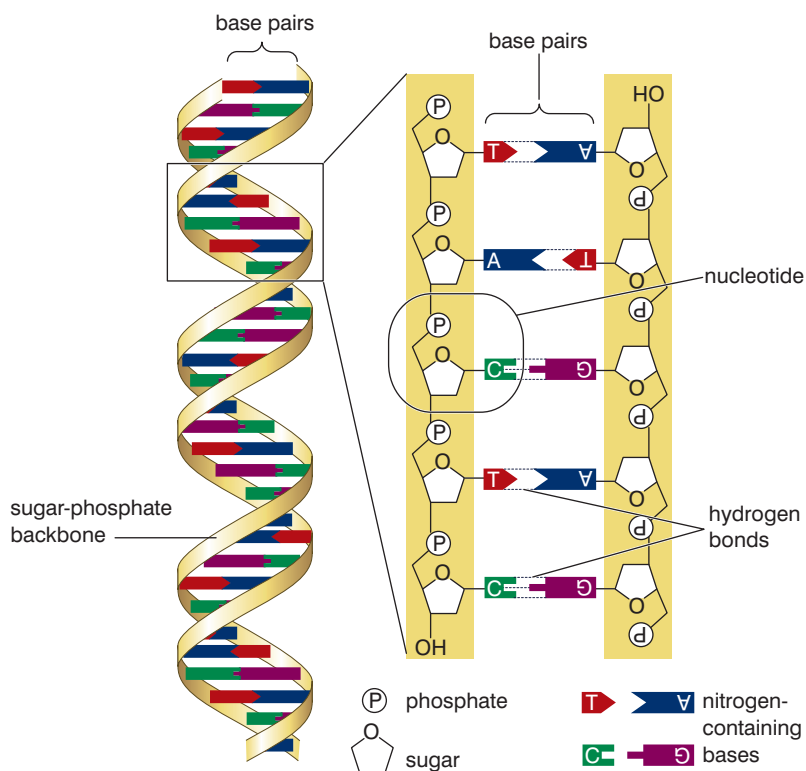
**Figure 3.33** DNA and histones are combined to form chromatin, which is organised into chromosomes.

chromatin loops (which by now will have duplicated themselves) become compacted or 'condensed' to form a chromosome that is visible (when stained) under a light microscope. The compact state of the chromatin in such a chromosome means that the genes are too tightly packed to be active.

Genes are short sections of DNA within the chromosome. We shall learn more about the structure and action of genes in section 3.3.

### How is a molecule of DNA put together?

DNA – Deoxyribo-Nucleic Acid is one of two types of nucleic acids. The other is **RNA** – Ribo-Nucleic Acid. You already know something of the structure of DNA from your grade 10 work on genetics, and your studies of biological molecules in grade 11, but let's recap these basics. Figure 3.34 shows part of a DNA molecule.



#### Do you remember from unit 1 about DNA in different cells?

This organisation of DNA with histones into chromosomes is found in all eukaryotic cells. But the molecules of DNA in prokaryotic cells are different in a number of ways:

- they are much smaller
- they are circular, not linear as in eukaryotic cells
- they are not associated with histones to form chromosomes

*Figure 3.34 The structure of DNA.*

You can see that it is made of two strands joined together and wound into a **double helix**. If you look carefully, you will see that the structures in one strand are 'upside down' when compared to the same structures in the other. This is because the strands are 'anti-parallel'. The 'start' of one strand is paired with the 'end' of the other strand.

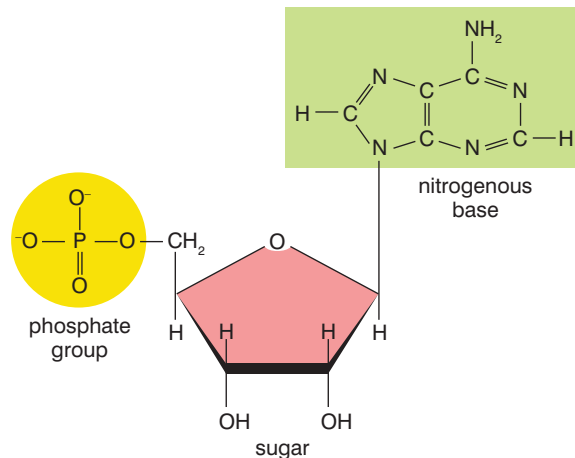
The basic unit of a DNA strand is a **nucleotide**. There are four types of nucleotides. These are:

- Adenine-containing nucleotide
- Guanine-containing nucleotide
- Cytosine-containing nucleotide, and
- Thymine-containing nucleotide (in DNA, or Uracil-containing nucleotide in RNA).

As you learned in grade 11, all nucleotides have the same three components:

- a phosphate group
- a pentose sugar (deoxyribose in DNA nucleotides and ribose in RNA nucleotides)
- one of four nitrogenous bases – Adenine, Cytosine, Guanine and either Thymine (DNA) or Uracil (RNA)

The structure of a nucleotide is shown in figure 3.35.



**Figure 3.35** The structure of a nucleotide

DNA is a huge molecule made from two anti-parallel polynucleotide strands. The nucleotides are held together by bonds between the sugar in one nucleotide and the phosphate group in the next. The base does not take in this linking of the nucleotides in a strand. For this reason, we sometimes say that there is a 'sugar-phosphate backbone' holding each DNA strand together. The nucleotides in one strand are paired with nucleotides in the other according to the base-pairing rule.

This states:

- Adenine-containing nucleotides will always be opposite Thymine-containing nucleotides
- Cytosine-containing nucleotides will always be opposite Guanine-containing nucleotides

Because of this base-pairing rule, all the bases on one strand of a DNA molecule are base-paired to those on the other strand. We say that the sequences of bases on the two strands are complementary.

DNA is a very stable molecule at normal temperatures. The individual hydrogen bonds that hold the two strands together are quite weak, but the sheer number of them in the whole molecule ensures that the two strands stay in position. The bonds that hold the nucleotides together in each strand are much stronger than the hydrogen bonds. The stability of the DNA molecule is important in ensuring that the genetic code – held in the DNA molecule – does not become corrupted in any way.

#### A word of warning ...

Do not confuse DNA *strands* with DNA *molecules*. Each molecule of DNA is made from two strands.

### Activity 3.7: Extracting DNA from bananas

#### You will need:

- A banana, cut into chunks
- 5 g washing up liquid or hand soap
- 2 g salt
- 100 cm<sup>3</sup> tap water
- 100 cm<sup>3</sup> of ice-cold ethanol
- a knife
- a pipette
- a test tube
- a thermometer
- access to a blender
- filter paper, a filter funnel and a beaker
- another 250 cm<sup>3</sup> beaker to act as a water bath

#### Method:

1. Mix together the washing up liquid, the salt and the tap water and stir **slowly** (try to produce as little foam as possible) until the salt has dissolved. This mixture is called an **extraction buffer**.
2. Blend the chunks in the blender (this is to break open the cells).
3. Add the extraction buffer to the banana and MASH!
4. Set up your water bath so that the temperature of the water is 60°C.
5. Stand the banana and buffer in the water bath for 15 minutes. Try to maintain the temperature at 60°C by adding hot or cold water as necessary.
6. Remove the beaker from the water bath and filter the banana mixture through a fine sieve or coffee filter paper into the other beaker. You should be left with a greenish liquid, which contains the banana DNA.
7. Half-fill a test tube with some of this filtrate.
8. Pour the ice-cold alcohol **slowly** down the side of the test tube. The alcohol will form a transparent layer on top of the banana mixture, as the alcohol is less dense.
9. Where the two liquids meet, the DNA, which was dissolved in the buffer mixture, will precipitate (come out of solution).
10. Remove the DNA from the ethanol/buffer with the pipette and place it in a Petri dish lid or on a tile.
11. Test the DNA with litmus paper to show that it really is deoxyribonucleic acid.

#### DID YOU KNOW?

Because adenine always pairs with thymine and cytosine with guanine, the amount of adenine in any DNA molecule will always be the same as the amount of thymine. And the amount of cytosine will always equal the amount of guanine. So, if you know the percentage of just one base in a DNA molecule, you can work out the percentage of all the others. Here's how.

Suppose a DNA molecule contains 16% cytosine. It must also contain 16% guanine. That's 32% so far, leaving 68% of the DNA made from adenine and thymine. But as the amounts of these two are equal, there must be 34% of each.

**KEY WORDS**

**DNA helicase** *the enzyme that initiates the separation of the polynucleotide strands during DNA replication*

**DNA polymerase** *the enzyme that initiates the building of a new complementary polynucleotide strand of DNA following separation of the original two strands*

**Activity 3.8**

Making a model of DNA can make it easier to understand. Working in small groups, plan and make a model of the DNA molecule. You could use modelling clay, card, paper or anything else you think would work well. You can make a model of the double helix, or make a model which can be used to show how DNA replicates. You might even just choose to make a big poster showing the molecule. Evaluate the models made by your peers and decide which is the most useful for explaining the structure of this important molecule.

**How does the DNA molecule replicate itself?**

The ability of a DNA molecule to make an exact copy of itself is the basis of all methods of reproduction and the basis of passing on genetic information from one generation to the next. When cells divide, it is important that the daughter cells formed (unless sex cells are being formed) contain the same genetic information as the parent cell that produced them. To achieve this, DNA must be able to replicate itself exactly.

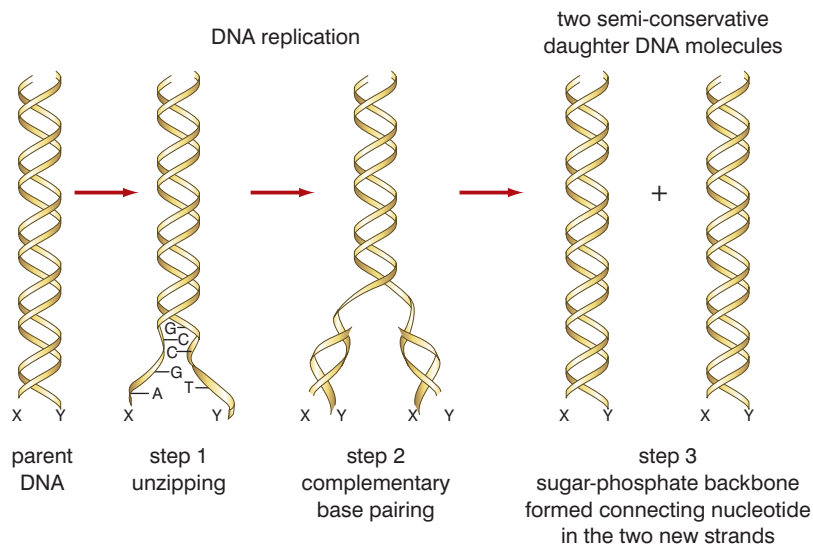
DNA molecules exist within chromosomes in the nucleus and are surrounded by a 'soup' of free DNA nucleotides – the 'building blocks' with which to build new DNA molecules. Even though they did not know the details, in 1953, Watson and Crick (the discoverers of the structure of DNA) proposed that DNA must replicate semi-conservatively. This means that the DNA molecule replicates in such a way that:

- each new DNA molecule formed contains one strand from the original DNA
- both new DNA molecules formed are identical to each other and to the original molecule

The process involves several enzymes and proteins, but the key stages are as follows:

- Molecules of the enzyme **DNA helicase** break hydrogen bonds and 'unwind' part of the helix of the DNA molecule, revealing two single-stranded regions.
- Molecules of **DNA polymerase** follow the helicase along each single-stranded region, which acts as a template for the synthesis of a new strand.
- The DNA polymerase assembles free DNA nucleotides into a new strand alongside each of the template strands. The base sequence in each of these new strands is complementary to its template strand because of the base-pairing rule, A-T, C-G.
- The processes of unwinding followed by complementary strand synthesis progresses along the whole length of the DNA molecule.
- The result is two DNA molecules that are identical to each other (and to the original molecule); each contains one strand from the original DNA molecule and one newly synthesised strand that is complementary to this.





**Figure 3.36** Semi-conservative replication of DNA

### DID YOU KNOW?

Gene cloning means making multiple copies of a gene. There are several ways in which this can be done. The principal methods are divided into two main categories; these are:

- **in vivo cloning** – the gene is introduced into a cell and is copied as the cell divides
- **in vitro cloning** – this does not take place in living cells but the DNA is copied many times over using the **polymerase chain reaction (PCR)**. This process mimics the natural semi-conservative replication of DNA in a machine called a PCR machine.

There are advantages and disadvantages to both methods of gene cloning. In vitro cloning using the PCR is both quicker and cheaper. Billions of copies of a gene can be made within a few hours at low cost. However, if the gene is to be used by an organism to make a product – for example, by a bacterium to allow it to make insulin – then in vivo cloning delivers the gene already in the organism.



Figure 3.37 A stem cutting

**KEY WORDS**

**clone** a clone of an organism is a group of organisms that are genetically identical to each other and to the organism from which they were derived

**genetically modified organism** an organism created using genetic engineering which contains a transferred gene or genes

**How are organisms cloned?**

The term **clone** is often applied to whole organisms as well as to genes. A clone of organisms is a group of organisms produced asexually from one parent. The members of the clone are genetically identical to each other and to the parent organism. Plant cuttings are clones and the thousands of plants produced from one parent by micropropagation also represent a clone.

To take a simple ‘stem cutting’, just cut off a region of a stem near to a bud – as shown in figure 3.37. Remove some of the leaves so that it will not lose too much water. Dip the cut end in some hormone rooting powder and plant the cutting in some compost. Keep the cutting well watered and within a few weeks it will have developed its own root system and be an independent plant. It will be genetically identical to the parent plant the cutting was taken from. If several are taken from one plant, they will form a clone.

Cloning plants by taking cuttings has been practised for thousands of years. More recently the technique of micropropagation made it possible to produce a clone of thousands of identical plants from just one parent plant. Typically, a small section of the growing point of a shoot is taken and sub-divided. These small groups of a few hundred cells are placed in test tubes containing a special medium with hormones that induce root growth. They are then transferred to another medium containing hormones to induce shoot growth. When they have grown sufficiently, the small plantlets are transferred to a compost and grown on. In this way, thousands of identical plants can be produced. Most of the world’s bananas are now produced by micropropagation. The reason why it is relatively easy to clone plants is that many more plant cells retain the ability to divide than is the case in animals. You cannot just cut off a piece of animal and place it in a special medium and watch it grow! However, animals have been cloned. The first mammal to be cloned, and still the most famous, was Dolly the sheep.

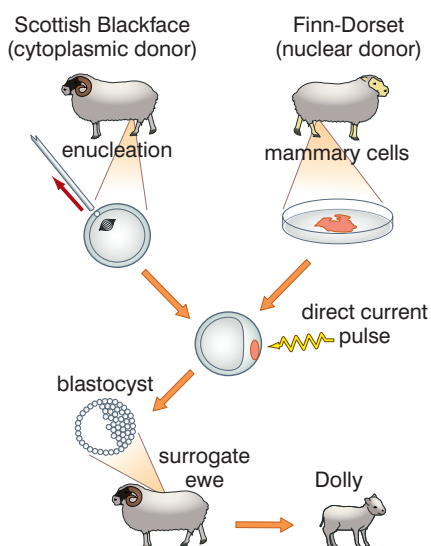


Figure 3.38 How Dolly the sheep was produced

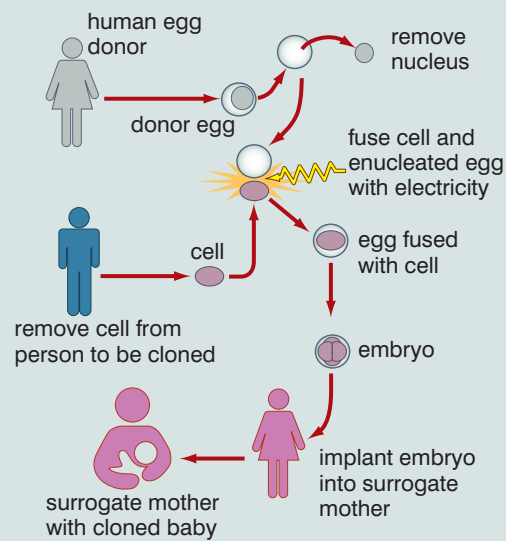
Dolly’s genetic mother was a type of sheep called ‘Finn-Dorset’. Dolly was produced by transferring a diploid nucleus to an egg cell that had been enucleated (had its nucleus removed). Once the nucleus had been successfully transferred, the egg cell was stimulated to divide by a small electric current. When development had reached a stage called a blastocyst, the embryo was implanted into a surrogate ‘mother’ ewe. Seven months later, Dolly was born. She was genetically identical to the Finn-Dorset ewe (female sheep) from whom the genetic material had been obtained. Figure 3.38 summarises these procedures.

**What is genetic engineering?**

Genetic engineering is a process in which the genome of an organism is altered, usually by having an extra gene from a different organism added. The organism is then a **genetically modified** or a **transgenic** organism. Much of the early work on genetic engineering was done to genetically modify bacteria. This was often

**What do you think about cloned humans?**

Some biologists believe that, although there are important differences between sheep and humans, the technology and knowledge is now available to clone human beings. Is this acceptable? There are many issues involved here and different people hold very strong views for and against human cloning. At the moment it is illegal throughout the world. Should it stay that way forever, or is that just placing an obstacle in the way of scientific progress?

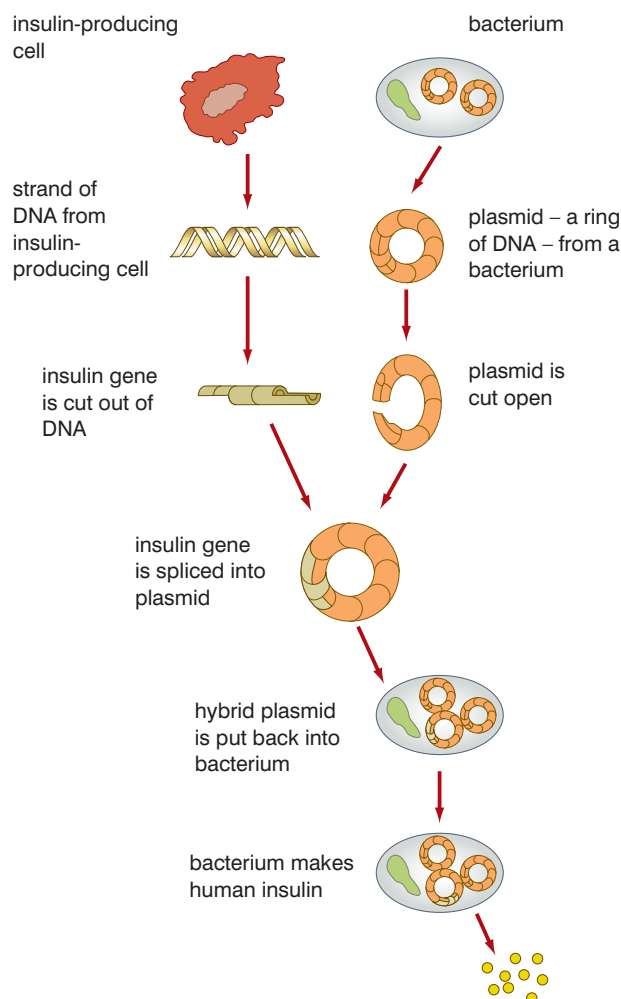


*Figure 3.39 Should this ever be legal?*

done with the aim of altering the bacteria so that they would make a useful product. One of the first of these products to be produced by transgenic bacteria was human insulin. The gene that controls the production of human insulin was extracted from human pancreas cells and transferred to the bacteria. Once modified, the bacteria were then cultured on a massive scale in a fermenter and the insulin harvested and purified before distribution.

**KEY WORD**

**transgenic organism** a genetically modified organism that contains a gene or genes transferred from another organism belonging to a different species



**Activity 3.9**

Should human cloning ever be allowed? Set up a debate about this. Have a class vote to measure opinions before the discussions. Plan a speech either explaining why human cloning should be made possible and allowed, or explaining why it should never be allowed. Carry out your debate in small groups and then vote again to see if the views of your class have changed.

*Figure 3.40 The main steps in genetic engineering*

**Activity 3.10**

Chose one recent example of genetic engineering eg golden rice which produces the precursor of vitamin A, bananas and tomatoes which can be engineered to produce a vaccine for hepatitis B, plants which are engineered to produce pesticides in their leaves or are herbicide resistant, using genetic engineering to cure genetic diseases such as SCID or cystic fibrosis.

Find out as much as you can about the case you have chosen, considering both the potential benefits and the problems and produce a presentation about it which you can deliver to the rest of your class.



**Figure 3.41** Genetically modified zebra fish – glofish

Genetically modified bacteria produce a range of products, including:

- enzymes for the food industry
- thermostable enzymes for washing powders
- human insulin
- human growth hormone
- vaccines (for example, for prevention of hepatitis B)
- bovine somatotrophin (to increase milk yield and muscle development in cattle)

Plants have also been genetically modified so that they:

- are disease resistant
- have an improved yield
- produce a specific product (for example, golden rice is genetically modified rice that produces beta-carotene – important in the formation of vitamin A, which prevents night blindness)

Fewer animals have been genetically modified, but genetically modified salmon and *Tilapia* fish grow bigger and faster than the non-modified fish and could prove to be an important source of protein in some regions of Africa. Other animals have also been genetically modified to produce specific products; this is sometimes called ‘pharming’.

Most of the genetic modifications that have been carried out have been with the aim of improving yield of a crop plant or a stock animal, or changing organisms so that they will produce a useful product – like insulin. But some do not fall into this category. The glofish in figure 3.41 literally glow in the dark because they have had a gene added from a bioluminescent jellyfish. It was originally produced as a warning against water pollution – it would only glow in polluted water. Now they are produced to glow in various colours for the pet market.

Genetic engineering has many potential benefits. Some of these are described below:

- Disease could be prevented by detecting people/plants/animals that are genetically prone to certain hereditary diseases, and preparing for the inevitable.
- It may be possible to treat infectious diseases by implanting genes that code for antiviral proteins specific to each antigen.
- Genetically engineered plants and animals can be produced to give increased growth rates and reduced susceptibility to disease. This would reduce the use of fertilisers and pesticides and the chemical pollution that results from their use.
- Animals and plants can be ‘tailor made’ to show desirable characteristics. Genes could also be manipulated in trees, for example, to absorb more CO<sub>2</sub> and reduce the threat of global warming.

- Genetic engineering could increase genetic diversity, and produce more variant alleles which could also be crossed over and implanted into other species. It is possible to alter the genetics of wheat plants to grow insulin, for example.
- Genetic engineering is a much quicker process than traditional selective breeding. This often took many generations to bring about the desired improvement. A single gene transfer may achieve the same result.

### How can gene technology be used in forensic science?

Fingerprints have been used for many years to help place a suspect at the scene of a crime. They continue to provide strong evidence because, with the exception of identical twins, an individual's fingerprints are unique. They do not change throughout life.

**Genetic fingerprinting** has nothing to do with actual fingerprints. It is a technique for comparing the DNA of different people. Much of the DNA in the cells of the body is what is known as non-coding DNA. The non-coding DNA is found between genes and contains base sequences that are repeated, sometimes many times over. These repeating sequences of non-coding DNA are called mini-satellites and it is these that form the basis of a genetic fingerprint. The mini-satellites are inherited along with the coding DNA from one or other parent.

The DNA used for analysis can be obtained from a sample of blood (white blood cells could supply the DNA), skin or semen – in fact, from any type of cell that has a nucleus. If the sample does not contain sufficient DNA for analysis, then the amount can be amplified using the polymerase chain reaction.

The main stages in preparing a genetic fingerprint are as follows:

- DNA is isolated from the cells.
- The DNA is cut into fragments using one or more restriction enzymes. The fragments that are obtained are treated with alkali to separate the strands of each DNA fragment.
- The fragments are separated by gel electrophoresis. Smaller fragments (with a lower molecular mass) move further than larger fragments.
- The (invisible) pattern of separated DNA fragments is transferred from the gel to a nylon membrane. The membrane is placed over the gel in a tray of 'flow-buffer' and is held in place by paper towels and a weight. The buffer soaks up through the gel, carrying the fragments of DNA with it. The buffer can pass through the membrane (to be absorbed by the paper towels), but the DNA cannot. It remains in the nylon membrane in the same relative position as it was in the gel.
- A radioactive gene probe is applied to the membrane. This is made of single-stranded DNA (called c-DNA) and binds with base sequences in the mini-satellite regions.

### KEY WORD

**genetic fingerprinting** a forensic technique that is used to try to solve crimes by matching DNA found at crime scenes with the DNA of suspects

### DID YOU KNOW?

The technique of transferring DNA fragments from the gel to the nylon membrane was devised by Professor E M Southern and is called Southern blotting.

### Electrophoresis

Gel electrophoresis is a technique that uses a thick block of gel (jelly-like material) to act as a 'molecular sieve'. Fragments of DNA (or protein molecules) are separated by applying an electrical field across the gel. Because DNA fragments are negatively charged, they move to the positive electrode. The smaller fragments move more quickly than the larger ones and so move further in the same time.

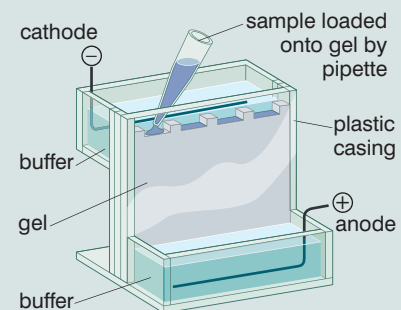
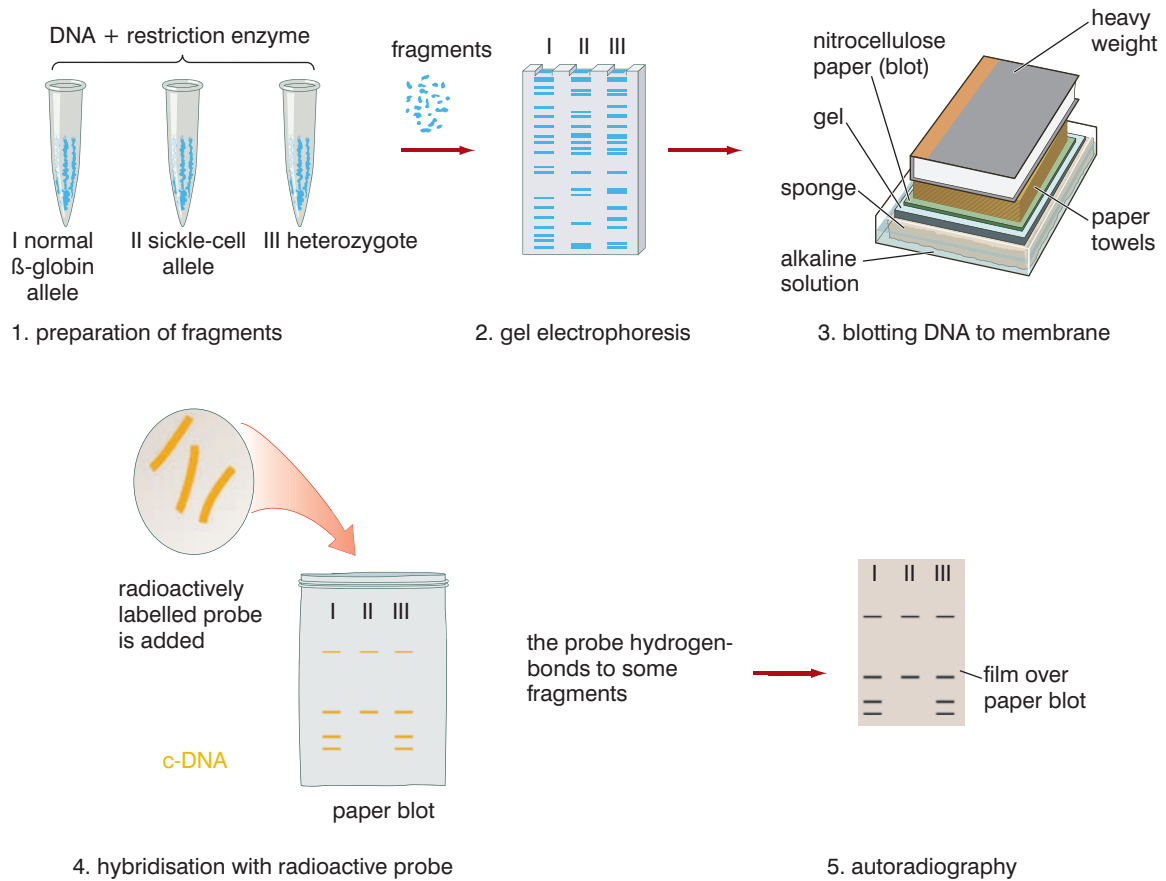


Figure 3.42

- The membrane is placed over a piece of X-ray film to reveal the positions of those fragments that have bound to the probe.



**Figure 3.43** Preparing a genetic fingerprint

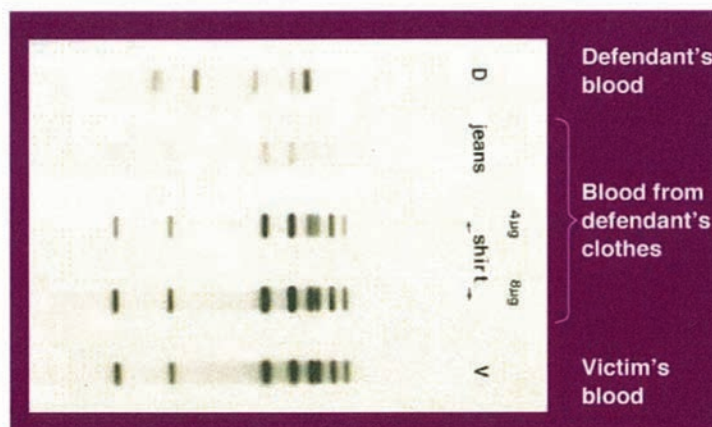
**DID YOU KNOW?**

The size of DNA molecules is usually measured in kilobase pairs (thousands of pairs of bases). The fragments used in a genetic fingerprint are single stranded, so there are no base pairs. Their size is measured in kilobases.

The chance of two people having the same genetic fingerprint (unless they are identical twins) is about 1 in 1 000 000. This means that a genetic fingerprint can be used to provide strong evidence of involvement in or innocence of a crime.

Look at the fingerprints in figure 3.44 of a person accused of attacking a person, together with the victim's genetic fingerprint.

Clearly the blood on the defendant's clothes has the same DNA as the victim's blood – it must be the victim's blood. So this is strong evidence that the defendant was at least present at the time.



**Figure 3.44** DNA fingerprints from the defendant and victim

## What are the moral and ethical considerations of using gene technology?

Is genetic engineering right or wrong? A debate about right and wrong involves the principles of ethics and morality.

- Morality is our personal sense of what is right, or acceptable, and what is wrong. Morality is not necessarily linked to legality.
- Ethics also involve a sense of right and wrong. However, ethics are not individual opinions. They represent the 'code' adopted by a particular group to govern its way of life.

Many people have passionate views about genetic engineering. Some hold an unshakeable belief in the technology, which they see as something that will bring great benefits to humankind. Other people hold the equally strong belief that genetic engineering is tampering with nature and is likely to cause serious ecological and physiological problems. Some of the issues people are concerned about are discussed below.

- A species is sacrosanct and should not be altered genetically in any way. This is a personal, moral viewpoint. People who take this moral stance usually do so on the basis that the genes from one species would not normally find their way into another species. However, genes have been 'jumping' from one species to another (albeit at a very low frequency) for millions of years.
- Not enough is known about the long-term ecological effects of introducing genetically modified organisms into the field. They may outcompete wild plants and take over an area. This is also a moral viewpoint. The effects of any new crop cannot be determined without field trials. Ten thousand years ago, the early farmers who cross-bred wild wheat plants to produce the forerunner of today's strains could not have known what impact these would have. Does this make it wrong?
- If plants are genetically engineered to be resistant to herbicides, the gene could 'jump' into populations of weeds and other wild plants. This is perfectly true – it could. However, non-genetically modified herbicide-resistant strains of plants already exist. The gene could just as easily jump from these.
- Gene technology might give doctors the ability to create designer babies. It could become possible to obtain a newly fertilised human egg, determine its genotype and ask the parents which genes they would like to be modified. Initially, only genes that cause disease might be replaced. Subsequently, the technology might be used to replace other genes. Most doctors would find this morally and ethically unacceptable. They might consider replacing genes that cause disease but not replacing genes merely to improve a child's image in the eyes of its parents. However, if such practices become possible, who will define for doctors what is ethically acceptable? What will be the dividing line between cosmetic gene therapy and medical gene therapy?

### DID YOU KNOW?

Although the human genome project has identified all the base sequences in the human genome, much of this is 'junk' (non-coding) DNA and the exact start and end points of many genes are not yet known.

### Activity 3.11

Penicillin was first discovered in a mould growing in a laboratory by Alexander Fleming. This antibiotic has gone on to save millions of lives. It is a great example of biotechnology in action. Find out as much as you can about the history of penicillin and its manufacture. Make a timeline to help you tell the story.

- Using genetic fingerprinting to combat crime will only be useful if there is a genetic database – a file of the genetic fingerprints of everyone in the country, so that a genetic fingerprint found at the scene of a crime could instantly implicate that person. But who will have access to this information? There are concerns that a genetic database would be subject to misuse. If insurance companies had access to the genetic database, they might refuse insurance (or charge higher premiums) to people with an increased risk of, say, heart disease. Employers could (covertly) refuse employment to people because their ‘genetic profiles’ did not meet particular requirements. A recent ruling from the European court states that the police have no right to hold the DNA of someone unless they have been convicted of a crime.

But you should also consider the fact that biotechnology (including gene technology) is sometimes merely a refinement of less controversial practices. Organic farmers use the naturally occurring soil bacterium *Bacillus thuringiensis* as a non-chemical insecticide. Genetic engineers have extracted a gene from this bacterium and transferred it to cotton plants to make them resistant to attack by insects. Is there any real difference? People have known for centuries that rubbing a certain blue mould onto cuts can stop them turning septic. In 1922, Alexander Fleming discovered **penicillin** in the blue mould *Penicillium*.

#### KEY WORD

**penicillin** *the first antibiotic to be discovered*

### Activity 3.12: Different views about the use of DNA technology

Different groups of people have different viewpoints because of their cultural background and their previous experiences. For example, if you have a starving child or a child with a disease that may result in the death of the child unless DNA technology is used (to produce the crops or the drug) you will have a different attitude to a family who has never experienced this situation.

For some in big business the driving force is to make money to satisfy their shareholders. However, shareholders are people who often are concerned about ethical issues so even satisfying the shareholders isn't straightforward.

Other groups, such as animal liberationists, and some religious groups are against the use of animals in biotechnology without considering the benefits that come from such research as they consider that the welfare of the animal is paramount.

Some people's views are based on incorrect

knowledge or fear, but others have those views because they have knowledge that the ordinary consumer does not, for example they have seen a research laboratory where they think that animals are not looked after adequately.

Many genetically modified organisms are designed to be food for human consumption. The evaluation of the ethical issues can be decided on the arguments for and against the issues.

Design a poster using the information above to show how:

- a person from a biotechnology company
- a mother in a developing country
- an animal liberationist
- an informed 'man in the street'

might react to an announcement that a sheep that will produce 20% more meat has been developed as a result of genetic engineering.



## Review questions

Choose the correct answer from A to D.

- DNA consists of two polynucleotide strands in which:
  - the percentage of adenine is the same in each strand
  - the percentage of adenine is the same as that of thymine in each strand
  - the percentage of adenine is the same as that of thymine in the whole molecule
  - the percentage of adenine is 50% of that of thymine in the whole molecule
- Ligase is an enzyme that:
  - cuts DNA molecules, leaving sticky ends
  - joins sticky ends of DNA fragments
  - copies DNA fragments
  - separates DNA fragments
- A gene probe could be:
  - a short length of single-stranded DNA that has been made radioactive
  - a tRNA molecule that has been made radioactive
  - a short length of double-stranded DNA that has been made radioactive
  - all of the above
- Viruses and plasmids are examples of:
  - vectors
  - transformed bacteria
  - restriction enzymes
  - liposomes
- Which of the following statements about genetic fingerprinting is not accurate?
  - Genetic fingerprinting involves the analysis of the DNA to identify an individual.
  - Genetic fingerprinting can be used to identify criminals and also the real parents of a child when the identity is in doubt.
  - Only coding DNA is used to make a genetic fingerprint.
  - Genetic fingerprinting has become faster and more detailed over time.
- In gel electrophoresis of DNA:
  - the DNA fragments migrate towards the positive electrode and are separated according to their molecular mass
  - the DNA fragments migrate towards the negative electrode and are separated according to their molecular mass
  - the DNA fragments migrate towards the negative electrode and are separated according to their electric charge
  - the DNA fragments migrate towards the positive electrode and are separated according to their electric charge
- One advantage of genetic engineering over conventional selective breeding is that genetic engineering:
  - is quicker
  - has fewer side effects
  - cannot harm the environment
  - none of these
- The best definition of a transgenic organism is:
  - a bacterium that contains genes from another organism
  - a plant that has been genetically modified
  - an animal that has been 'pharmed'
  - any organism that has had a foreign gene added to its genome

## KEY WORDS

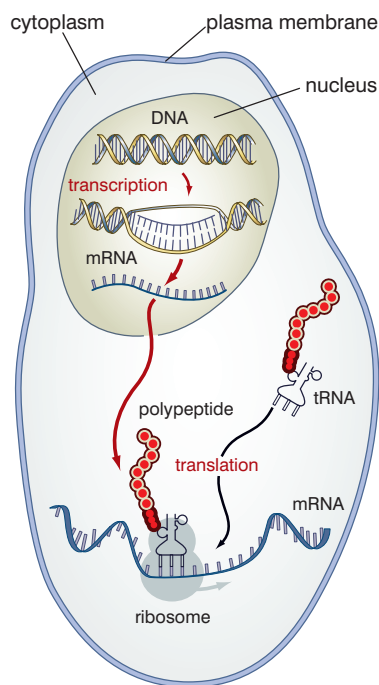
**mRNA (messenger RNA)** is a nucleic acid that transmits the genetic code from DNA to ribosome

**transcription** the process that converts genetic information from a DNA code into an mRNA code

**tRNA (transfer RNA)** transfers individual amino acids during translation

**ribosome** the part of a cell that makes proteins

**translation** the process in which the mRNA code is converted into a sequence of amino acids



**Figure 3.45** An overview of protein synthesis

## 3.3 Protein synthesis

By the end of this section you should be able to:

- Describe how the flow of information in a cell starts from the code on DNA and ends with proteins being synthesised.
- Understand the nature of the genetic code.
- Describe the roles of DNA, mRNA, tRNA and ribosomes in protein synthesis and understand the processes of transcription, translation and gene expression.
- Understand that protein synthesis depends on having a supply of amino acids which, in animals, come from the food they eat.
- Understand the different roles proteins have in cells and in the body.

## How does a cell 'know' to make a protein?

The code for a protein is specified by DNA and has to be carried to the ribosomes so that they can assemble the amino acids in the correct sequence to form the protein. However, DNA is a huge molecule and remains in the nucleus at all times. The following events occur:

- The DNA code for the protein is rewritten in a molecule of **messenger RNA (mRNA)**; this rewriting of the code is called **transcription**.
- The mRNA travels from the nucleus through pores in the nuclear envelope to the ribosomes.
- Free amino acids are carried from the cytoplasm to the ribosomes by molecules of **transfer RNA (tRNA)**.
- The **ribosome** reads the mRNA code and assembles the amino acids carried by tRNA into a protein; this is called **translation**.

Figure 3.45 summarises these processes.

## What is the genetic code like?

The genetic code is held in the DNA molecule. As you already know from your studies in grade 10, it is the sequence of bases in the nucleotides of the DNA that makes up a gene that codes for the protein and that each amino acid in the protein is coded for by a triplet (sequence of three) of bases. This gives us a useful definition of a gene:

*A gene is a sequence of base triplets in the DNA molecule that carries the code for a protein.*

With four different bases to work with (adenine, thymine, cytosine and guanine), there are 64 possible triplet codes, but only 20 amino acids are used to make all the different proteins. What is

the purpose of the other 44 codes? In fact, none of these is spare or redundant.

However, only *one* of the strands of the DNA molecule carries the code for proteins. This is called the coding strand or the sense strand. The other strand is the non-coding or antisense strand.

Most amino acids have more than one code. Only methionine and tryptophan have just one triplet that codes for them; arginine has six. Three of the triplets (TAA, TAG and TGA) do not code for amino acids at all. They are 'stop' codes that signify the end of a coding sequence. Because there is this extra capacity in the genetic code, over and above what is essential, it is said to be a degenerate code.

Besides being a triplet and degenerate code, the DNA code is a non-overlapping code. This means that each triplet is distinct from all other triplets. The last base in one triplet cannot also be the first base (or second base) in another triplet. This is illustrated in figure 3.46.

The genetic code is also a universal code. This means that the triplet TAT is the DNA code for the amino acid tyrosine in a human, a giant redwood tree, a bacterium or in any other living organism.

The 64 DNA triplets and the amino acids they code for are shown in two different ways in figures 3.47A and B. Notice the 'stop' codes.

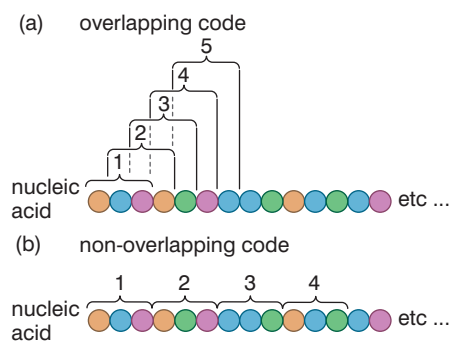
In this method of representing the genetic code, start with one of the 'biggest' letters in the centre. This represents the first base in the triplet. One of the four medium-sized letters in the next layer out represents the second base and the smallest letters represent the third base in the triplet. Outside that is the name of the amino acid for which the triplet codes.

So, ACC codes for threonine. GGG codes for glycine.

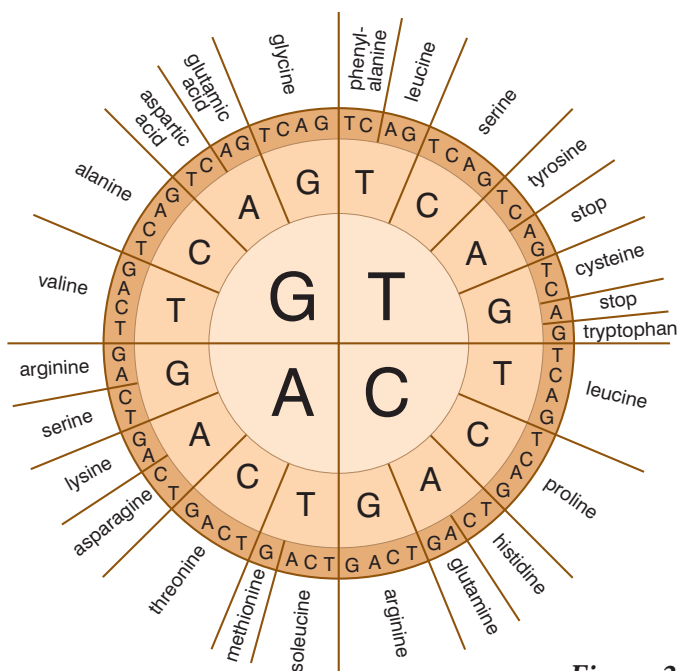
**DID YOU KNOW?**

**Order matters in the genetic code**

It is not just the actual bases in a triplet that matter, but also the sequence of bases within that triplet. So, the sequence ATT codes for a different amino acid to TTA.



**Figure 3.46** Overlapping and non-overlapping codes



**Figure 3.47A** The genetic code

		second position				
		T	C	A	G	
first position	T	phenylalanine	serine	tyrosine	cysteine	T
		leucine		stop	stop	A
	C	leucine	proline	histidine	arginine	T
				glutamine		A
A	isoleucine	threonine	asparagine	serine	T	
	methionine		lysine	arginine	A	
G	valine	alanine	aspartic acid	glycine	T	
			glutamic acid		A	
					G	G

Figure 3.47B Another way of representing the genetic code

**KEY WORDS**

**codon** a triplet of mRNA bases that has the code needed to make one protein

In this method of representing the genetic code, start with the letters at the left-hand side of the table. These represent the first base in the triplet. They define which row in the table to look in. The letters across the top represent the second base in the triplet and define which column in the table to look in. The letters at the right of the table represent the third base in the triplet and define which line in the row to look in. So, again, A (third row), C (second column) and C (second line) is the code for threonine and GGG the code for glycine.

**How does transcription take place in eukaryotic cells?**

During this process, the coded information in the DNA of one gene is used to synthesise a molecule of mRNA that will carry the code to the ribosomes. mRNA is similar to DNA in that it is built from nucleotides; however, it is different from DNA in a number of ways:

- it is a much smaller molecule
- it is single stranded
- the base thymine is replaced by uracil
- the sugar in the nucleotides is ribose, not deoxyribose

The triplets of bases in mRNA that code for amino acids are called **codons**. The mRNA codons are identical to the DNA triplets that code for specific amino acids, except that U (uracil) is substituted for T (thymine). To form the single-stranded mRNA when transcription takes place, only the antisense strand of DNA is transcribed. This is because the sense strand of this section contains

**Activity 3.13**

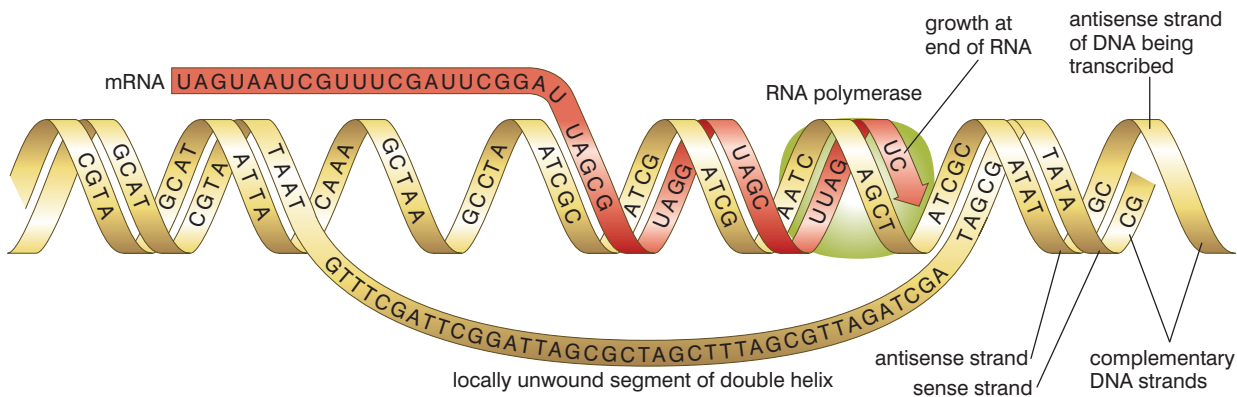
Protein synthesis is complicated. Produce a wall chart showing the stages of protein synthesis. It could be anything from a simple flow diagram to a complex series of images – but it must be clear and help with understanding and revision.

the gene that codes for a protein. However, transcribing this would produce a *complementary* sequence of bases, similar to those in the antisense strand, which would not code for anything.

In eukaryotic cells, transcription takes place in the following way:

- The enzyme DNA-dependent RNA polymerase (RNA polymerase) binds with a section of DNA next to the gene to be transcribed.
- Transcription factors (see later) activate the enzyme.
- The enzyme begins to ‘unwind’ a section of DNA. RNA polymerase moves along the antisense strand, using it as a template for synthesising the mRNA.
- The polymerase assembles free RNA nucleotides into a chain in which the base sequence is complementary to the base sequence on the antisense strand of the DNA. This, therefore, carries the same triplet code as the sense strand (except that uracil replaces thymine).

**Figure 3.48** Transcription in eukaryotic cells



- The completed molecule leaves the DNA; the strands of DNA rejoin and re-coil.

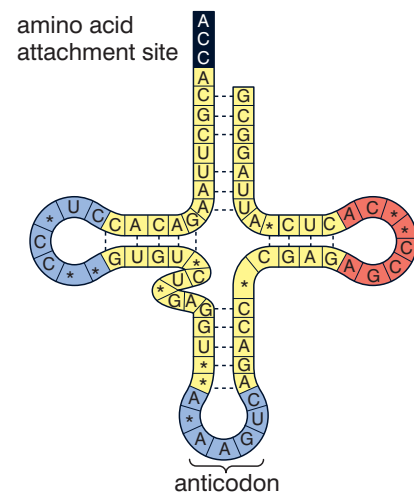
The mRNA molecule now contains the code for the protein that was held in the DNA of the gene.

### How does translation take place?

Translation of the mRNA code into a protein depends on the interaction within a ribosome between mRNA and tRNA. All tRNA molecules have the same basic structure. The ‘cloverleaf’ configuration of the molecule has at one end a triplet of bases called an anticodon. This anticodon will be complementary to one of the mRNA codons. The other end of the tRNA molecule has an attachment site for the amino acid that is specified by the mRNA codon.

Ribosomes are made from ribosomal RNA (rRNA) and proteins organised into a large and a small subunit. Within the ribosome, there are three sites that can be occupied by a tRNA molecule, called the A, P and E sites. The following events take place:

- The first two codons of the mRNA enter the ribosome.
- Transfer RNA molecules (with amino acids attached) that have



**Figure 3.49** The structure of tRNA

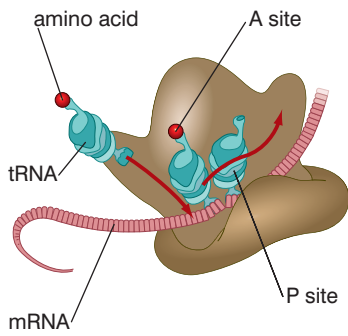


Figure 3.50 The structure of a ribosome

complementary anticodons to the first two codons of the mRNA bind to those codons.

- A peptide bond forms between the amino acids carried by these two tRNA molecules and the dipeptide is transferred to the tRNA in the A site.
- The ribosome moves along the mRNA by one codon, bringing the third codon into the ribosome; at the same time the ‘free’ tRNA exits the ribosome and the tRNA with the dipeptide moves into the P site.
- A tRNA with a complementary **anticodon** binds with the third codon, bringing its amino acid into position next to the second amino acid.
- A peptide bond forms between the second and third amino acids.
- The ribosome moves along the mRNA by one codon, bringing the fourth mRNA codon into the ribosome, and the whole process is repeated until a ‘stop’ codon is in position and translation ceases.

**KEY WORD**

**anticodon** a triplet on tRNA complementary to a codon in mRNA

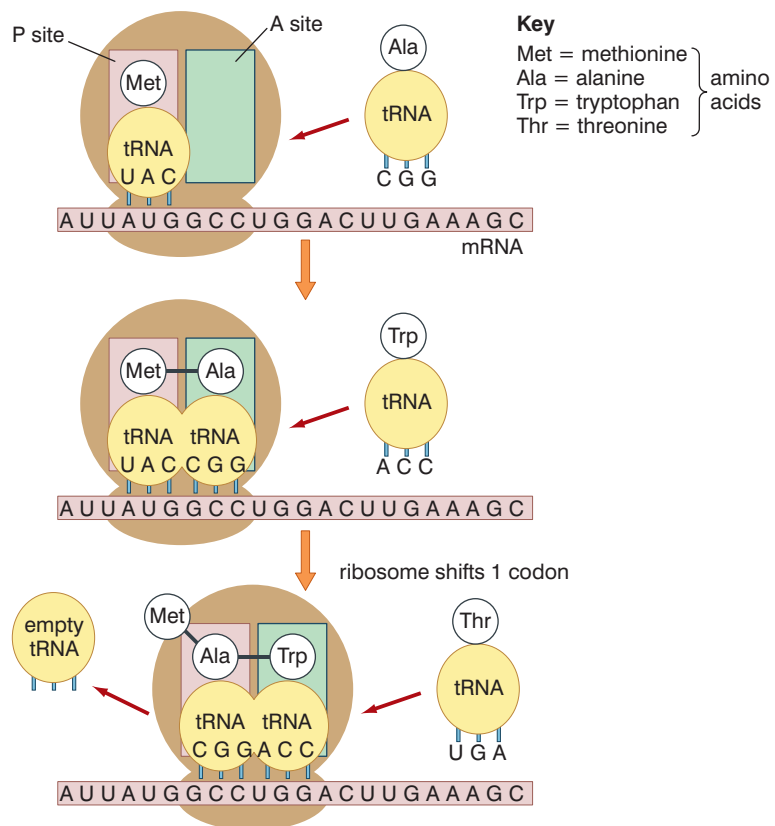


Figure 3.51 Translation

The translation of the mRNA code into a protein molecule requires energy. However, this does not come from the hydrolysis of ATP as is usual in a cell, but from the hydrolysis of a similar molecule, GTP – Guanosine Triphosphate. It is hydrolysed to GDP and P<sub>i</sub> in the same way as ATP, with the release of a small amount of energy.

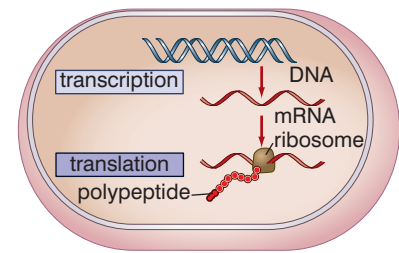
## How is protein synthesis different in prokaryotic cells?

The process is essentially similar in both types of cells, with DNA being transcribed to mRNA, which is then translated to a polypeptide chain. However, there are some differences and these are linked to the fact that:

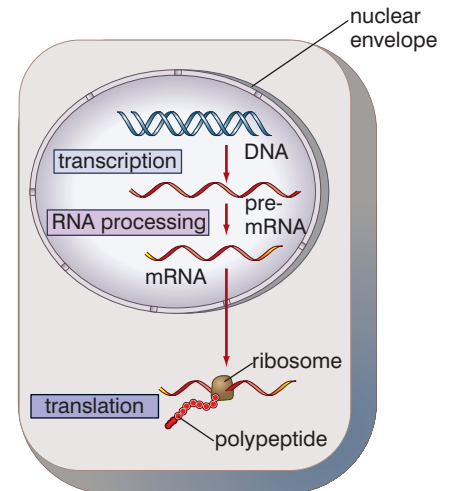
- prokaryotic cells do not have a nucleus
- prokaryotic mRNA does not need post-transcriptional processing
- prokaryotes: transcription and translation are coupled; mRNA can be translated by ribosomes at one end of its molecule while it is still being transcribed from DNA at the other end
- eukaryotes: transcription and translation are separated
- transcription occurs in the nucleus
- translation occurs in the cytoplasm
- eukaryotic mRNAs are modified before leaving the nucleus

## What becomes of the proteins that are synthesised?

All our proteins are synthesised in the way just described, but all our cells do not synthesise all our proteins as we shall see in the next section. However, we synthesise a vast array of different proteins that we can categorise, broadly, into the types shown in table 3.2.



(a) prokaryotic cell



(b) eukaryotic cell

**Figure 3.52** Protein synthesis in prokaryotic and eukaryotic cells

**Table 3.2** Some of the proteins our body synthesises

Type of protein	Example	Function of example
Structural	Collagen	Building fibres of cartilage
	Keratin	Building nails and feathers
Enzyme	ATP synthase	Producing ATP from ADP and P <sub>i</sub>
	DNA helicase	Unwinding the double helix of DNA
Peptide hormone	Insulin	Control of plasma glucose concentration
	Adrenaline (epinephrine)	Fight or flight response
Antigen	A antigen on red cells	Determine blood group
	CD4	Allows binding of HIV to T-lymphocytes
Antibody	Anti-a antibodies	Causes clotting of red cells with A antigen
	HIV antibodies	Destroys some HIV antigens

To synthesise these proteins continually, our bodies require a constant supply of amino acids. These we obtain from the protein in the foods we eat. The average adult protein requirement per day is about 50 grams. The proteins are hydrolysed to amino acids in our gut and absorbed into the blood plasma by active transport. They are then transported to the cells where they are used to synthesise our proteins.

**KEY WORD**

**amino acid** the 'building block' of proteins; each amino acid has an 'amino' group and a 'carboxyl' (acid) group

As mentioned earlier, just 20 amino acids are used to make all the different proteins. Some of these can be made in our bodies by a process called transamination. In this process, the amino group of an **amino acid** is removed and transferred to a keto acid. The keto acid then becomes a different amino acid and what was the amino acid becomes a keto acid. Figure 3.53 illustrates this.

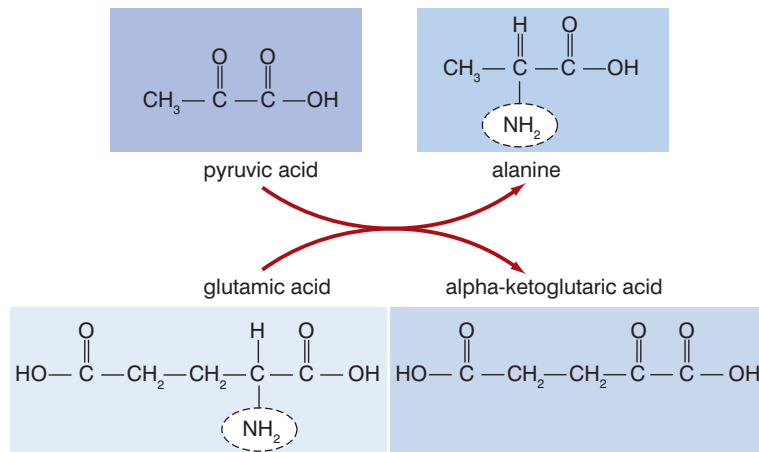


Figure 3.53 Transamination

Not all amino acids can be produced by transamination. There are some that we just have to obtain from our food. These amino acids are called essential amino acids (although they are all essential really).

Meat, fish, poultry, eggs and milk are animal sources of protein that provide a good balance of all eight essential amino acids. The best non-animal sources are quinoa, buckwheat, hempseed and amaranth, although these contain lower overall amounts of protein than some cereals (wheat, rice, maize) and nuts and pulses.

**What controls gene expression?**

The fact that some genes are sex-limited tells us that all genes aren't active all the time. There are more examples of this – the genes that control the colour of your iris are present in all your cells, but all your other cells aren't this colour – just the iris. Somehow, we can control which genes are active where.

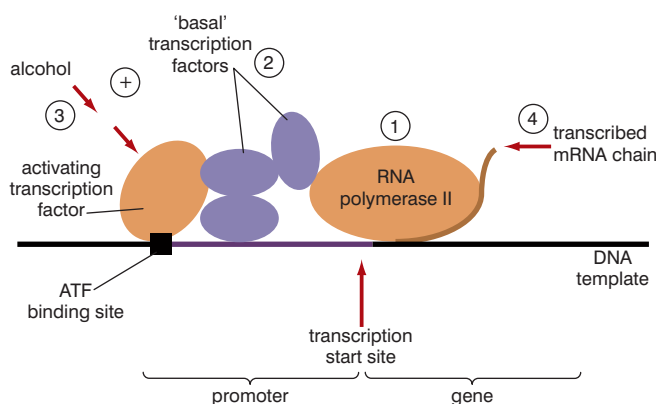


Figure 3.54 How some transcription factors act

**How are genes switched on?**

Very often, genes are switched on by 'transcription factors' that are present in the cell. These transcription factors are usually proteins that bind to a regulatory sequence of DNA near to the gene they influence. They operate in the following way:

- The transcription factors bind to a promoter sequence of DNA near to the gene to be activated.
- RNA polymerase binds to the DNA/transcription factor complex.



- The RNA polymerase is 'activated' and moves away from the DNA/transcription factor complex along the gene.
- The RNA polymerase transcribes the antisense strand of the DNA as it moves along; the gene is now being expressed.

**Think about it – where do the transcription factors come from?**

If the transcription factors are proteins themselves, then they must be synthesised as a result of gene expression, and some other genes must regulate the expression of these genes. Biologists think that this goes all the way back to the egg cell itself, which is able to synthesise a certain number of transcription factors. These are made once the egg is fertilised to become a zygote and are passed on to the cells formed when the zygote divides. They influence the cells formed and these cells produce other transcription factors, which are, in turn, passed on to the next generation of cells and so on. This 'cascade' or 'hierarchy' of transcription factors results in each cell having only certain transcription factors that can activate certain genes.

**DID YOU KNOW?**

**Some cancers are caused by hormones acting as transcription factors**

Oestrogen is a steroid hormone that can diffuse through the plasma membrane of a cell. It binds with a receptor in the cytoplasm. The oestrogen-receptor complex moves into the nucleus and binds with and activates specific genes. In the breasts, and lining of the uterus, the activated genes cause cell division.

Many breast cancers are said to be oestrogen-receptor positive. This means that the cancer cells have oestrogen receptors to which the hormone can bind, causing the same increase in cell division as it does in normal breast tissue. The anti-cancer drug tamoxifen can bind with the oestrogen receptors and the tamoxifen/receptor complex binds with the DNA. However, tamoxifen does not allow transcription factors to bind and so expression of the genes is prevented, and cell division in the cancer is slowed.

**How are genes switched off?**

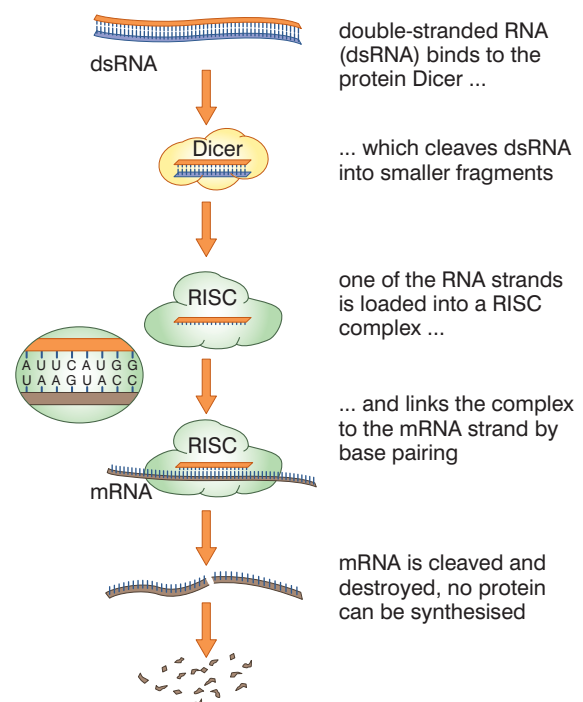
Besides transcription factors that promote the expression of genes, other factors can act to repress gene action. One group of substances that does this is known as **short interfering RNA (siRNA)**. These RNA molecules are unusual because they are very short – only about 21 to 23 nucleotides long – and are double stranded.

They don't act on the gene itself, but they 'interfere with' or 'silence' the mRNA once it has been transcribed from the DNA. This is called post-transcriptional interference. If the mRNA is prevented from translating its codons into amino acids, then the protein for which the gene codes cannot be built. The gene has effectively been silenced.

Biologists think that the action of siRNA is as follows:

- Double-stranded RNA (dsRNA) is produced in the nucleus from a range of genes.
- It is then split into the very short lengths that characterise siRNA by an enzyme called 'Dicer'.

The RNAi mechanism  
RNA interference (RNAi) is an important biological mechanism in the regulation of gene expression



**Figure 3.55 Gene silencing**

**KEY WORD**

**short interfering RNA** *a short sequence of RNA which can be used to silence gene expression*

**DID YOU KNOW?**

**Biologists think that siRNAs hold a great deal of promise to treat AIDS and some cancers**

Researchers have already shown that they can use siRNA to prevent the replication of HIV in cultures by silencing either some of the genes of the virus or some of the human genes on which it depends.

Other researchers have shown that they can silence genes associated with cancer. If oncogenes could be silenced effectively, then a new treatment for many cancers is possible.

- The antisense strand of the siRNA then binds with a complex of molecules called RISC.
- The siRNA binds with mRNA and allows RISC to degrade/cleave the mRNA into small fragments.

**Review questions**

Choose the correct answer from A to D.

- tRNA differs from DNA because it is:
  - smaller, single stranded and shows no base pairing
  - smaller, single stranded with thymine replaced by uracil
  - smaller, single stranded and with deoxyribose instead of ribose
  - smaller, single stranded and linear in shape
- The genetic code is:
  - a triplet code, degenerate and overlapping
  - a doublet code, degenerate and universal
  - a doublet code, degenerate and non-overlapping
  - a triplet code, degenerate and universal
- The DNA triplet AAT would code for an amino acid carried by tRNA with the anticodon:
  - AAU
  - TTA
  - AAT
  - UUA
- In a ribosome, when the two amino acids that are held adjacent to each other form a peptide bond, the tRNA molecules are in the:
  - A and P sites
  - A and E sites
  - E and P sites
  - none of the above
- Post-transcriptional modification of mRNA is carried out in order to:
  - remove exons
  - remove introns
  - alter its shape so that it can bind with a ribosome
  - alter its shape so that it can bind with an amino acid

6. Which of the following statements about transcription factors is correct?
- A They are always produced within cells.
  - B They bind with promoter sequences of DNA next to the gene.
  - C They are the same in all cells.
  - D All of the above.
7. Gene silencing by siRNA is referred to as a form of post-transcriptional repression because:
- A it stops transcription of genes by RNA polymerase
  - B it only allows certain genes to be expressed
  - C it destroys the mRNA formed by transcription of a gene
  - D none of the above
8. Essential amino acids:
- A must be taken in as part of our diet
  - B cannot be synthesised by transamination
  - C are found in large amounts in quinoa, meat and buckwheat
  - D all of the above
9. When comparing protein synthesis in eukaryotic cells and prokaryotic cells it is correct to say that transcription and translation are:
- A separate in both
  - B coupled in both
  - C separate in prokaryotes and coupled in eukaryotes
  - D separate in eukaryotes and coupled in prokaryotes
10. Which of the following statements about transcription is correct?
- A RNA polymerase assembles DNA nucleotides into a single strand.
  - B RNA polymerase assembles DNA nucleotides into a double strand.
  - C RNA polymerase assembles RNA nucleotides into a double strand.
  - D RNA polymerase assembles RNA nucleotides into a single strand.

### 3.4 Mutations

By the end of this section you should be able to:

- Explain what is meant by the term mutation.
- Describe some of the different types of mutations.
- Describe and explain some of the causes of mutations.
- State the spontaneity of a mutation.
- Describe and explain some of the consequences of mutations.
- Give examples of inheritable mutations.

#### KEY WORD

**mutation** *a random change in genetic information*

#### What are mutations?

A **mutation** is any spontaneous change in the genetic material of an organism. There can be large structural changes involving whole chromosomes or parts of chromosomes, or changes that involve only a single base. The changes involving only a single base are called point mutations, and it is these that we are mainly concerned with.

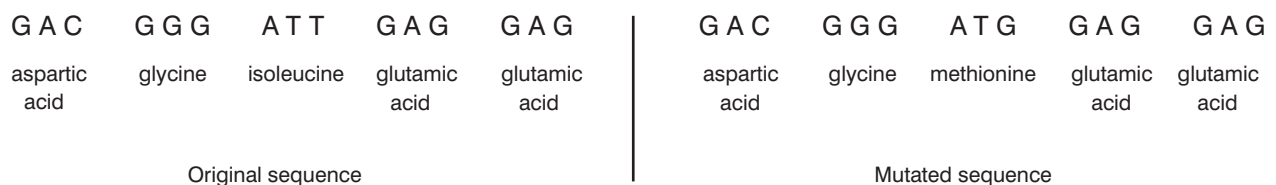
There are several types of point mutation, in which one of the bases in the DNA sequence of a gene is altered, usually by being copied wrongly when the DNA replicates. The different point mutations are:

- substitution
- addition
- deletions

These mutations occur quite randomly when DNA is replicating and each involves a change to just one base, but the change to the gene can be dramatic and the result can be that the protein the gene should code for is not made at all or a different protein is made.

#### Substitution

In substitution mutations, one base is replaced by a different base, as shown in figure 3.56.



**Figure 3.56** A substitution mutation

Guanine replaces thymine in this substitution. The triplet ATT has been changed to ATG (no other triplet is affected). The original triplet, ATT, codes for the amino acid isoleucine. However, the new triplet, ATG, codes for methionine. As a result, a different protein

will be synthesised, which may or may not be significantly different from the original. One different amino acid in a protein does not always make a functional change. If the substitution had been by any base other than guanine, because the DNA code is degenerate, (see figures 3.47A and B) the triplet would still have coded for isoleucine and the same protein would have been synthesised. Effectively, it would still have been the same gene.

Other substitutions can result in a 'stop' triplet, as shown in figure 3.57. In this case transcription ceases when it reaches the stop code and a non-functional mRNA results.

**KEY WORD**

**sickle-cell anaemia** a condition caused by a mutation that affects the structure of the haemoglobin molecules in red blood cells causing the red blood cells to sickle under low oxygen tension

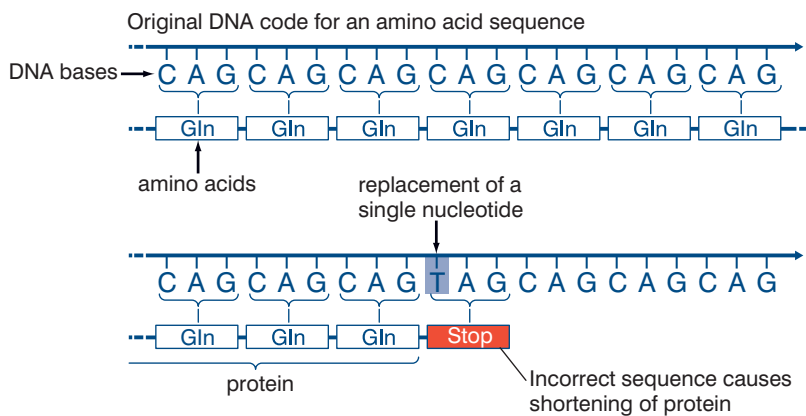


Figure 3.57 A nonsense substitution.

**DID YOU KNOW?**

A substitution of just one base in the sixth triplet of the gene coding for one of the four polypeptides in the haemoglobin molecule alters the triplet from GAG to GTG. This results in the amino acid valine replacing glutamate in the polypeptide chain. The different haemoglobin molecule formed results in the condition known as **sickle-cell anaemia**.

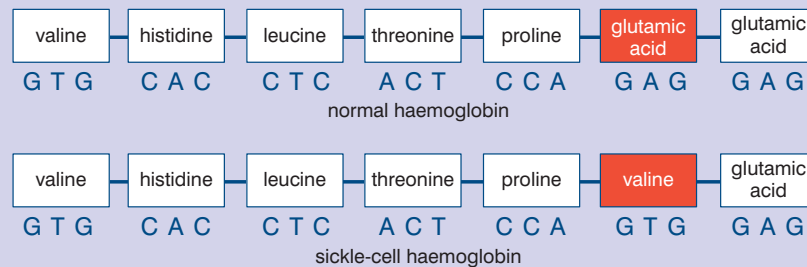
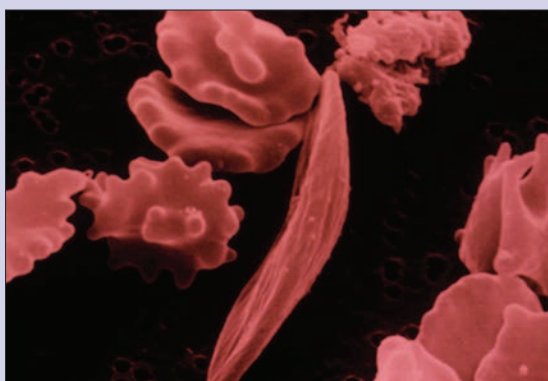


Figure 3.58 The mutation that causes sickle-cell anaemia



If a person inherits two copies of the mutated gene, then all of their red blood cells will contain the abnormal haemoglobin that causes the red blood cells to collapse into sickle-shaped cells under conditions of low oxygen concentration. The sickled cells often fracture and stick together and block capillaries.

Figure 3.59 Sickle-cell anaemia

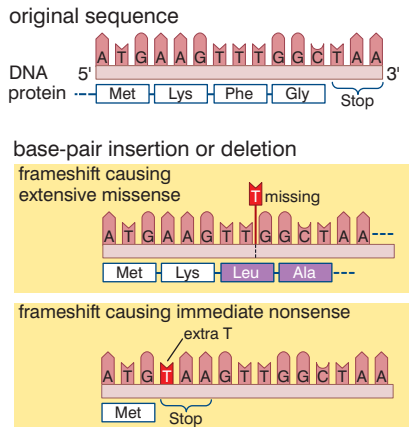


Figure 3.60 Frameshift mutations

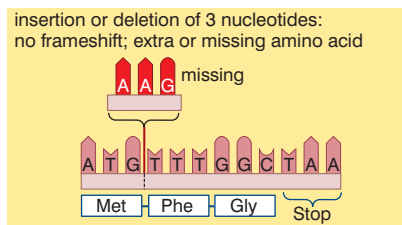


Figure 3.61 Deletion of an entire triplet

**KEY WORD**

**deletion mutation** a mutation caused by one DNA nucleotide being omitted from the sequence

**Addition and deletion**

In a **deletion mutation** a base is ‘missed out’ during replication, whilst in additions, an extra base is added. Both these are more significant mutations than substitutions. Substitutions affect just one triplet and, because the DNA code is degenerate, may well have no overall effect – the same protein may still be produced. This can never be the case with additions and deletions.

The reason for this is that they do not just alter the triplet in which the mutation occurs. Because there is one fewer or one extra base, the whole sequence after the point of the mutation is altered. We say that there has been a frameshift and these are frameshift mutations. A totally different mRNA is produced (if one is produced at all) and a non-functional protein or no protein at all.

Sometimes, a whole triplet is missed out or inserted. This will result in either one extra or one fewer codon in the mRNA. In turn, this will lead to one extra or one fewer amino acid in the polypeptide chain.

**Another way of thinking about frameshifts**

Look of this sequence of letters:

THEMANWASHOTANDRANFORHISHAT

If we give this a ‘reading frame’ of three letters, it becomes:

THE MAN WAS HOT AND RAN FOR HIS HAT

and it makes sense. But if we take out the S at the end of WAS (a deletion mutation), it becomes:

THE MAN WAH OTA NDR ANF ORH ISH AT

In other words it no longer makes sense. In genetic terms it is **mis-sense** coding

**What causes point mutations?**

Mutations occur spontaneously and randomly – they are accidents that occur when DNA is replicating. Mistakes happen. Mutations are rare events, which is quite surprising when you consider that each cell contains  $6 \times 10^9$  (six billion) base pairs that might mutate! Biologists estimate that mutations arise at the rate of 1 in  $50 \times 10^6$  (one in fifty million) base pairs. This means that each new cell will have, on average, 120 mutations. This sounds rather worrying, but you should remember two things:

- most of these mistakes (mutations) are detected and repaired, and
- because 95% of our DNA is non-coding, most mutations are unlikely to affect coding genes.

The rate of mutation can be increased by a number of factors including:

- carcinogenic chemicals, for example, those in tobacco smoke
- high-energy radiation, for example, ultraviolet radiation, X-rays

## What are the consequences of gene mutations?

There are a number of factors that influence the answer to this, but, really, two important ones:

- which cells, and
- which genes?

Mutations that occur in a normal body cell (a non-sex cell) will have one of four possible consequences:

- It will be completely harmless.
- It will damage the cell.
- It will kill the cell.
- It will make the cell cancerous, which might kill the person.

Whichever of these is the case, the mutation will affect no other person; it will not be passed on to the next generation. However, if the mutation occurs in a sex cell, or a cell that will divide to give rise to a sex cell, then it may be passed on to the next generation.

Mutations in different genes will obviously produce different effects, but two types of genes are really important. Genes called proto-oncogenes and tumour suppressor genes play important roles in regulating cell division and preventing the formation of a **tumour**. When proto-oncogenes mutate, they often become active oncogenes, which stimulate the cell to divide in an uncontrolled manner. Ordinarily, some growth factor would be necessary to make the cell divide.

Tumour suppressor genes recognise uncontrolled cell division and act to suppress cell division. If these genes mutate and become inactive, a tumour will form as uncontrolled cell division continues.

### KEY WORDS

**tumour** a tumour is a mass of cells created when cell replication gets out of control. Tumours cause the disease cancer

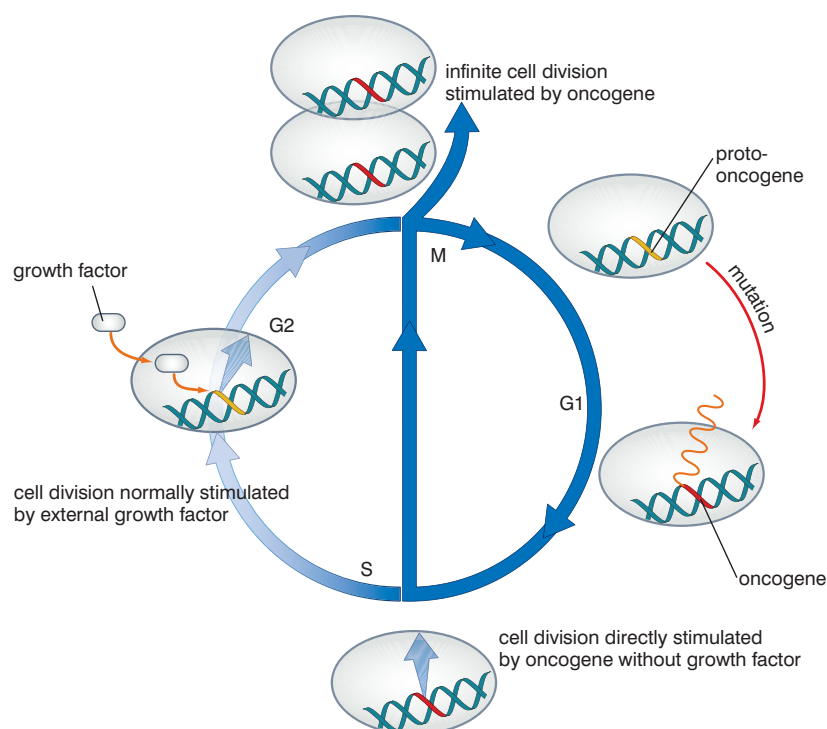


Figure 3.62 How a tumour starts

### Can mutations benefit an organism?

So far, we have talked only about how mutations produce harmful effects, but mutations are the raw material of evolution. It is the only process that creates new genes. Crossing over, segregation and random assortment in meiosis together with random fusion in fertilisation reshuffle existing genetic material, but only mutation produces new genetic material.

If a mutated allele gives an organism an advantage then Natural Selection will act so that frequency of that allele increases with successive generations. As it does the numbers of the organism with the mutated allele will also increase, at the expense of those without it.

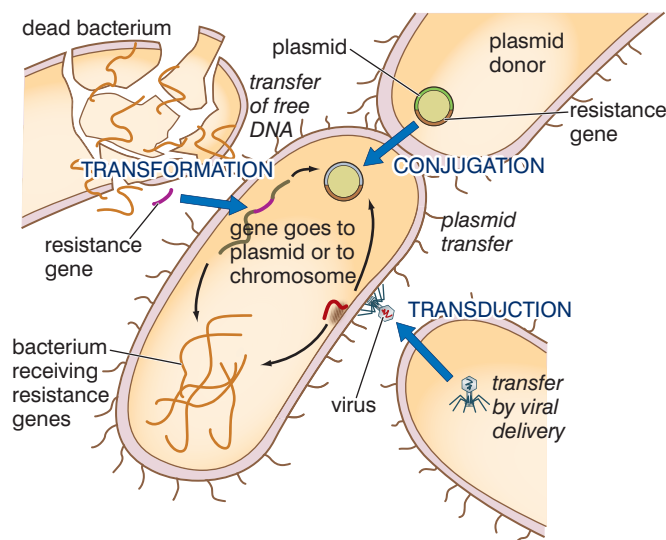
Mutations in the DNA of bacteria can give them resistance to a specific antibiotic, such as penicillin or ampicillin. These mutations arise spontaneously, as do all mutations. They only give the bacterium an advantage if the particular antibiotic is actually being used. Being resistant to streptomycin is no advantage if penicillin is being used. But being resistant to penicillin in an environment where penicillin is widely used confers a considerable advantage to the organisms. In 1947, just four years after penicillin was used widely in the USA, the first penicillin-resistant bacterium was found – it was a bacterium called *Staphylococcus aureus*. Today over half the infections caused by *Staphylococcus aureus* are caused by penicillin-resistant types.

#### KEY WORDS

**antibiotic resistance** *the evolution of strains of bacteria that are not affected by antibiotics. It is caused by the overuse of antibiotics*

Bacteria can also ‘swap’ **antibiotic resistance** genes with each other. Most of the mutant genes that confer resistance are found in the plasmids – the ‘extra’ small circular pieces of DNA that are separate from the main bacterial DNA. They can transfer these plasmids to other bacteria by:

- conjugation – the plasmid passes through a special ‘conjugation’ tube from one bacterium to another
- transduction – a virus carries the plasmid from one to another
- transformation – the plasmid is absorbed from a dead bacterium



**Figure 3.63** Transfer of antibiotic resistance between bacteria



## Chromosome mutations

Chromosome mutations occur when there is any change in the arrangement or structure of the chromosomes. They occur most often during meiosis at crossing over in prophase 1. There are several different mutation types that result in a change in the structure of a chromosome. They are much bigger events than point mutations and usually result in the death of a cell. They may also affect the whole organism. For example, if essential parts of the DNA are affected by chromosomal mutations, a foetus may be aborted.

### Inversion

This occurs when an area of DNA on a chromosome reverses its orientation on the chromosome. Just one inversion on chromosome 16 can cause leukemia. An inversion that leads to an embryo having too few or too many copies of genes, can cause the embryo to miscarry, fail to grow, or be born with substantial medical problems.

### Deletion

With this cause of mutation, a decrease in the number of genes occurs due to the deletion of a large section of a chromosome. Deletion can result in a variety of genetic disorders, such as Prader-Willi syndrome. This results from a malfunction of the hypothalamus (a small endocrine organ at the base of the brain), which plays a crucial role in many bodily functions, including hunger and satiety, temperature and pain regulation, fluid balance, puberty, emotions and fertility.

### Insertion

This type of mutation describes an increase in the number of genes caused when an unequal crossover happens during meiosis. The chromosome may become abnormally long or short and stop functioning as a result.

### Duplications

When genes are duplicated it results in them being displayed twice on a single chromosome. This is usually harmless as the chromosome still has all its genes. However, duplication of the whole chromosome is more serious. Having three copies of **chromosome 16**, known as trisomy 16, leads to babies being born with a range of medical issues, such as poor foetal growth, muscular and skeletal anomalies, congenital heart defects and underdeveloped lungs.

### Chromosome non-disjunction

When homologous chromosomes do not separate successfully to opposite poles during meiosis, the result is one of the gametes lacking a chromosome and the other having an extra chromosome. If this happens with **chromosome 21**, Down's syndrome results. Those with the condition will have 47 chromosomes in every cell

#### KEY WORDS

**Chromosome 16** one of the 23 pairs of chromosomes in humans. It spans about 90 million base pairs and accounts for nearly 3% of DNA in cells

**Chromosome 21** one of the 23 pairs of chromosomes in humans. It is the smallest of the chromosomes

**Activity 3.14**

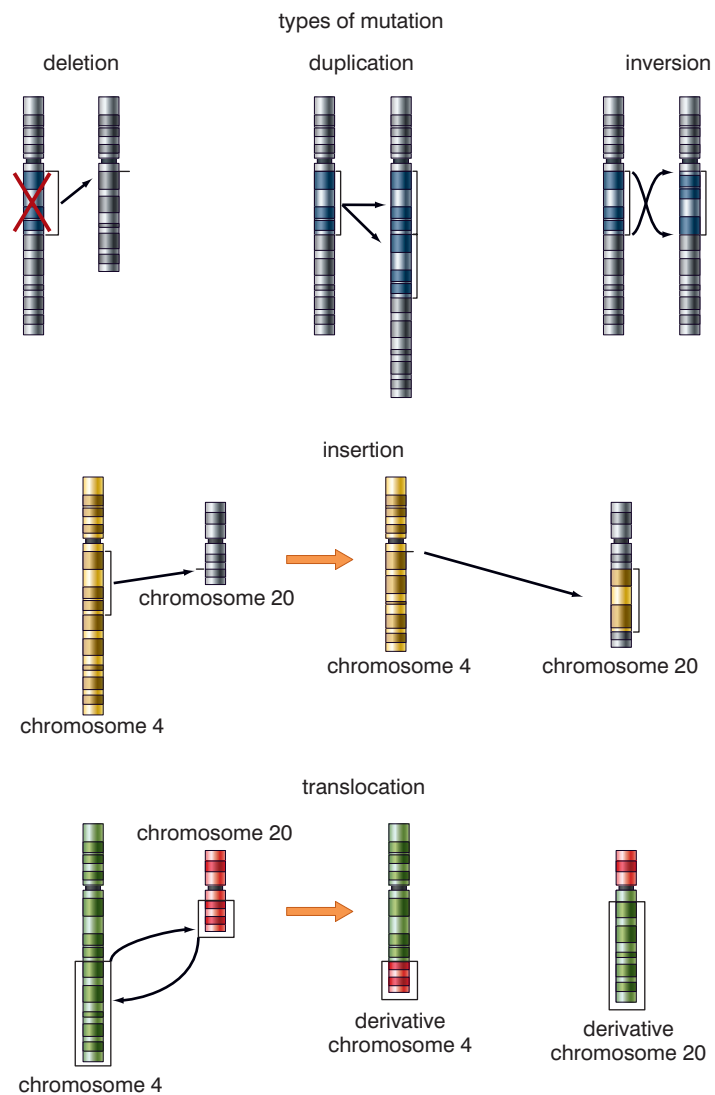
Mutation is very important. It can cause genetic diseases, but it is also needed for natural selection and evolution to take place. Work in a group, discuss all aspects of mutation. Develop a poster using a large spider diagram to show everything you have discussed. Include with simple facts about mutation and what causes it in one area of the diagram, positive benefits of mutation in another and the damaging aspects of mutation in a third area. Think of inventive ways to highlight these different regions of your diagram so it is easy for others to see them.

(because they have three copies of chromosome 21) as opposed to 46 like normal. Down's syndrome is characterised by mental retardation, heart defects and stunted growth.

**Translocations**

A piece of one chromosome is transferred to another non-homologous chromosome. This type of chromosome mutation is often responsible for chronic myelogenous leukemia.

These chromosomal mutations are illustrated in figure 3.64.



**Figure 3.64** Chromosomal mutations

## Review questions

Choose the correct answer from A to D.

- Which of the following is an example of a chromosomal mutation:
  - a base duplication
  - a base insertion
  - a translocation
  - none of these
- Which of the following is a frameshift mutation?
  - point replacement
  - Inversion
  - Insertion
  - substitution
- The only source of new genetic material during evolution is:
  - crossing over
  - segregation
  - random assortment
  - mutation
- The increase in bacterial resistance to penicillin is due to:
  - mutation
  - natural selection
  - the increased use of penicillin
  - a combination of all the above
- If a substitution occurs in the DNA of an organism, which of the following will also occur?
  - The mRNA will also be altered.
  - All the triplets after the mutation will be altered.
  - All the triplets before the mutation will be altered.
  - A frameshift will occur.

## Summary

In this unit you have learnt that:

- Genes are sections of DNA in a chromosome that determine a particular feature.
- Alleles are different 'versions' of a gene (for example, pea plants have purple and white alleles of the gene for flower colour).
- Homologous chromosomes carry alleles of the same genes at the same loci.
- Dominant alleles are expressed in the homozygote and in the heterozygote; recessive alleles are only expressed in the homozygote.
- Some alleles are codominant; both alleles are expressed in the heterozygote.
- In multiple allele inheritance, there are more than two alleles of a gene in the population as a whole, but any individual still has only two alleles.

- Meiosis produces four haploid cells that show genetic variation; the variation is a result of:
  - crossing over in prophase I
  - independent assortment of the chromosomes at anaphase I and anaphase II
- In dihybrid inheritance, a cross between two individuals heterozygous for both traits produces a 9:3:3:1 ratio in the offspring, if the genes are not linked.
- Some genes show linkage and are inherited as though they were a single unit; this is because their loci are on the same chromosome.
- Crossing over in meiosis produces recombinant types in the offspring; the frequency of these recombinant types can be used to measure how far apart the genes are on the chromosome.
- Gender, in humans, is determined by the X and Y chromosomes; males have the genotype **XY** whilst that of females is **XX**.
- Some conditions are determined by alleles carried on the sex chromosomes; these are called sex-linked conditions.
- Most sex-linked conditions are determined by recessive alleles on the X chromosome; males are affected more frequently than females by these because they need only inherit one X chromosome with the recessive allele whilst females must inherit two.
- Cross-breeding and inbreeding are both important techniques in agriculture; cross-breeding results in hybrid vigour (heterosis) and can be used to combine desirable traits in one variety, whilst inbreeding is used to establish pure lines.
- The DNA molecule is a double helix in which the base sequence on the sense strand is complementary to the base sequence on the antisense strand.
- The genetic code is a triplet, degenerate, non-overlapping and universal code.
- When compared with DNA, mRNA is smaller, single stranded (not double stranded), contains ribose (not deoxyribose) and contains uracil instead of thymine.
- The genome of an organism is the complete set of genetic information in that organism.
- A transgenic organism has had genes from a different type of organism (usually a different species) added to its genome.
- Restriction enzymes cut DNA at specific sequences, called restriction sites, to leave overlapping, sticky ends.

- A gene is inserted into a plasmid using a ligase enzyme.
- If insufficient DNA is obtained, the amount can be amplified using the polymerase chain reaction.
- Genetically modified organisms can be used to manufacture specific products to benefit humans (for example, insulin, bovine somatotrophin and vaccines).
- Other organisms have also been genetically modified to produce increased yields.
- In genetic fingerprinting:
  - a DNA sample is cut into fragments by restriction enzymes
  - the fragments are denatured by separating the two strands
  - the fragments are separated by gel electrophoresis and transferred to a nylon membrane by Southern blotting
  - a radioactive gene probe is added to the membrane and the pattern of complementary sequences is revealed using X-ray film
- In the transcription of the DNA in a gene RNA polymerase uses RNA nucleotides to build the single-stranded mRNA molecule that has a base sequence complementary to the strand of DNA being transcribed.
- During translation of mRNA into a polypeptide chain, tRNA molecules with anticodons complementary to the mRNA codons inside the ribosome bind to the mRNA; their amino acids form a peptide bond and one of the tRNA molecules leaves and the process is repeated.
- The proteins produced have a variety of functions: they may be structural proteins, enzymes, peptide hormones, antigens and antibodies, for example.
- Transcription factors are necessary to activate genes; these are proteins that bind with the promoter regions next to a gene and allow RNA polymerase to transcribe the gene.
- Molecules of short interfering RNA (siRNA) can 'silence' genes by degrading the mRNA transcribed from the genes.
- siRNA has the potential to treat conditions such as AIDS by preventing replication of HIV, and cancers by silencing genes that enhance cell division.
- Point mutations are spontaneous changes in a single base on the DNA molecule.
- Substitutions replace one base with another; because the code is degenerate, there may be no change in the amino acid coded for.
- Deletions and additions both cause a frameshift; these mutations alter all the DNA triplets after the point of mutation and change all the amino acids after this point also.

- High-energy radiation and carcinogenic chemicals increase the rate of mutation.
- If proto-oncogenes mutate to become active oncogenes, they will stimulate the cell to divide in an uncontrolled manner.
- If tumour suppressor genes mutate and fail to regulate cell division, a tumour may form.
- Mutations can be inherited; if a mutation is beneficial the frequency of the mutated allele will increase in successive generations.

### End of unit questions

- (a) Describe the structure of the DNA molecule. You may use a diagram to help if you wish.
  - (b) Describe three ways in which a molecule of mRNA is different from DNA.
  - (c) Describe two ways in which a molecule of tRNA is different from mRNA.
- A sequence of bases on a strand of DNA is:

A T T C C C G C T A A A C A G

  - (a) What is the sequence of bases of the mRNA molecule that could be formed from this strand?
  - (b) Use this sequence to explain what is meant by:
    - (i) a deletion mutation
    - (ii) a substitution mutation
- Protein synthesis is divided into two stages: transcription and translation.

  - (a) Describe how transcription takes place in a eukaryotic cell.
  - (b) Describe three ways in which protein synthesis in a prokaryotic cell differs from protein synthesis in a eukaryotic cell.
- Flower colour in pea plants is controlled by a single gene with two alleles. The allele for purple flowers is completely dominant over the allele for white flowers.

  - (a) Explain what is meant by the following terms:

gene

allele

dominant
  - (b) How could you find the genotype of a purple-flowered plant of unknown parents? Explain your answer.

5. Andalusian fowl can have plumage with have three distinct colours:

- black
- white
- blue

In breeding experiments, the following results were obtained:

Parents	Black x White	Blue x Blue
Offspring	All blue	1 black : 2 blue : 1 white

- (a) Suggest an explanation for these results. Use evidence from the crosses to support your explanation.
- (b) If a blue fowl were bred with a white fowl, what offspring would you expect? Explain your answer.

6. The pedigree in figure 3.65 shows the inheritance of red-green colour blindness in one family over four generations.

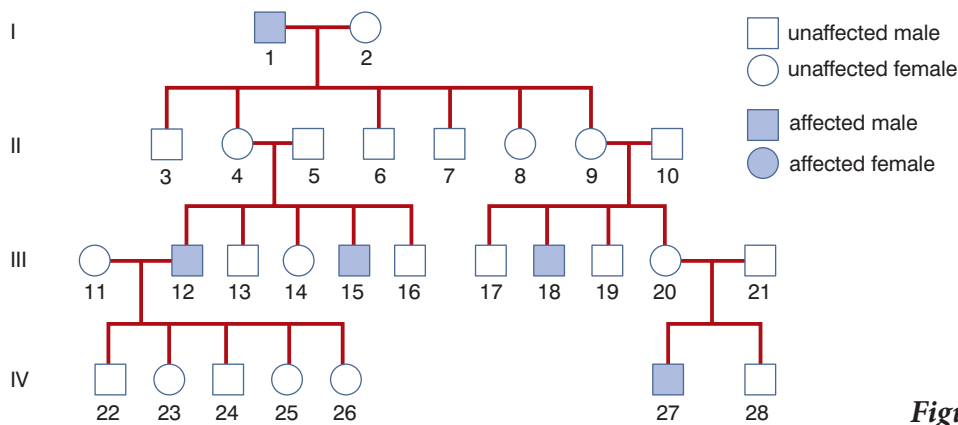


Figure 3.65

- (a) What evidence in the pedigree suggests that red-green colour blindness is:
- (i) sex-linked
  - (ii) recessive?
- (b) Give the number of *one* individual who is a carrier. Give reasons for your answer.
- (c) If individual 18 were to marry a female with red-green colour blindness, what would be the genotypes of:
- (i) their sons
  - (ii) their daughters

Explain your answers.

7. (a) Outline the main stages of meiosis I.
- (b) In maize:
- the allele for yellow seeds is dominant to that for colourless seeds
  - the allele for smooth seeds is dominant to that for wrinkled seeds

A plant heterozygous for both traits was crossed with a plant homozygous for both recessive alleles. The offspring were:

- coloured, smooth – 48%
- colourless, wrinkled – 48%
- coloured, wrinkled – 2%
- colourless, smooth – 2%

(i) How do these results support the idea that these genes are linked? Give reasons for your answer.

(ii) Draw a genetic diagram to show the results you would expect from a cross between two plants heterozygous for both traits. Assume no crossing over takes place.

8. The graph in figure 3.66 shows the change in the percentage of bacteria that cause pneumonia resistant to penicillin in the USA between 1986 and 2001.

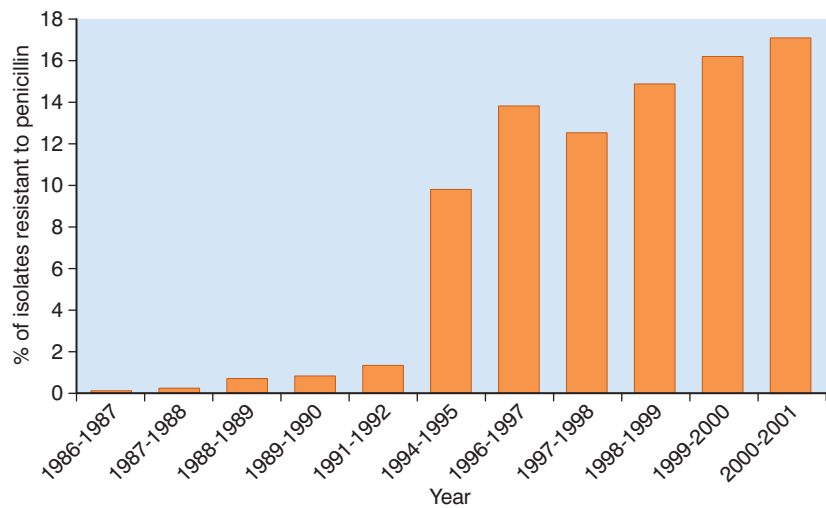


Figure 3.66

- (a) (i) Describe the trend shown in the graph.  
 (ii) Suggest an explanation for the trend you have described.

(b) Describe three ways in which bacteria can transfer antibiotic resistance from one bacterium to another.

9. Mary and Bob have three children. However, Bob suspects that the third child is not his, but is the child of another man called Larry. All the individuals have genetic fingerprints taken. Figure 3.67 shows these genetic fingerprints.

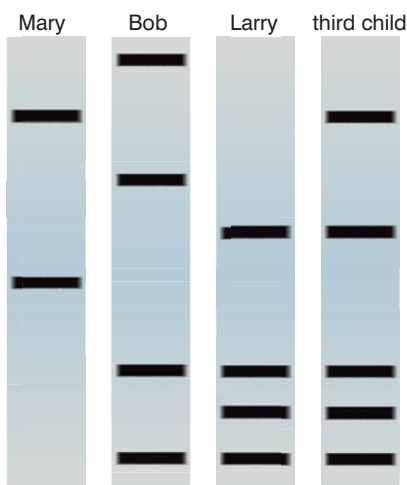


Figure 3.67

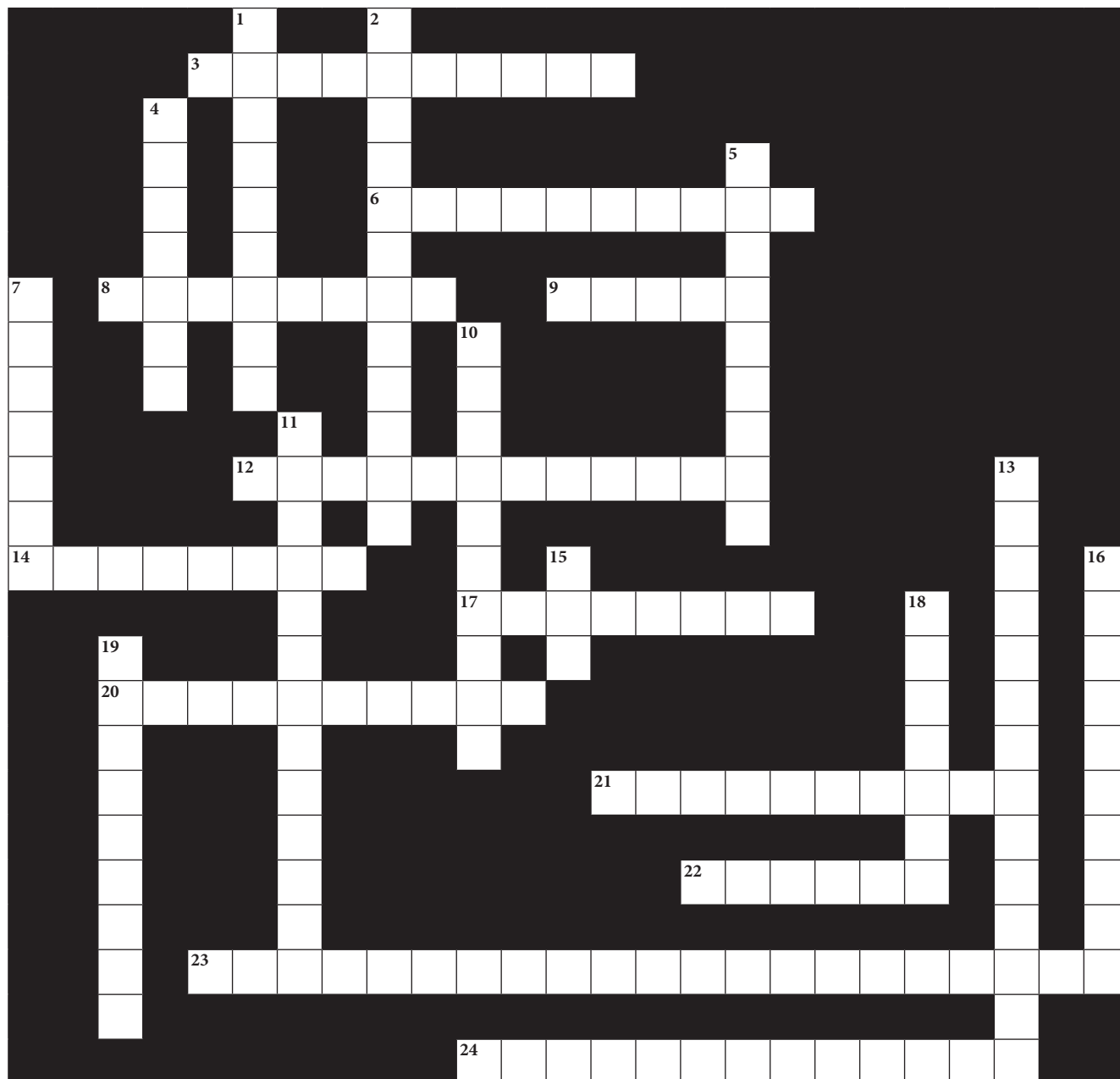
- (a) Describe how a genetic fingerprint is made.  
 (b) Was Bob justified in his suspicions? Explain your answer using information from the genetic fingerprints.



10. (a) Insulin is a peptide hormone containing 51 amino acids. It is produced in the islets of Langerhans in the pancreas.
- (i) How many bases would there be in the mRNA that controls insulin production? Explain your answer.
  - (ii) Outline how insulin is produced in cells in the islets of Langerhans.
- (b) People who suffer from type I diabetes must inject themselves regularly with insulin. Today, this insulin is made by genetically modified bacteria.
- (i) Describe the main steps in genetically modifying bacteria.
  - (ii) Gene technology has attracted much debate. Give two ethical concerns that some people have and suggest how these concerns might be eased.

Copy the crossword puzzle below into your exercise book (or your teacher may give you a photocopy) and solve the numbered clues to complete it.

### Classical genetics



#### Across

3. The structure that holds two chromatids together (10)
6. When a gene cannot be expressed in either male or female, it is said to be ... (3-7)
8. The allele that expresses itself in the heterozygote is ... (8)
9. A feature controlled by a gene is sometimes called a ... (5)
12. An organism carrying both dominant and recessive alleles for a feature is said to be ... (12)

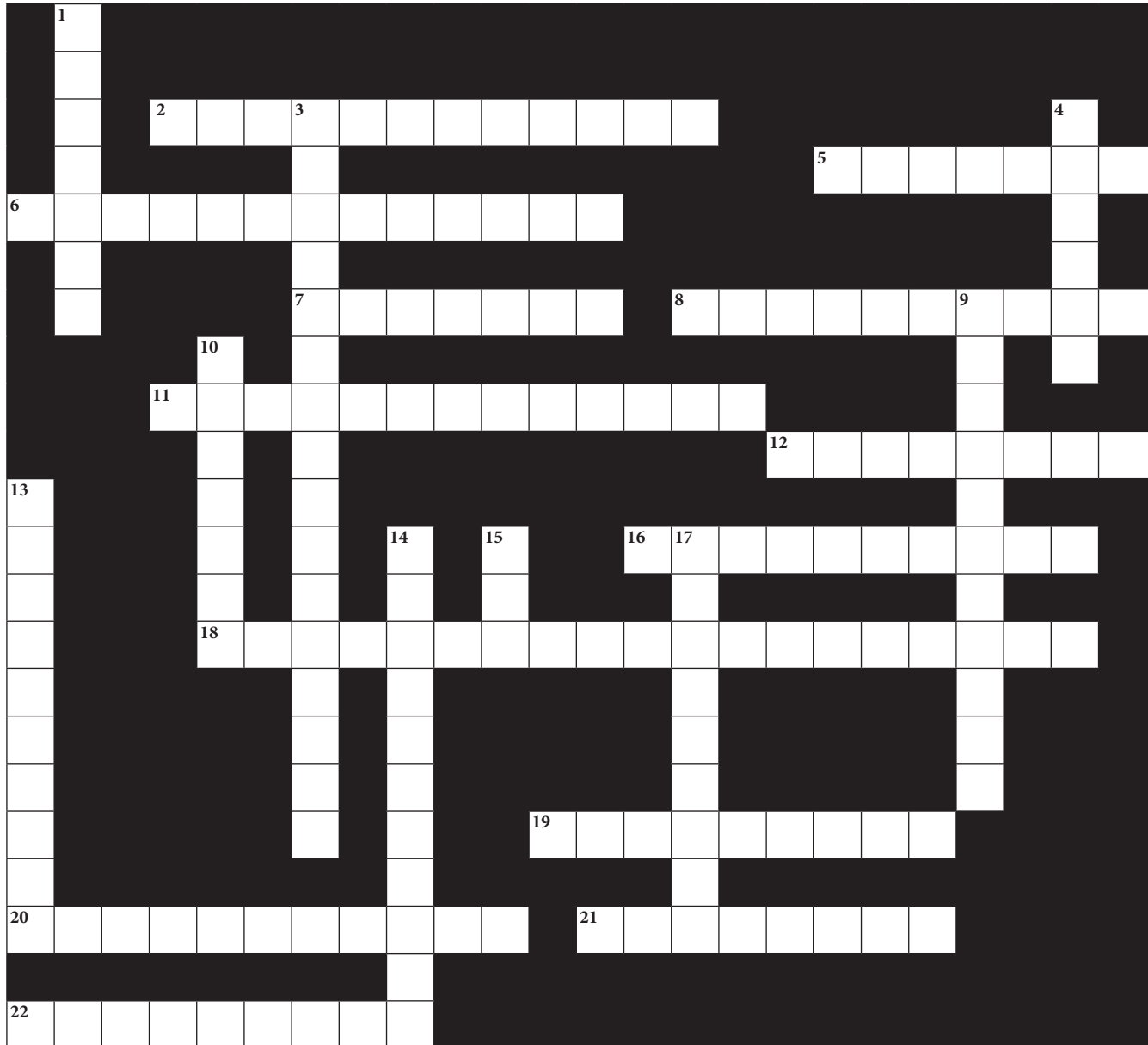
14. A genetic cross involving two features at the same time is a ... cross (8)
17. The alleles an organism possesses for a particular feature (8)
20. Chromosomes with the same genes at the same loci are said to be ... (10)
21. Genes that are carried on the X chromosome show... (3-7)
22. A version of a gene (6)
23. Mendel's law of ... states that one feature is inherited independently of another (11, 10)
24. A way of showing in a genetic cross how different gametes can combine (7, 6)

**Down**

1. The allele that is not expressed in the heterozygote is ... (9)
2. How genetic material is exchanged between homologous chromosomes in prophase I of meiosis (8, 4)
4. A cell with two sets of chromosomes is ... (7)
5. A procedure to find if an organism showing the dominant feature is homozygous or heterozygous (4, 5)
7. A cell with only one set of chromosomes is ... (7)
10. An organism carrying two dominant or two recessive alleles for a feature is said to be ... (10)
11. When the expression of a gene is affected by the gender of the person, it is said to be ... (3-10)
13. The type of inheritance shown by the ABO blood group alleles (8, 6)
15. Genes are made of this (3)
16. If both alleles express themselves in the heterozygote, they are said to be ... (10)
18. Alleles for two different features on the same chromosome show ... (7)
19. The physical expression of a genotype (9)

Copy the crossword puzzle below into your exercise book (or your teacher may give you a photocopy) and solve the numbered clues to complete it.

**Molecular genetics**



**Across**

- 2. A mutation in which one base is replaced by another (12)
- 5. A small, circular piece of DNA found in bacteria (7)
- 6. The sequence of bases on one strand of DNA is ... to the sequence on the other strand (13)
- 7. Taking cuttings is a traditional example of this process (7)
- 8. The enzyme which assembles nucleotides into a new DNA strand is DNA ... (10)
- 11. Rewriting the genetic code from DNA to mRNA (13)

12. A permanent genetic change (8)
16. The building block of a nucleic acid (10)
18. A protein that initiates transcription of a gene (13, 6)
19. The type of RNA that carries the genetic code from DNA to a ribosome (9)
20. Converting the code in mRNA into a sequence of amino acids (11)
21. The enzyme which 'unzips' a DNA molecule is DNA ... (8)
22. The type of DNA that does not code for any feature and is used in a genetic fingerprint (9)

**Down**

1. The protein associated with DNA in chromosomes (7)
3. The type of replication shown by DNA (4–12)
4. This enzyme helps two pieces of DNA to anneal (6)
9. This type of enzyme cuts a DNA molecule at a specific base sequence (11)
10. The three bases that code for an amino acid form a ... (7)
13. Addition and deletion are this type of mutation (10)
14. This rule states that, in DNA, A will always be opposite T and C opposite G (4, 7)
15. The polymerase chain reaction (acronym) (3)
17. Because the genetic code is the same in all organisms, it is said to be ... (9)

Contents	
Section	Learning competencies
4.1 The origin of life (page 171)	<ul style="list-style-type: none"> <li>• Explain what biologists generally understand by the term 'evolution'.</li> <li>• Describe and compare some of the different theories that seek to explain the origin of life on Earth, including special creation theory, spontaneous generation theory, eternity of life theory, cosmozoan theory and biochemical origin theory.</li> <li>• Describe some of the evidence supporting the biochemical origin theory, including the work of Oparin and Miller.</li> <li>• Appreciate the quest by humans for knowledge of their origins.</li> </ul>
4.2 Theories of evolution (page 183)	<ul style="list-style-type: none"> <li>• Appreciate that there have been several attempts to explain how evolution takes place.</li> <li>• Describe the theory proposed by Jean-Baptiste Lamarck.</li> <li>• Describe the theory proposed by Charles Darwin.</li> <li>• Compare these two theories.</li> <li>• Explain how our knowledge of genetics, behaviour and molecular biology has modified Darwin's ideas into a form called neo-Darwinism.</li> <li>• State the neo-Darwinian ideas of evolution.</li> </ul>
4.3 The evidence for evolution (page 191)	<ul style="list-style-type: none"> <li>• Explain how the following support the theory of evolution: palaeontology (the fossil record), comparative anatomy, comparative embryology, comparative biochemistry, plant and animal breeding experiments.</li> <li>• Describe examples of each of these types of evidence.</li> </ul>
4.4 The processes of evolution (page 204)	<ul style="list-style-type: none"> <li>• Define natural selection.</li> <li>• Explain the role in evolution of natural selection (including directional selection, stabilising selection and disruptive selection), isolation and speciation, adaptive radiation (divergent evolution) and convergent evolution.</li> <li>• List, describe and give examples of the different types of natural selection.</li> </ul>

## Contents

Section	Learning competencies
4.5 The evolution of humans (page 213)	<ul style="list-style-type: none"> <li>• Explain how humans have evolved.</li> <li>• Construct an evolutionary tree of human evolution.</li> <li>• Explain the importance of Lucy and Ardi in the study of human evolution.</li> <li>• Discuss some of the controversies surrounding human evolution.</li> </ul>

### 4.1 The origin of life

By the end of this section you should be able to:

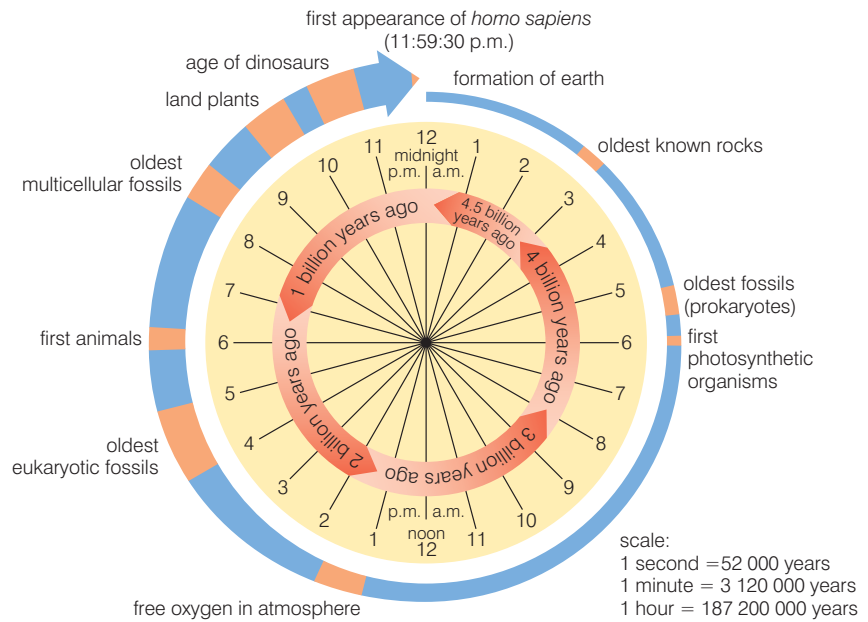
- Explain what biologists generally understand by the term 'evolution'.
- Describe and compare some of the different theories that seek to explain the origin of life on Earth, including special creation theory, spontaneous generation theory, eternity of life theory, cosmozoan theory and biochemical origin theory.
- Describe some of the evidence supporting the biochemical origin theory, including the work of Oparin and Miller.
- Appreciate the quest by humans for knowledge of their origins.

#### What is evolution?

When we talk of **evolution** we usually 'know what we mean' but, actually, it can be quite difficult to define. We usually think of the whole process – the whole 'course of evolution' starting with the origin of life and ending with the current biodiversity – with some notion that there must have been extinctions along the way. We think of new species arising and the biodiversity of the planet increasing and also, as evolution has progressed, there has been a general trend towards larger and more complex organisms. And we often put ourselves right at the pinnacle of evolution, as though things 'could not get any better than this'. We have something like the summary shown in figure 4.1 in mind.

#### KEY WORD

**evolution** *the theory of evolution describes how the various forms of life on Earth (including humans) emerged and developed*



**Figure 4.1** A summary of the course of evolution

But what is happening? How did all these millions of new species appear? We need a working definition of evolution which will take into account what is happening. Obviously, change is important when trying to explain evolution. Organisms have changed over time – they have evolved; we almost use the two words interchangeably. But why would an organism change? And would it matter if just one organism changed? For new species to appear, groups of organisms – populations – have to change, not just single organisms. For them to change, their genes must change, as the genes define what they will be by controlling protein synthesis (see unit 3).

So we can come up with a working definition of the process of evolution as:

*The change in genetic composition of a population over successive generations, which may be caused by meiosis, hybridisation, natural selection or mutation. This leads to a sequence of events by which the population diverges from other populations of the same species and may lead to the origin of a new species.*

### What theories are there about the origin of life on Earth?

There are five main theories of the origin of life on Earth:

- special **creationism**
- spontaneous generation
- eternity of life
- cosmozoan theory
- biochemical origin



## How does special creationism account for the origin of life?

Special creation is nearly always linked to religion, whereas an acceptance of evolution is linked to scientific thinking. There are fundamental differences between the two that mean it is unlikely that the difference between the scientific theory of evolution and special creation will ever be resolved. Science describes the natural world around us using a means of observation and empirical testing using instruments. These observations then result in the development of scientific theories. There is no attempt on the part of science to give opinions about morality or purpose.

Religion mainly focuses on spiritual matters that, by their very nature, cannot be seen, touched or measured effectively. Religion deals with philosophical matter that relates to morality and concerns between humans and their God. Religion is less concerned with empirical observable facts and testable hypotheses but rather with faith, the belief in things that cannot be proven.

Science relies on provable events; religion relies on believing in that which cannot be proven. The two views are very, very different from each other even though each is a valid worldview in its own context.

Special creation states that at some stage, some supreme being created life on Earth. There are many different versions of special creation, linked with different religions. Often, there is considerable variation as to how rigidly the special creation theory is interpreted within a religion.

### Young Earth creationism

This form of creationism today suggests that the Earth is only a few thousand years old. Young Earth creationists often believe the Earth was created in six 24-hour days. While they agree that the Earth is round and moves around the Sun, they interpret all geology in the light of Noah's flood.

### Old Earth creationism

There are several types of creationism that are considered Old Earth. They vary in different aspects of how they explain the age of the Earth while still holding to the story found in Genesis. Those who believe in Old Earth creationism accept the evidence that the Earth is very old but still maintain that all life was created by God.

### Day-age and gap creationism

These are similar in that each interprets the beginnings of the creation story as actually having taken much longer than six Earth days.

- Gap creation discusses a large gap between the formation of the Earth and the creation of all the animals and humans. The gap could be millions or billions of years. This gets around the scientific evidence that the Earth is several billion years old without having to believe in the process of evolution itself.

### KEY WORD

**creationism** (or *special creationism*) a theory claiming that the different forms of life on Earth were created by a supreme being

### Activity 4.1

Work in groups. Each group takes one theory of how life on Earth began and researches into it. Within your group discuss the theory and consider any scientific evidence which supports the theory. Plan a presentation to the rest of the class.

**KEY WORDS**

**intelligent design** *a theory claiming that life developed due to a combination of natural forces and the intervention of a supernatural being*

**spontaneous generation** *a theory that claimed that some types of organism could come into being almost instantly from non-living materials*

- Day-age creationism is similar in the length of time but talks about each of the six ‘days’ as really meaning a billion years or so of geologic time; the ‘days’ are just symbolic.

**Progressive creationism**

This type of creationism accepts the Big Bang as the origin of the Universe. It accepts the fossil record of a series of creations for all of the organisms catalogued. However, it does not accept these as part of a continuing process; each is seen as a unique creation. Modern species are not seen as being genetically related to ancient ones.

**Theistic evolution/Evolutionary creationism**

This view of evolution maintains that God ‘invented’ evolution and takes some form of an active part in the ongoing process of evolution. It also invokes the role of God in areas not discussed by science, like the creation of the human soul. Theistic evolution is promoted by the Pope for the Catholic Church and is also espoused by most mainline Protestants.

**Intelligent design**

This is the newest version of creationism and maintains that God’s handiwork can be seen in all of creation if one knows where to look. Advocates of **intelligent design** offer sophisticated arguments, often based on cell biology and mathematics, to give the impression of complex scientific arguments and to create equal stature with mainstream scientific thought. These arguments attack different parts of evolutionary theory, with the idea that if one part of evolutionary theory can be found to be incorrect then it follows that all of evolution must be incorrect. The term intelligent design is used to mask the fact that it’s a form of creationism cloaked in scientific-sounding ideas.

**How does spontaneous generation seek to explain life on Earth?**

**Spontaneous generation** suggests that life can evolve ‘spontaneously’ from non-living objects. It was only a few hundred years ago that people still believed this to be true. For example, people believed that rotting meat turned into flies and that wine produced bacteria as it went sour.

It took the work of Francisco Redi to disprove the idea of rotting meat producing flies and the work of Louis Pasteur to finally show that not even micro-organisms could be produced by spontaneous generation.

In Redi’s experiment, illustrated in figure 4.2, flies only appeared in the jars where flies had access in the first place. Exclude the flies, as he did with some jars, and the meat does not produce either maggots or flies.

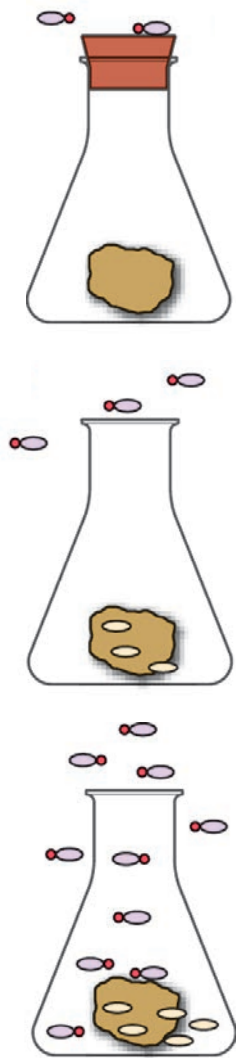
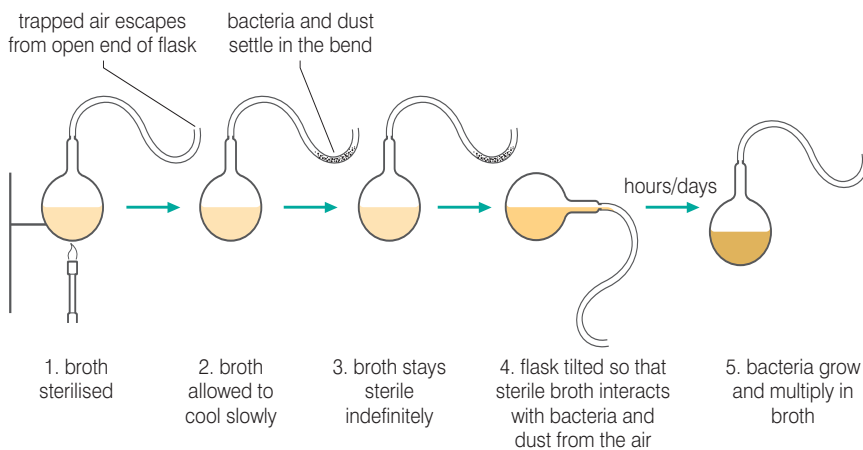


Figure 4.2 Redi’s experiment

Louis Pasteur showed that broth (or wine) only went sour if micro-organisms were allowed to enter. Also no micro-organisms appeared in the broth unless they were allowed to enter from the outside – they were not formed from the broth itself.



**Figure 4.3** Louis Pasteur finally disproves spontaneous generation

These two scientists showed that both macro-organisms (Redi) and micro-organisms (Pasteur) can only arise from pre-existing organisms, disproving the theory of spontaneous generation.

But what about the first ever cell? Unless we believe that life is eternal, with no beginning and no end, there had to be a first cell. And it could not have come from a pre-existing cell because it was the first.

As we shall see later, scientists have proposed a method whereby the necessary components of life could be formed and believe that, somehow, they managed to assemble themselves into a primitive cell. This is a kind of spontaneous generation.

### How does the eternity of life theory seek to explain life on Earth?

In this theory of life, there is no beginning and no end to life on Earth and so it neither needs special creation nor does it need to be generated from non-living matter. Supporters of this theory believe that life is an inherent property of the Universe and has always existed – as has the Universe. At the time when such theories were being propounded, many eminent scientists – including Albert Einstein – believed that the Universe was unchanging. They reasoned that ‘if life is found today in an unchanging Universe, then it must always have been there.’

### How does the cosmozoan theory seek to explain life on Earth?

According to this theory, life has reached this planet Earth from other cosmological structures, such as meteorites, in the form of highly resistant spores.

This idea was proposed by Richter in 1865 and supported by Arrhenius in 1908 and by other contemporary scientists. The

### Activity 4.2

Write a report describing briefly the theory of spontaneous generation. Explain carefully how we now know that spontaneous generation is not possible and does not happen.

### KEY WORDS

**eternity of life theory** claims that the Universe has always existed and that there has always been life in the Universe.

**cosmozoan theory** claims that life on Earth originally came from elsewhere in the Universe (possibly from another planet)



**Figure 4.4** Did meteorites bring life to Earth?

**DID YOU KNOW?****The steady state theory of the Universe**

Scientists now generally accept that the Universe began with a 'Big Bang' and will either expand for ever or will eventually contract again, ending in a 'Big Crunch'. However, for the early part of the twentieth century, a number of eminent astronomers and physicists believed that the Universe was in a 'steady state'. It had always existed the way it was and always would. The eternity of life theory is strongly linked to this theory of the Universe.

theory did not gain any significant support as it lacks evidence. It is strongly linked to the 'eternity of life' theory of the origin of life on Earth.

In the nineteenth century, Hermann Richter put forward the idea that life has always existed in the Universe, propagating itself from one place to another by means of 'cozmozoa' (germs of the cosmos). In this theory, life has existed and will exist for all eternity across the Universe, and so there is no need for an explanation of its origin. Two other eminent scientists of the time – Lord Kelvin and Herman von Helmholtz – also took the same view.

In 1908, the Swedish physical chemist Svante Arrhenius put forward a new version of the cosmozoan theory, and gave it the name panspermia. Arrhenius' contribution was a new theory of the mechanism by which life could be transported between planets; he proposed that bacterial spores were propelled through inter-planetary space by radiation pressure. Previous versions of the theory had assumed transport was by means of meteorites or by comets. However, the very high temperatures that meteorites create on entering the Earth's atmosphere seemed to rule this out. In Arrhenius' version of the theory, spores arriving at the Earth (possibly attached to grains of interstellar dust) could fall slowly to the ground without being subjected to high temperatures due to air friction.

One of the motivations for Arrhenius' panspermia theory was that it also seemed to provide a solution to the disproof by Louis Pasteur's experiments of spontaneous generation in bacteria. If there was no way in which the origin of life could be explained, it was reasonable to suppose that life was an inherent property of the Universe and had always existed. Arrhenius' theory was dropped by most scientists when it became apparent that the bacterial spores would be subject to UV radiation and X-radiation, zones of charged particles, which would inevitably destroy them.

However, another version of the cosmozoan theory or panspermia does have some evidence to back it up. This version – called weak panspermia or pseudo-panspermia – is the theory that organic compounds arrived from outer space and added to the chemicals on Earth that gave rise to the first life. In 1969 a meteorite landed in Australia that was 12% water and contained traces of 18 amino acids. This evidence points not only to the presence of organic compounds in outer space, but also to the capacity of such compounds to reach Earth. Also, complex organic molecules have been detected in star-forming clouds, further adding to the evidence for organic molecules in space.

**How does the biochemical theory seek to explain life on Earth?**

The current ideas we have about how life may have evolved on Earth as a result of biochemical reactions (sometimes called abiogenesis) owe much to two biologists working early in the twentieth century:

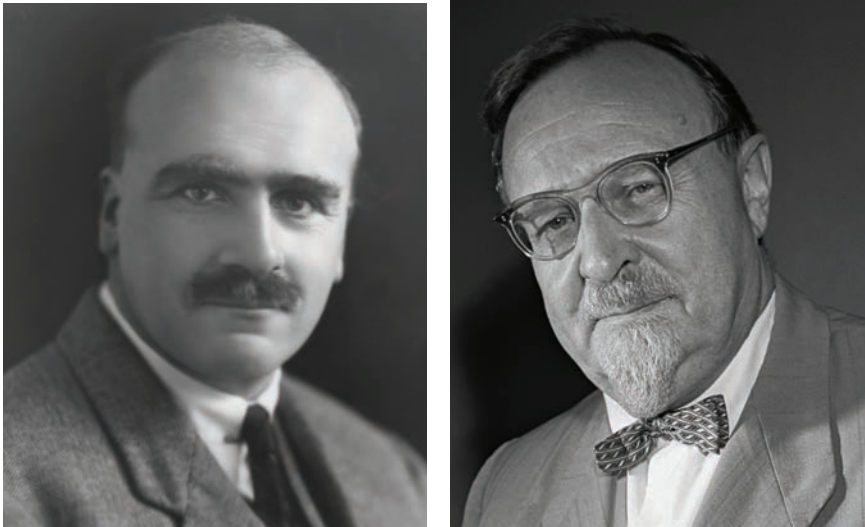


**Figure 4.5** Clouds of inter-stellar gas have been shown to contain organic molecules.

**KEY WORD**

**biochemical theory** suggests that life on Earth originated as a result of a number of biochemical reactions producing organic molecules which associated to form cells

- **Aleksandr Oparin**, a Russian biologist who first put forward his ideas in 1924, and
- **John Haldane**, an English biologist independently put forward almost identical ideas in 1929 (before Oparin's book had been translated into English).



*Figure 4.6 J B S Haldane and A I Oparin*

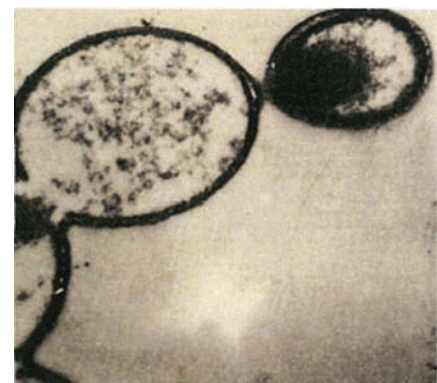
They both suggested that:

- the primitive atmosphere of the Earth was a reducing atmosphere with no free oxygen – as opposed to the oxygen-rich atmosphere of today
- there was an appropriate supply of energy, such as lightning or ultraviolet light, and
- this would provide the energy for reactions that would synthesise a wide range of organic compounds, such as amino acids, sugars and fatty acids.

Oparin suggested that the simple organic compounds could have undergone a series of reactions leading to more and more complex molecules. He proposed that the molecules might have formed colloidal aggregates, or 'coacervates', in an aqueous environment. The coacervates were able to absorb and assimilate organic compounds from the environment in a way similar to the metabolism of cells. These coacervates were the precursors of cells and would be subject to natural selection, eventually leading to the first true cells. Figure 4.7 shows some coacervate droplets containing amino acids and small polymers of one of the nitrogenous bases in DNA.

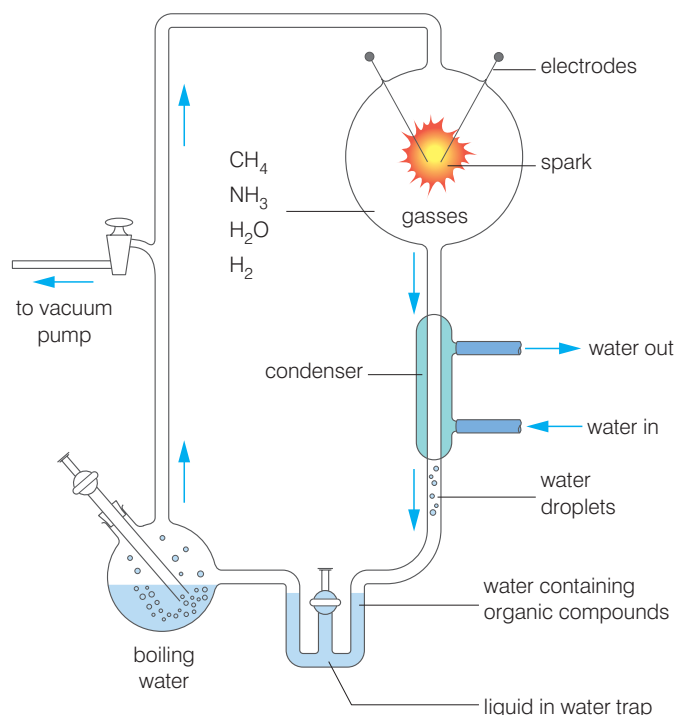
Haldane's ideas about the origin of life were very similar. He proposed that the primitive sea served as a vast chemical laboratory powered by solar energy. As a result of all the reactions powered by solar energy, the sea became a 'hot dilute soup' of organic monomers and small polymers. Haldane called this the 'prebiotic soup', and this term came to symbolise the Oparin-Haldane view of the origin of life.

But is there any evidence for the theory? In 1953, **Stanley Miller** conducted his now-famous spark-discharge experiment. In this



*Figure 4.7 Coacervate droplets – pre-cells?*

investigation, he passed electric sparks repeatedly through a mixture of gases that were thought to represent the primitive atmosphere of the Earth. These gases were methane ( $\text{CH}_4$ ), ammonia ( $\text{NH}_3$ ), water ( $\text{H}_2\text{O}$ ) and hydrogen ( $\text{H}_2$ ). The equipment he used is shown in figure 4.8.



**Figure 4.8** Stanley Miller's spark-discharge experiment

### KEY WORDS

**prokaryote** *an organism consisting of a prokaryotic cell. All bacteria are prokaryotes*

**eukaryote** *an organism consisting of one or more eukaryotic cells. All organisms other than bacteria are eukaryotes*

**archaebacterium** *the first bacteria (and thus the first living organisms) to develop on Earth. They are now only found in extreme conditions*

**eubacterium** *any bacteria that is not an archaebacterium is a eubacterium*

**photosynthesis** *the use of light energy to drive reactions that synthesise organic molecules; it occurs in plants, algae and some bacteria*

When he analysed the liquid in the water trap, he found it contained a number of simple organic molecules – hydrogen cyanide (HCN) was one of them.

He found that by leaving the equipment for longer periods of time, a larger variety and more complex organic molecules were formed including:

- amino acids – essential to form proteins
- pentose sugars – needed to form nucleic acids
- hexose sugars – needed for respiration and to form starch and cellulose
- hydrogen cyanide again – but it has been shown that the nitrogenous bases found in nucleotides can be synthesised in the laboratory using HCN as a starting point

There is then considerable evidence to support the Oparin–Haldane hypothesis. But it is not without its problems. These include:

- Why are only 'left-handed' amino acids found in living things when both left-handed and right-handed types are possible?
- Although nitrogenous bases can be synthesised in the laboratory, purines (adenine and guanine) are not synthesised under the same conditions as pyrimidines (thymine, uracil and cytosine); this is quite a serious problem for the theory.

- Although Miller was able to demonstrate the formation of monomers in his investigation, he was unable to demonstrate the next significant step of polymerisation of these monomers.

Recently, progress has been made in all of these areas. In 2009, John Sutherland, a chemist at the University of Manchester in England, found that, instead of making the nitrogenous base and sugar separately from chemicals likely to have existed on the primitive Earth, under the right conditions the base and sugar could be built up as a single unit (a nucleotide), and so did not need to be linked.

It has also been shown that polymerisation can occur under appropriate conditions and a solution is in sight for the 'handedness' problem.

The biologist John Desmond Bernal suggested that there were a number of clearly defined 'stages' in explaining the origin of life:

- Stage 1: the origin of biological monomers
- Stage 2: the origin of biological polymers
- Stage 3: the evolution from molecules to cell

Bernal suggested that evolution may have commenced at some time between stages 1 and 2.

The first two stages have been demonstrated as being possible in the conditions of the primitive Earth, and research on stage 3 is well advanced.

### Activity 4.3: Debating the origin of life

Your teacher will divide the class into groups with the following names:

- The Creationists
- The Spontaneous Generationists
- The Eternalists
- The Cosmozoans
- The Abiogenesisists

Each group must prepare a 'case' for their theory of the origin of life.

Once this is done, each group will, in turn, then start a debate by announcing: This house believes that only ... (Creationism, for example,) can truly account for the origin of life.

The group will have five minutes to put their case to the rest of the class.

The group starting the debate will then face five minutes of questions from a second group made up of one member from each of the other four groups.

At the end of this time, those members not involved directly in this debate will vote as to who they think has won the debate – the group proposing the theory or the group questioning the theory.

You must try to vote only on the debate, not on your personal views.

### DID YOU KNOW?

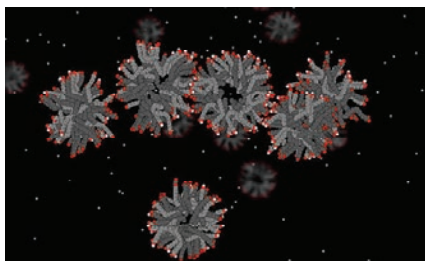
#### Other ideas on the biochemical theory

Professor William Martin Dusseldorf and Dr Michael Russell Glasgow claim that cells came before the complex organic molecules. Not living cells but inorganic ones made of iron sulphide, formed not at the Earth's surface but at the bottom of the oceans. In their theory, a fluid rich in compounds such as hydrogen, cyanide, sulphides and carbon monoxide emerged from the Earth's crust at the ocean floor. It then reacted inside the tiny metal sulphide cavities. They provided the right microenvironment for chemical reactions to take place. That kept the building blocks of life concentrated at the site where they were formed rather than diffusing away into the ocean. The iron sulphide cells are where life began.

**DID YOU KNOW?**

**Archaeobacteria are found in extreme conditions**

Thermophilic means 'heat-loving' and these bacteria are found at temperatures that would kill other cells. Very few cells can live in high concentrations of methane as can the methanobacteria or salt as can the halobacteria.



**Figure 4.9** Could pre-cells have looked like this when they were dividing?

**KEY WORDS**

**autotroph** *an organism that produces organic molecules from inorganic material*

**aerobic respiration** *a means by which cells release energy from organic molecules using oxygen*

**How did autotrophs evolve on Earth?**

However the first organisms appeared – about 4 billion years ago – they were **prokaryotes**. They had no true nucleus. It seems likely also that they had RNA rather than DNA as their genetic material. It seems likely that they gave rise to three distinct lines of evolution leading to:

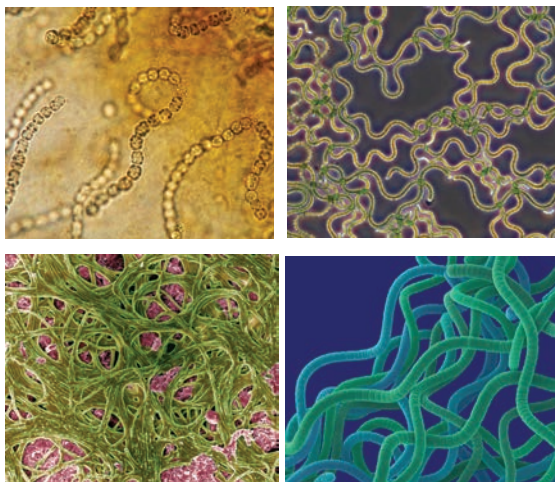
- **archaeobacteria** – prokaryotes including thermophilic sulphobacteria, methanobacteria and halophilic bacteria
- **eubacteria** – prokaryotes; ordinary bacteria and cyanobacteria (blue-green bacteria and sometimes known as blue-green algae)
- **eukaryotes** – eventually evolving into protocistsans, fungi, plants, animals (nearly all are aerobic)

One great change that affected the evolution of early life forms was the shift from the reducing atmosphere to an atmosphere containing oxygen. This took place about 2.4 billion years ago. Where did this oxygen come from?

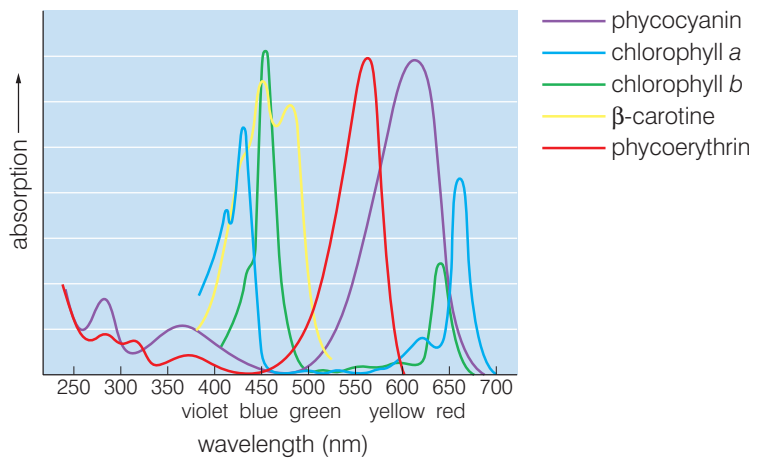
There is only one process we know of that can have produced it – **photosynthesis**.

The fossil record shows that cyanobacteria had been producing oxygen by photosynthesis from about 3.5 billion years ago but that for almost 1 billion years the levels in the atmosphere did not rise because the oxygen was absorbed by the vast amount of iron in the Earth – it rusted!! But, by 2.4 billion years ago, the concentration began to rise and the rate of increase accelerated from 2.1 billion years ago. Cyanobacteria are photo-autotrophs; they use light as a source of energy, and CO<sub>2</sub> as a source of carbon (photosynthesis). They are among the earliest of **autotrophs**, using, not chlorophyll, but another pigment, phycocyanin (which gives them their blue-green appearance), to capture light energy. You can see from figure 4.11 that phycocyanin absorbs different wavelengths of light from both chlorophyll a and chlorophyll b.

Other primitive autotrophs used not light as a source of energy but chemical reactions and are called chemo-autotrophs. Chemo-autotrophs use the energy from chemical reactions to synthesise all



**Figure 4.10** Cyanobacteria have been around for a long time



**Figure 4.11** Phycocyanin absorbs different wavelengths of light from chlorophyll



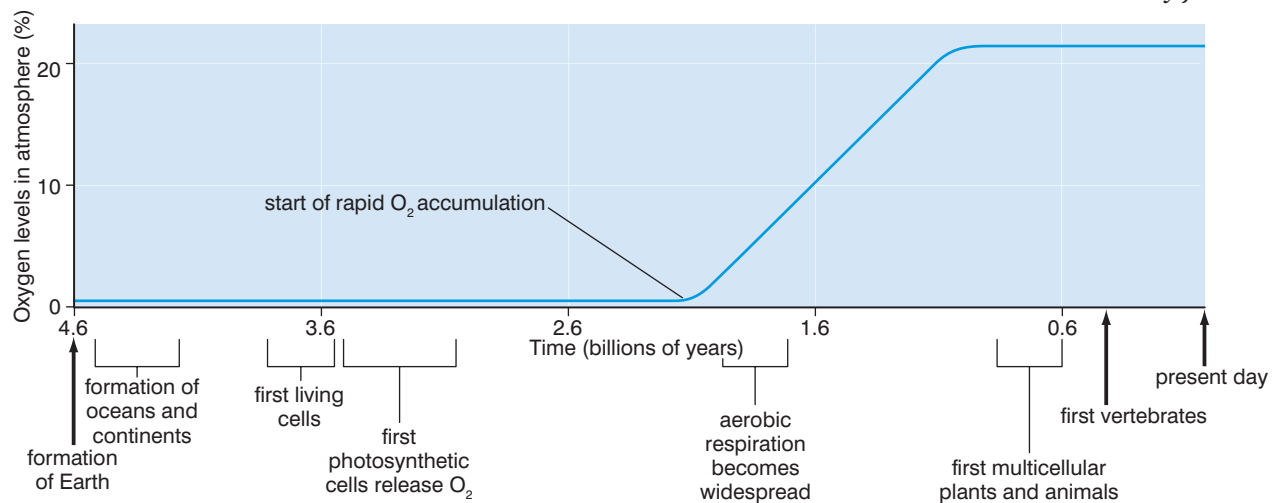
necessary organic compounds, starting from carbon dioxide. They generally only use inorganic energy sources. Most are bacteria or archaea that live in hostile environments such as deep sea vents and are the primary producers in ecosystems on the sea beds. Scientists believe that the some of first organisms to inhabit Earth were chemo-autotrophs.

The primitive sulphobacteria use hydrogen sulphide as the energy source. Hydrothermalism, particularly in deep sea vents, maintains the bacterial life of sulphobacteria and/or methanobacteria. Bacteria are the only life forms found in the rocks for a long time, 3.5 to 2.1 billion years ago. Eukaryotes became numerous 1.9 to 2.1 billion years ago and fungi-like organisms appeared about 0.9 billion years ago. The oxygen produced by the photo-autotrophs had made it possible for **aerobic respiration** to evolve as an energy-releasing pathway. As this process releases far more energy than does the anaerobic pathway more active organisms could now evolve – the animals, perhaps 600 to 700 million years ago.



**Figure 4.12** Was the first animal like this comb jelly?

**Figure 4.13** Life on Earth has evolved over billions of years



#### Activity 4.4: Class discussion 'The origin of life'

This topic can arouse quite strong emotions. People with a deep religious belief can be easily offended by those who deny the existence of any supreme being who created life and the universe. Equally, those who accept the biochemical origin of life often cannot understand how anyone could believe in a supreme being. During this activity, everyone will have the chance to put their point of view, but it is as much about listening as it is about making your own point. You must accept that other points of view are possible and listening carefully may make you revise your own position.

The activity will follow the following procedure:

- Your teacher will summarise the various theories on the origin of life.
- Your teacher will ask you for your opinions. You may then make your point of view but, during this stage, it is important that:
  - you do not interrupt anyone else; they also have the right to put their point of view
  - you only put your point of view when your teacher allows you to – the discussion cannot degenerate into a row!
- At the end of the discussion, your teacher will summarise the views of the class.
- You will write a summary of the main views held by different people in the group and why they hold those views. Do not comment on their views and reasons for holding them; just record them.

## Review questions

Choose the correct answer from A to D.

- Evolution is best described as:
  - a genetic change in an individual
  - a genetic change in an individual that is passed on through successive generations
  - a genetic change in a population
  - a genetic change in a population that is passed on through successive generations
- Special creationism always suggests that:
  - evolution is a tool of a supreme being
  - a supreme being created everything in its present state
  - a supreme being is somehow involved in the creation of life
  - none of the above
- In the past spontaneous generation has suggested that:
  - life can be created from non-living matter
  - micro-organisms can be created from non-living matter
  - flies can be created from rotting meat
  - all of the above
- The eternity of life theory suggests that:
  - all life forms are eternal
  - life has always existed and always will
  - life will go on forever
  - all of the above
- All forms of the cosmozoan (panspermia) theory suggest that:
  - life forms arrived on Earth from other celestial bodies
  - life forms arrived on Earth due to radiation pressure
  - organic molecules arrived on Earth in meteorites
  - other celestial bodies have been important in the origin of life on Earth
- All forms of the biochemical theory (abiogenesis) suggest that:
  - life evolved from non-biological molecules which reacted together and eventually formed pre-cells
  - life evolved from non-biological molecules which reacted together using solar or electrical energy at the surface of the oceans and eventually formed pre-cells
  - life evolved from non-biological molecules which reacted together using heat energy deep beneath the sea and eventually formed pre-cells
  - life evolved from non-biological molecules which reacted together in small pools and eventually formed pre-cells
- The first photo-autotrophic organisms were likely to have been:
  - green algae
  - sulphur bacteria
  - plants
  - blue-green bacteria
- From the time when oxygen was first produced on the planet, it took approximately how many years for the levels to begin to rise?
  - 1 000 000
  - 10 000 000
  - 100 000 000
  - 1 000 000 000
- Which of the following is the best definition of a chemo-autotroph?
  - An organism that uses chemical reactions as a source of energy.
  - An organism that uses chemical reactions as a source of energy to absorb its food.
  - An organism that uses chemical reactions as a source of energy to synthesise its own food.
  - An organism that uses chemical reactions as a source of energy to synthesise organic molecules, using carbon dioxide as a starting point.

10. The scientists who developed the theory of abiogenesis were:

- A Miller and Bernal
- B Miller and Oparin
- C Bernal and Haldane
- D Oparin and Haldane

## 4.2 Theories of evolution

By the end of this section you should be able to:

- Appreciate that there have been several attempts to explain how evolution takes place.
- Describe the theory proposed by Jean-Baptiste Lamarck.
- Describe the theory proposed by Charles Darwin.
- Compare these two theories.
- Explain how our knowledge of genetics, behaviour and molecular biology has modified Darwin's ideas into a form called neo-Darwinism.
- State the neo-Darwinian ideas of evolution.

### What theories of evolution are there?

In section 1 we arrived at a definition of evolution as:

*The change in genetic composition of a population over successive generations, which may be caused by meiosis, hybridisation, natural selection or mutation. This leads to a sequence of events by which the population diverges from other populations of the same species and may lead to the origin of a new species.*

But how does it happen? What drives the population to become a new species? Over time there have been many theories that have attempted to explain this. In this section we shall look at some of them.

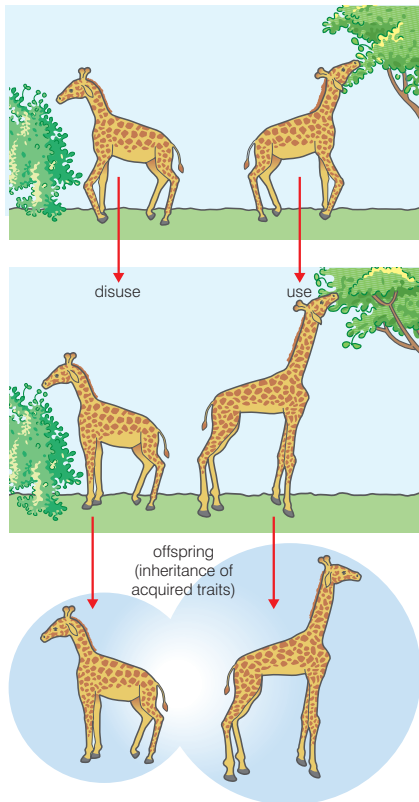
We owe much of our current thinking on natural selection to the ideas of Charles Darwin, who put forward the idea to the Royal Society in 1858. His paper suggested that those organisms that were best adapted to their environment would have an advantage and be able to reproduce in greater numbers than other types, and pass on the advantageous adaptations. Because he knew nothing of genetics, he was unable to suggest how this might take place.

For many years in Europe, the Christian belief had been that the Earth and all species had been created about 6000 years ago. In the mid 1700s, George Buffon challenged this idea, suggesting that:

- the Earth was much older than this, and that
- organisms changed over time in response to environmental pressures and random events.

**KEY WORD**

**Lamarckism** the theory developed by the French biologist Jean-Baptiste Lamarck that claimed that organisms passed on to subsequent generations traits acquired during their lifetime



**Figure 4.14** Lamarck's ideas of use and disuse and the inheritance of acquired traits of evolution

**DID YOU KNOW?**

**Epigenetics** is a relatively new branch of genetics. One of its important findings is that the way a gene expresses itself may become altered during an individual's lifetime. These changed genes may be passed on to the next generation. Is this the inheritance of acquired traits after all? Well, maybe, but certainly not in the way that Lamarck meant it.

Whilst we now accept these ideas almost without a second thought, at the time Buffon had no evidence to back them up and, as a result, could not convince people.

At the start of the nineteenth century, Lamarck, having read Buffon's ideas, made what is now considered to be the first major advance towards modern evolutionary thinking because he proposed a mechanism by which the gradual change in species might take place. In 1809 he published a paper entitled 'Philosophie Zoologique', in which he described a two-part mechanism by which change was gradually introduced into the species and passed down through generations. His theory is called the 'theory of transformation' or, more usually, simply '**Lamarckism**'. The two parts of his theory are:

- Use and disuse, and
- Inheritance of acquired traits.

**Use and disuse**

In this part of his theory, Lamarck suggests that by continually using a structure or process, that structure or process will become enlarged or more developed. Conversely, any structure or process that is not used or is little used will become reduced in size or less developed.

The classic example he used to explain the concept of use and disuse is the elongated neck of the giraffe. According to Lamarck, a given giraffe could, over a lifetime of straining to reach high branches, develop an elongated neck. However, Lamarck could not explain how this might happen. He talks about a 'natural tendency towards perfection' – but this is not really an explanation. Another example Lamarck used to illustrate his idea was the toes of water birds. He suggested that from years of straining their toes to swim through water, these birds gained elongated, webbed toes to improve their swimming.

These two examples demonstrate how use could change a trait. He used the wings of penguins as an example to illustrate what might happen to a structure with disuse. Their wings would have become smaller than those of other birds because penguins do not use them to fly.

**Inheritance of acquired traits**

Lamarck believed that traits changed or acquired during an individual's lifetime could be passed on to its offspring. Giraffes that had acquired long necks would have offspring with long necks rather than the short necks their parents were born with. This type of inheritance, sometimes called Lamarckian inheritance, has since been disproved by the discoveries of genetics.

However, Lamarck did believe that evolutionary change takes place gradually and constantly. He studied ancient seashells and noticed that the older they were, the simpler they appeared. From this, he concluded that species started out simple and consistently moved towards complexity, or, as he termed it, closer to perfection. These ideas we still retain today.

Just 50 years later, in 1858, Charles Darwin published his famous paper on Natural Selection. He had developed the idea some twenty years earlier, but was afraid of the ridicule the idea might receive. In 1858, another biologist, Alfred Russell Wallace, had come to similar conclusions and they jointly published the scientific paper to the Linnean Society of London that would change our thinking on the origin of species for ever.

Some of Darwin's evidence came from a visit to the Galapagos Islands. These are a small group of islands in the Pacific Ocean about 600 miles off the coast of Ecuador in South America.

Darwin visited five of the Galapagos Islands and made drawings and collected specimens. In particular, Darwin studied the finches found on the different islands and noted that there were many similarities between them, as well as the obvious differences. He concluded that the simplest explanation was that an 'ancestral finch' had colonised the islands from the mainland and, in the absence of predators, been able to adapt to the different conditions on the islands and, eventually, evolve into different species. Some of the finches had, he suggested, evolved into insect eaters, with pointed beaks. Others had evolved into seed eaters with beaks capable of crushing the seeds. One hundred and fifty years later on and geneticists have been able to confirm Darwin's ideas and even produced a 'family tree' based on the similarity of their DNA. Figure 4.16 shows this family tree.



Figure 4.15 Charles Darwin as a young man

**The Galapagos finch family tree**

The horizontal lines indicate the amount of genetic difference researchers found in the finch DNA. Short horizontal lines mean few differences and imply close relatedness. For example, all the tree finches are joined by short horizontal lines, indicating they are all closely related to each other.

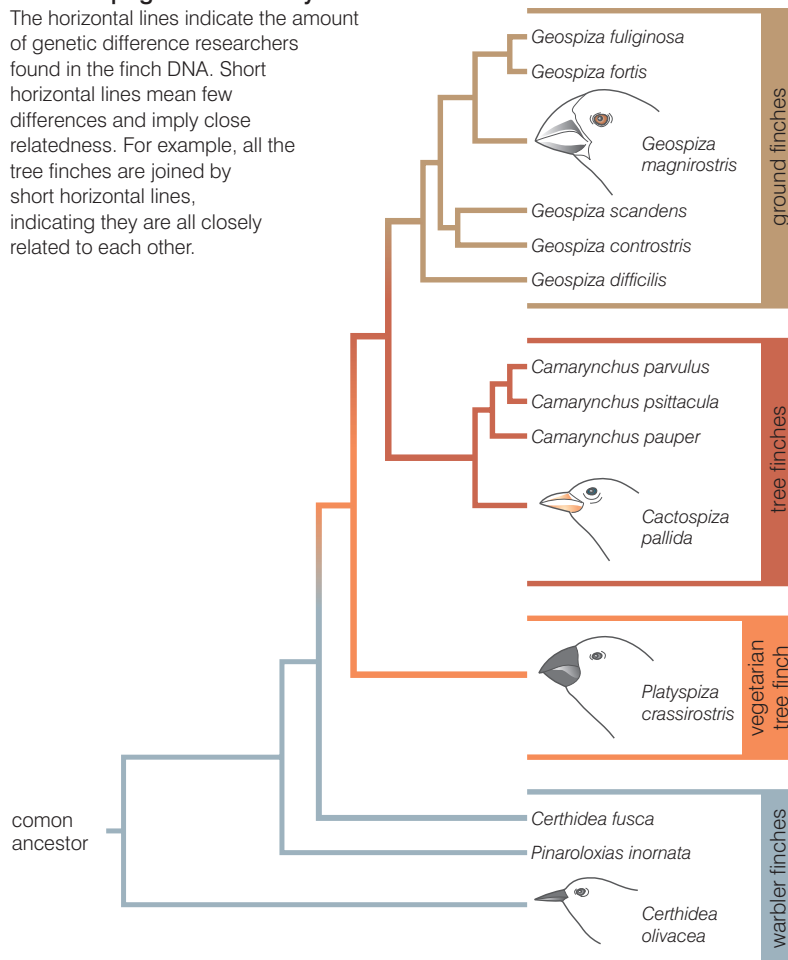
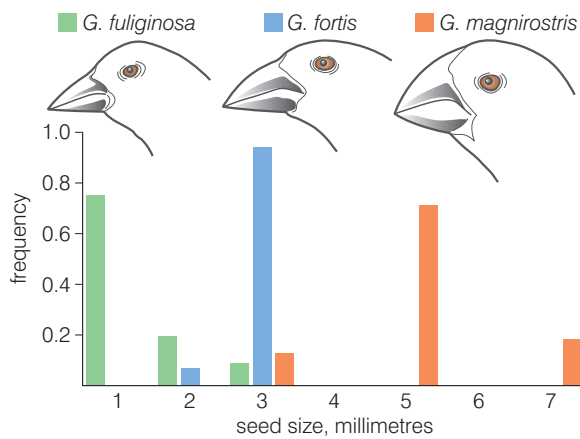


Figure 4.16 Genetic similarities in 'Darwin's finches'



**Figure 4.17** The different sizes of seeds eaten by three species of ground finch from the Galapagos Islands

Biologists wanted to test how well the finches were adapted to their ‘niche’. They analysed the sizes of the seeds eaten by three different ground finches. Figure 4.17 shows what proportion of each species ate the different sized seeds.

As you can see, although there is a little overlap, each finch eats seeds of a different size and their beaks are adapted to obtain and crush these different-sized seeds.

At the time, Darwin called this ‘descent with modification’ and believed it to be key evidence in support of his theory of natural selection. We now call this ‘adaptive radiation’.

Darwin summarised his observations in two main ideas:

- all species tend to produce more offspring than can possibly survive
- there is variation among the offspring

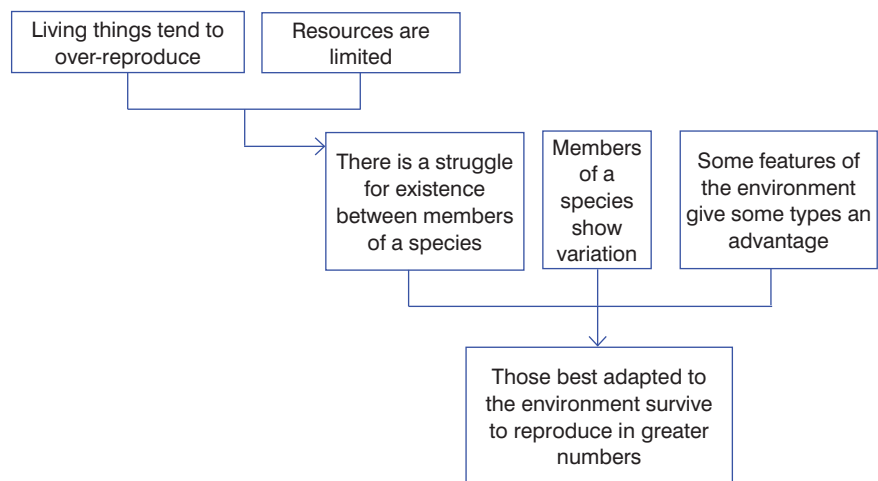
From these observations he deduced that:

- There will be a ‘struggle for existence’ between members of a species (because they over-reproduce, and resources are limited).
- Some members of a species will be better adapted than others to their environment (because there is variation in the offspring).

Combining these two deductions, Darwin proposed:

*Those members of a species which are best adapted to their environment will survive and reproduce in greater numbers than others less well adapted.*

This is his now-famous theory of natural selection, and can be summarised in the flow chart below.



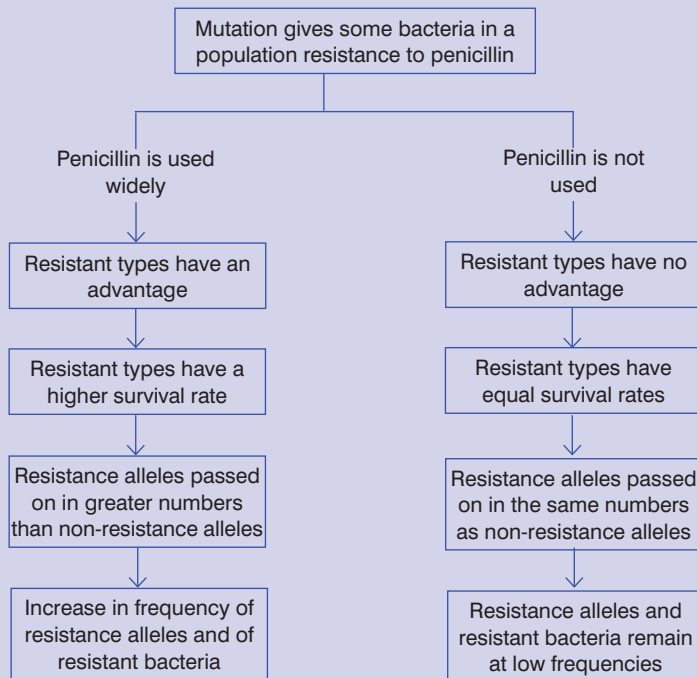
**Table 4.1** Comparison of Lamarck’s theory of use and disuse with Darwin’s theory of natural selection

Aspect of theory	Lamarck’s theory of use and disuse	Darwin’s theory of natural selection
Variation	Environment changes, creating a need for the organism to change	There is a natural variation in features and the variations are heritable
Survival	Development of new features (e.g. longer neck) in order to survive	Environment selects in favour of those traits that adapt the organism to the environment and against those that do not
Inheritance	New features acquired during lifetime of an individual are passed to the offspring	Individuals with advantageous variations of traits survive in greater numbers and pass on these advantageous variations to their offspring
Evolution	New species over time	New species over time

**DID YOU KNOW?**

**About antibiotic resistance – a modern example of selection in action**

Mutations in bacteria can make them resistant to an antibiotic, for example, penicillin. If they are resistant to penicillin, it will have no effect on their growth and reproduction. What happens next depends on whether the bacterial population is exposed to the antibiotic, or not. This is summarised in the flow chart.



**KEY WORD**

**neo-Darwinism** *a revised version of Darwin's theory of evolution by means of natural selection. This theory, which is now accepted by most biologists, combines Darwin's original theory, genetic theory and theories about animal behaviour*

**Activity 4.5**

Some people have suggested that breeding animals and plants for use on farms is very similar to natural selection. Working in small groups, discuss this idea and make lists of the ways in which breeding farm animals and plants is similar to and different from natural selection.

**What is neo-Darwinism?**

Charles Darwin knew very little of genetics. Mendel had not carried out his ground-breaking work on inheritance at the time Darwin published his book *On the Origin of Species*. However, we can now incorporate our knowledge of genes and gene action into the theory of natural selection to give a better understanding of what drives evolution.

Genes or, more accurately, alleles of genes determine features. But when we think about how a population might evolve into a new species, we need to think not just in terms of the alleles each individual might carry, but also in terms of all the alleles (of all the genes) present in the population. We call this the gene pool of the population.

Suppose an allele determines a feature that gives an organism an advantage in its environment. The following will happen:

- Those individuals with the advantageous allele of the gene will survive to reproduce in greater numbers than other types.
- They will pass on their advantageous allele in greater numbers than the other types pass on their alleles of the same gene.
- The frequency of the advantageous allele in the gene pool of the population will be higher in the next generation.
- This process repeats over many generations and the frequency of the advantageous allele in the gene pool increases with each generation that passes.

Mutations are important in introducing variation into populations. Any mutation could produce an allele which:

- confers a selective advantage; the frequency of the allele will increase over time
- is neutral in its overall effect; the frequency may increase slowly, remain stable or decrease (the change in frequency will depend on what other genes/alleles are associated with the mutant allele)
- is disadvantageous; the frequency of the allele will be low and could disappear from the population.

But **neo-Darwinism** doesn't just take into account our knowledge of genetics. It also encompasses our understanding of animal behaviour – sometimes referred to as ethology. Many ethologists and also evolutionary psychologists believe that it is not just physical features that can confer an advantage, but that behaviour patterns can also be advantageous – or not. As such, a behaviour pattern that confers a survival advantage will be selected for, whilst those that do not will be selected against. An example of an advantageous behaviour is imprinting in geese. Young geese (goslings) 'imprint' upon the first moving object that they see after hatching, and follow it everywhere. Since this will almost certainly be 'mother goose' there is a very obvious survival advantage in following her; the young goslings will be fed and protected. Any goslings that do not show this behaviour pattern are much less likely to survive.



## Review questions

Choose the correct answer from A to D.

1. A gene pool is:
  - A all the genes in an individual
  - B all the alleles in an individual
  - C all the alleles in a population
  - D all the genes in a population
2. As a result of natural selection, those most adapted to an environment survive to reproduce in the greatest numbers because:
  - A resources are limited
  - B resources are limited and there is a natural variation between members of a population
  - C resources are limited, there is a natural variation between members of a population and living things tend to over-reproduce
  - D none of the above
3. New alleles arising from mutations in a population will:
  - A increase in frequency if they are beneficial in their effect and decrease in frequency if they are neutral in their effect
  - B increase in frequency if they are neutral in their effect and decrease in frequency if they are harmful in their effect
  - C increase in frequency if they are beneficial in their effect and increase in frequency if they are neutral in their effect
  - D increase in frequency if they are beneficial in their effect and decrease in frequency if they are harmful in their effect
4. Bacterial populations can develop a resistance to antibiotics. Which of the factors listed below does NOT contribute to the development of antibiotic resistance?
  - A random mutations in the bacterial population
  - B the repeated use of the same antibiotic on a bacterial population
  - C careful selection of the most effective antibiotic to use on a bacterial population
  - D people not completing a course of antibiotics so that some bacteria survive
5. In comparing Darwin's theory of evolution with Lamarck's, it is true to say that:
  - A Darwin based his theory on natural selection whilst Lamarck based his on use and disuse

- B Lamarck believed that variation arose out of a need to change whereas Darwin suggested that variations were already present in populations
  - C both suggested that new species could evolve eventually
  - D all of the above
6. Darwin's finches were able to evolve into 14 different species from one ancestral type because:
- A there were many different habitats and niches on the Galapagos islands
  - B there was variation in the population of ancestral finches that colonised the islands
  - C there was little competition for the niches
  - D all of the above
7. Neo-Darwinism is a modification of Darwin's original theory that takes into account:
- A the inheritance of acquired characteristics and ethology
  - B behavioural psychology and molecular genetics
  - C genetics and ecology
  - D genetics and ethology
8. Although now discredited, Lamarck's work is regarded as important because he attempted to explain:
- A how new species could appear over a long period of time
  - B how an individual could acquire new characteristics
  - C how a gene pool could change over time
  - D how mutations could appear
9. Darwin's theory of natural selection was based on the observations that:
- A all things tend to over-reproduce and there is a struggle for existence
  - B there is variation in populations and there is a struggle for existence
  - C some members of a population are better adapted than others and there is a struggle for existence
  - D all things tend to over-reproduce and there is variation in populations
10. Which of the following statements does not describe why imprinting by goslings is adaptive behaviour (has survival value)?
- A it helps makes sure the goslings will be protected
  - B it helps make sure the goslings will be fed
  - C it helps them solve abstract problems
  - D it helps make sure the goslings stay together and so are less likely to be predated

### 4.3 The evidence for evolution

By the end of this section you should be able to:

- Explain how the following support the theory of evolution: palaeontology (the fossil record), comparative anatomy, comparative embryology, comparative biochemistry, plant and animal breeding experiments.
- Describe examples of each of these types of evidences.

#### How does palaeontology support the theory of evolution?

The word 'palaeontology' refers to the study of ancient life and comes from the Greek words *palaios* (ancient) and *logos* (study). Fossils form the basis of this science as they are the main direct evidence about past life.

Fossils (this word is derived from the Latin word *fossus*, meaning 'having been dug up') are the remains or traces of animals, plants and other organisms from the remote past. We can group fossils into two categories:

Category 1: the remains of the dead animal or plant or the imprint left from the remains, including:

- bones
- teeth
- skin impressions
- hair
- the hardened shell of an ancient invertebrate such as a trilobite or an ammonite
- an impression of an animal or plant, even if the actual parts are missing

Category 2: something that was made by the animal while it was living that has since hardened into stone; these are called trace fossils and include:

- footprints
- burrows
- coprolite (animal faeces)

Type I fossils can be the actual organism or part of an organism, like a piece of bone or hair or feather as it actually was. For example, this spider has been trapped, completely unchanged, inside the amber for millions of years. Amber is fossilised resin from trees. This spider probably became stuck inside the sticky resin and could not escape. As the amber became fossilised, the spider was protected from micro-organisms and air which would have led to its decomposition. In many fossils like this, the soft parts of the body



**Figure 4.18** A spider preserved in amber

have been lost, but the exoskeleton is perfectly preserved. In some cases, however, the entire body remains.

However, when we think of fossils, we usually think of imprints of whole organisms or parts of organisms – the last two examples of category 1 fossils. So how do these fossils form? Clearly death of the organism, for some reason or other, is the first stage. But death is nearly always associated with decomposition – which obviously doesn't happen when fossils are formed. So how is this prevented and just how do fossils form? There are four main stages:

### 1. Death without decomposition

To start with, an animal or plant must die in or so close to water that it is covered by water immediately after, or shortly after, death. The water insulates the remains from many of the elements that contribute to decomposition. Bacteria will still decay the soft body parts over a long period but leave any hard body parts unaltered.

### 2. Sedimentation

As time passes, sediments (tiny particles of solid matter settling out of the water) bury the remaining hard parts of the organism. Fossilisation is more likely if this happens quickly than if it happens slowly. Sudden landslides and mudslides into the water help. Sedimentation further insulates the organism from complete decay.

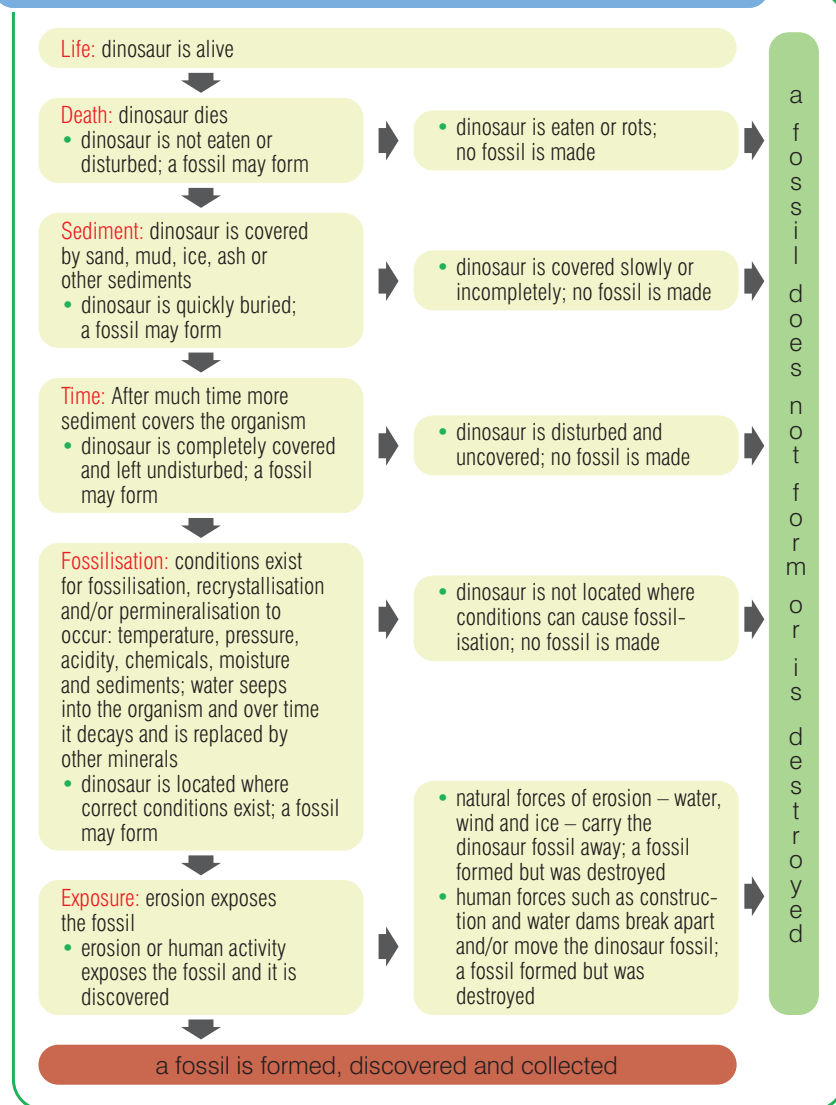
The nature of the sediments themselves influences the nature and quality of the fossil. Very fine-grained particles, like clays, will create a more detailed fossil than coarser-grained sediments like sand. The chemical make-up of the sediments affects the colour the fossil will be. Iron-rich sediments could give the rock (and the fossil) a reddish colour. Phosphates may darken the rock so that it is grey or black.

### 3. Permineralisation

As the sediments accumulate, the lower layers become compacted by the weight of the layers on top. Over time, this pressure turns the sediments into rock. If water rich in minerals percolates (seeps) through the sediments, the mineral particles stick to the particles of sediment, effectively gluing them together into a solid mass. An important point here is that these minerals are probably not the same minerals that make up the sediments (now rock).

Over the course of millions of years, these mineral particles dissolve away the original hard parts of the organism, replacing the molecules of exoskeleton with molecules of calcite (calcium carbonate) or another mineral. In time, the entire shell is replaced by mineral particles and these also are compressed into rock in the shape of the original organism. As this rock is not the same as the surrounding rock, it is visible as a fossil in the exact shape of the original organism. Figure 4.19 shows how a dinosaur fossil may form.

**How a dinosaur fossil forms – step by step**



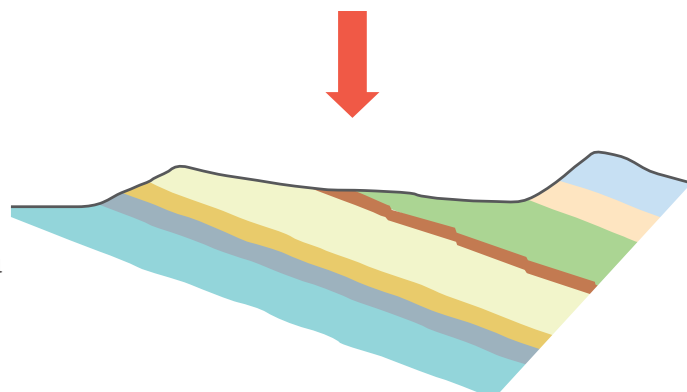
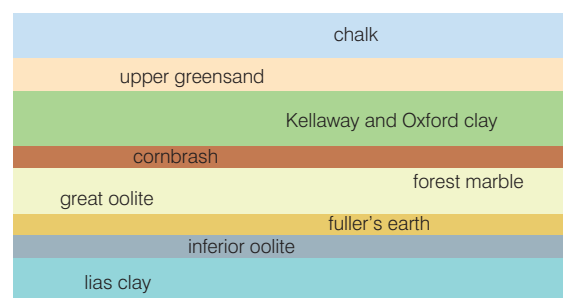
*Figure 4.19 How a dinosaur fossil may form*

*Figure 4.20 Earth movements may expose rocks that were deep beneath the surface.*

**4. Uplift**

As the continental plates move around the Earth, colliding with each other, mountains are formed. What were sea floors are lifted up and become dry land. Now the fossil is buried under hundreds or even thousands of feet of rock in different strata. A stratum is a layer of sediment (or sedimentary rock) that is the same throughout the layer, but different from layers above and below.

Other Earth movements cause rocks to slip and parts of different strata to become exposed. When this happens, rock that contains fossils becomes lifted to the Earth's surface. Rain, wind, earthquakes, freeze and thaw erode rock and may expose a fossil. You just need to know where to look!



**KEY WORD**

**half-life** *the time needed for half the atoms of a radioactive substance to decay. After two half-lives, three quarters of the atoms will have decayed, and so on*

**How can we date fossils?**

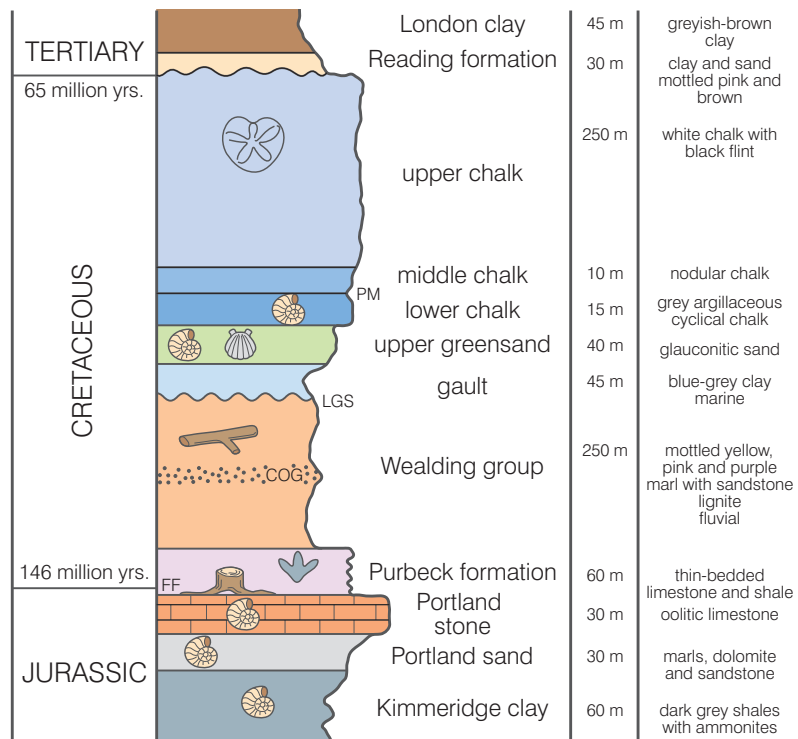
Because sedimentary rocks are laid down in layers (strata) we can use the sequence of the strata and the fossils that occur in them to deduce how the organisms have changed over time. This is called stratigraphy. The oldest strata, and therefore the oldest fossils, will be in the lowest layers and more recent rocks and fossils in layers above them, with the most recent being nearest to the surface.

Figure 4.21 represents the sequence of the strata at a site in southern England. The depth of the strata is related to their age. The thickness of each stratum (shown in the diagram) is a measure of the time period during which that stratum was formed. The names ‘Tertiary’, ‘Cretaceous’ and ‘Jurassic’ are the names of some of the geological periods of time. But how do we actually date the rocks? How do we find out how old each layer is?

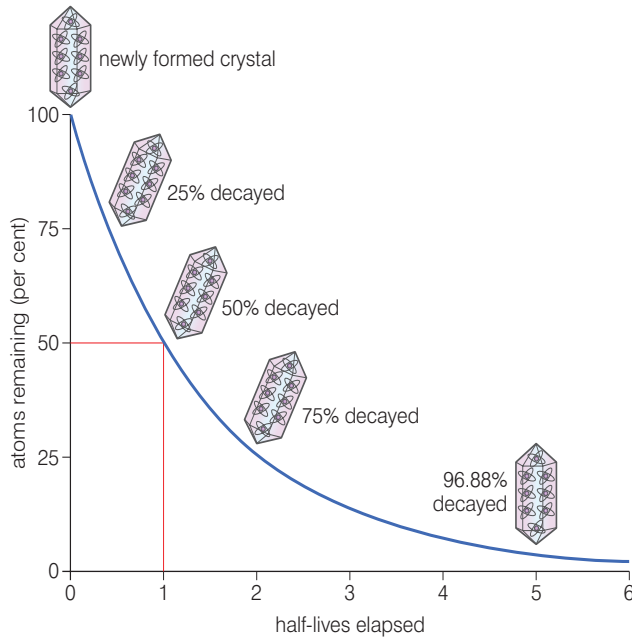
To do this, we biologists use one of two techniques:

- radiocarbon dating, or
- potassium–argon dating.

Both these techniques rely on the principle that radioactive atoms decay into other atoms over time. Radioactive carbon atoms ( $C^{14}$ ) decay into non-radioactive nitrogen atoms (N). Radioactive potassium atoms ( $K^{40}$ ) decay into argon atoms ( $A^{40}$ ). Each has what is known as a **half-life**. During this period, half of the radioactive atoms decay. So, starting with a certain number of radioactive potassium atoms, after one half-life, 50% will still be radioactive. After a second half-life, 50% of this 50% will have decayed and 25% of the original number will still be radioactive.



**Figure 4.21** Stratigraphy allows us to deduce the relative age of fossils.



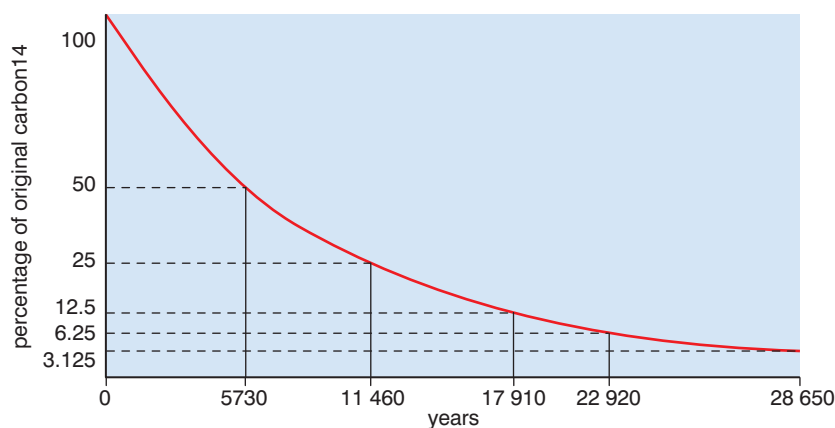
**Activity 4.6**

Carry out research into the 22 million year old fossils found in Ethiopia in 2010 and explain why these fossils are thought to be so important.

**Figure 4.22** Half-life of a radioactive element

The ratio of carbon 14 (radioactive carbon) to carbon 12 (ordinary carbon) in living things is about 1 to 1 trillion and we believe that this ratio has always been the same. During their lives, living things lose carbon 14 (as carbon dioxide and other excretory products) and also gain it in the food they eat (or make in the case of autotrophs).

But when living things die, the carbon 14 starts to decay into non-radioactive nitrogen and, clearly, is not replaced. So after 5730 years (one half-life of carbon 14), only 50% of the original carbon 14 atoms will remain and the ratio of carbon 14 to carbon 12 will be 1 to 2 trillion (or 0.5 to 1 trillion). After 11 460 years, 25% of the original carbon 14 atoms remain and the ratio is 1 to 4 trillion (or 0.25 to 1 trillion). The percentage of carbon 14 atoms and the ratio of carbon 14 to carbon 12 keeps halving with each half-life that passes. This is shown in figure 4.23.

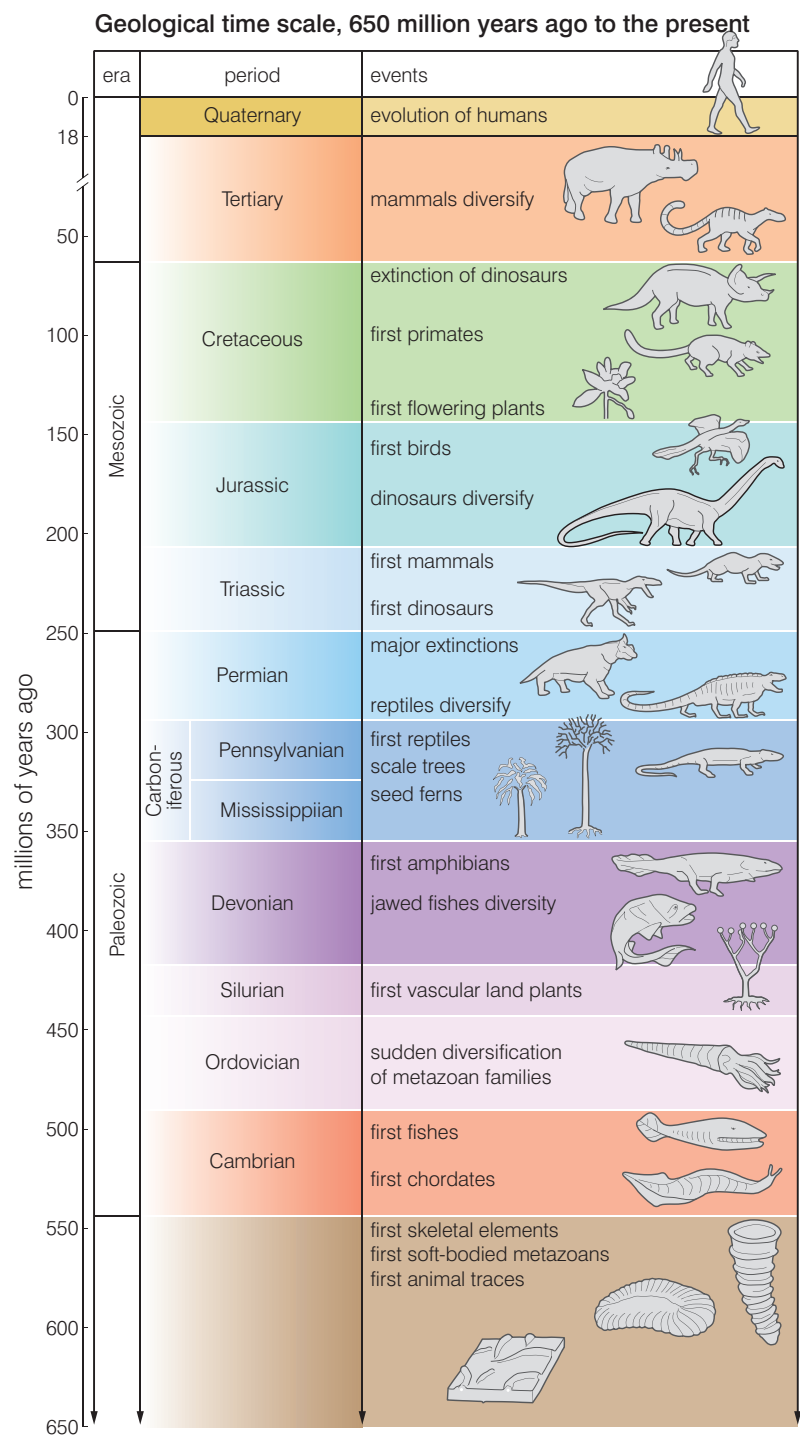


**Figure 4.23** Converting the percentage of carbon 14 in a fossil to an age

So, if we analysed a fossil and found that it had only 6.25% of its original carbon 14 atoms, we would know that it was 22 920 years old.

Potassium–argon dating works in the same way, but the half-life in this case is 1.3 million years. This makes potassium–argon dating suitable for dating rocks millions of years old, whereas radiocarbon dating is really only accurate with rocks up to 60 000 years old.

Putting together information from stratigraphy and radiometric dating, the fossil record for animals gives the picture shown in figure 4.24.



**Figure 4.24** Key events in the fossil record of animal evolution



### Activity 4.7: Dating fossils

Use the graph in figure 4.23 to work out the following:

- the age of a fossil containing 25% of the original carbon 14 atoms
- the age of a fossil containing 3.125% of the original carbon 14 atoms
- the approximate age of a fossil containing 20% of the original carbon 14 atoms
- why radiocarbon dating becomes less accurate with older fossils

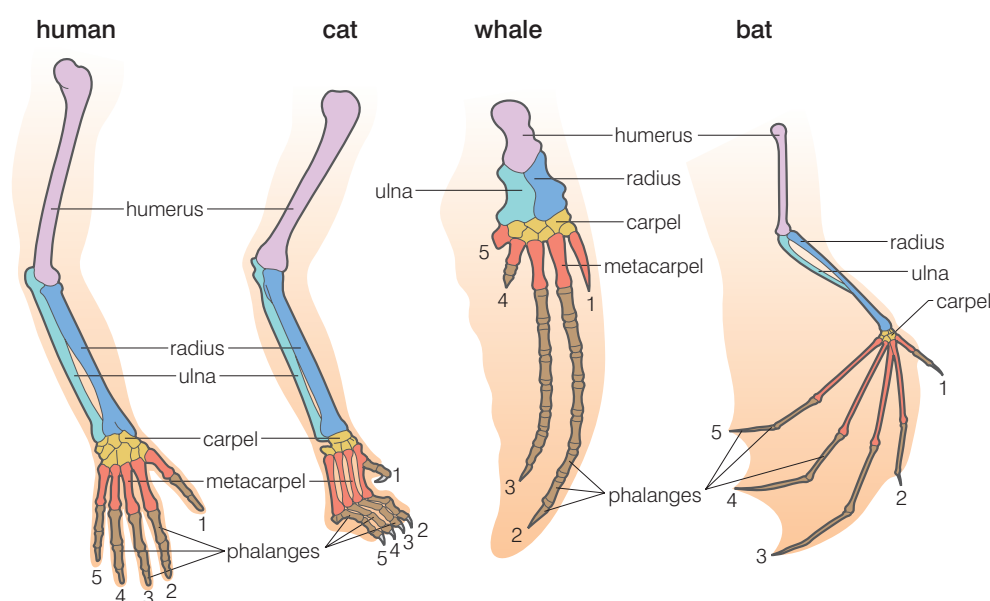
### How does comparative anatomy support the theory of evolution?

This is one of the strongest forms of evidence for evolution. Comparative anatomy looks at structural similarities of organisms and uses these to determine their possible evolutionary relationships. It assumes that organisms with similar anatomical features are closely related evolutionarily, and that they probably share a common ancestor.

Some organisms have anatomical structures that are very similar in form, but very different in function. We call such structures **homologous structures**. Because they are so similar, they indicate an evolutionary relationship and a common ancestor of the species that possess them. Perhaps the best-known example of homologous structures is the forelimb of mammals. When examined closely, the forelimbs of humans, whales, cats and bats are all very similar in structure, as figure 4.25 shows.

### KEY WORD

**homologous structures**  
structures with the same basic anatomy and a common evolutionary origin but having a different function



**Figure 4.25** The forelimbs of mammals are homologous structures

**DID YOU KNOW?**

Pentadactyl means ‘five-fingered’. The basic ‘plan’ of a pentadactyl limb is (starting from the ‘body’ and working outwards):

- a single long bone (the humerus)
- a pair of long bones (the radius and ulna)
- a cluster of small bones (the carpals – in the wrist)
- five sets of meta-carpals and digits (the fingers)

**KEY WORDS**

**pentadactyl limb** *a limb with five digits*

**analogous structures** *structures having the same function but different anatomy and different evolutionary origin*

Each possesses the same number of bones, arranged in almost the same way, while they have different external features and they function in different ways:

- arm for manipulation in humans
- leg for running in cats
- flipper for swimming in whales
- wing for flying in bats

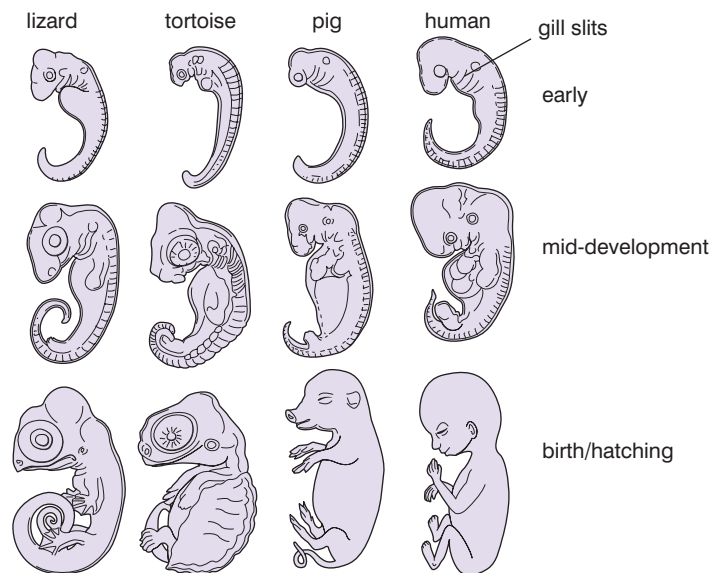
By comparing the anatomy of these limbs, scientists have determined that the basic pattern (called a **pentadactyl limb**) must have evolved just once and that all organisms with this kind of limb are descended from that original type – they share a common ancestor.

However, comparative anatomy needs to be used carefully as evidence for evolution. Sometimes organisms have structures that function in very similar ways. However, morphologically and developmentally these structures are very different. We call these **analogous structures**. Because they are so different structurally, even though they have the same function, they cannot indicate that two species share a common ancestor.

For example, although the wings of a bird and a mosquito both serve the same function their anatomies are very different. The bird wing has bones inside and is covered with feathers, while the mosquito wing has neither of these. They are analogous structures and have evolved separately.

**How does comparative embryology support the theory of evolution?**

Comparative embryology studies the way in which the embryos of vertebrates develop before they hatch or are born. This development shows similarities which supports a common ancestry. For example,



**Figure 4.26** Similarities in development of embryos

early in development, all vertebrate embryos (including you) have gill slits and tails, shown in figure 4.26. However, the 'gill slits' are not gills; they connect the throat to the outside, but in many species they close later in development. However, in fish and larval amphibians they contribute to the development of gills.

The embryonic tail does not develop into a tail in all species. In humans, it is reduced during development to the coccyx, or tailbone. The more similar the pattern of embryonic development, the more closely related species are assumed to be. The similarity in the pattern of development of vertebrates suggests, again, a common ancestor.

You must be careful when describing what comparative embryology shows. It does not show that an embryo is retracing its evolutionary history, as some people, mistakenly, believe.

### How does comparative biochemistry support the theory of evolution?

Various chemicals have been studied in order to find evidence of evolutionary relationships. The idea behind this is that if organisms share very similar molecules and biochemical pathways, then they must be closely related evolutionarily. Chemicals that have been used in such analyses include:

- DNA – the base sequences of DNA from different organisms is compared
- proteins such as:
  - cytochrome c (found in the electron transport chain of respiration) and
  - haemoglobin

which are compared in terms of amino acid sequences.

Species that are closely related have the most similar DNA and proteins; those that are distantly related share fewer similarities. A comparison of DNA sequences shows that it is 99.9% certain that chimpanzees are humans' closest relatives (98% of our DNA is the same as that of chimpanzees).

To measure the similarity of one species' DNA with another species, we use a technique called DNA hybridisation. The technique measures the extent to which a strand of DNA from one species can bind with (or hybridise with) a strand of DNA from another species. In this technique, the double helix of the DNA molecule is heated to separate it into single strands and then the single-stranded DNA (ssDNA) from both species is mixed and the mixture cooled. Although the ssDNA from species A and species B will hybridise (bind) as it cools, it will not do so along all its length. There will be regions that are mismatched (the base pairs are not complementary) and so do not bind and there are techniques available to measure the percentage of this mismatching. The information can then be used to calculate the percentage similarity of the DNA samples.

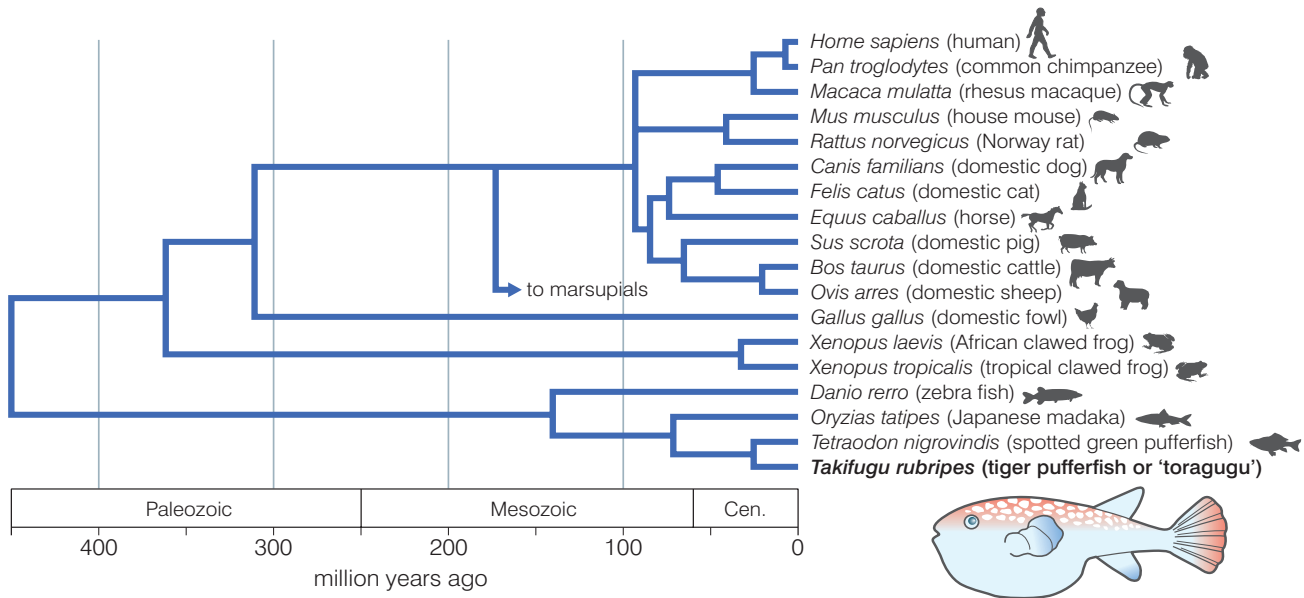
### DID YOU KNOW?

#### Vertebrates have similar patterns of embryological development

All vertebrates have a basic set of genes (called the homeobox genes) that define the basic body plan of a vertebrate. These operate early in development to ensure that a backbone and skull etc. develop. Later, other genes (which are different in different groups) define the development of those features that will make them the species that they are.

### DID YOU KNOW?

We may share 98% of our DNA with chimpanzees, but we share 50% of our DNA with bananas!



**KEY WORD**

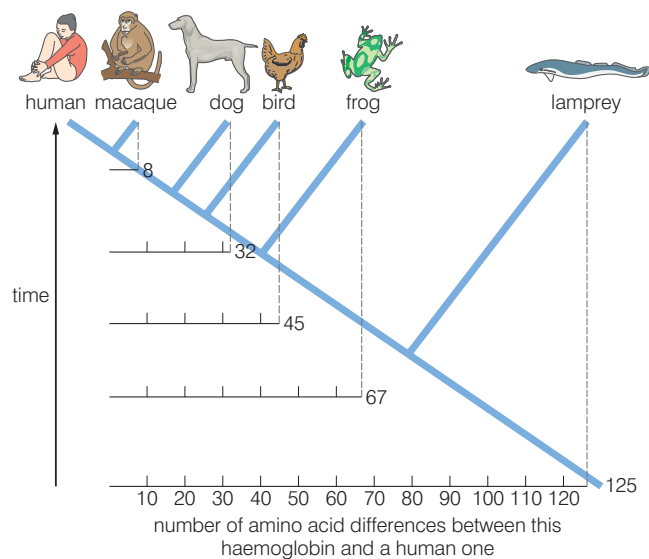
**haemoglobin** the molecule found in red blood cells that carries oxygen to where it is needed

**DID YOU KNOW?**

Differences in DNA are largely due to mutations. By using estimates of mutation rates, biologists can calculate how long it might have taken for a certain number of differences in DNA to have arisen.

**Figure 4.27** A phylogenetic (evolutionary) tree of some animals based on differences in DNA

The **haemoglobin** molecule is similar in all animals that possess it, but there are differences. For example, the haemoglobin of the lamprey (a primitive fish-like animal) has only one polypeptide chain, not four. Most animals have haemoglobin with four chains, but the chains do vary. Figure 4.28 shows the differences in the amino acid sequences of the  $\alpha$  chains of human and several other animals. The diagram is presented in such a way as to show when the different animals may have diverged from the evolutionary line that led to humans.



**Figure 4.28** The evolutionary relationships of some animals shown by differences in haemoglobin

Differences in the amino acid sequence of cytochrome c give a similar picture.

The molecules that are used to show evolutionary relationships are those that are common to large numbers of organisms. But, clearly, haemoglobin analysis cannot be used to include plants and algae in any phylogenetic tree.

### How does plant and animal breeding support the theory of evolution?

For thousands of years, humans have been trying to improve the yields of their crop plants and stock animals. They have done this by **selective breeding**, in which:

- those animals (or plants) that show the desired trait (for example, high milk yield or large number of seeds per pod) are selected and mated, and
- the offspring are monitored carefully and, again, only those with the desired trait are allowed to breed.

Over many generations, selective breeding can bring about significant changes to the organisms involved. One example of this is the modification by selective breeding of the wild pig (wild boar) into the many different varieties of the domestic pig.

If new varieties can be produced by selective breeding (in which humans choose which individuals will 'survive to breed') then natural selection (in which environmental pressures select which will survive to breed) should also be able to produce new varieties and, eventually, new species.

#### KEY WORD

**selective breeding** a technique used to produce organisms with a desired trait by allowing only those organisms with that trait to reproduce



**Figure 4.29** The wild boar has been selectively bred to produce the domestic pig

#### Activity 4.8: The evidence for evolution

Your teacher will divide the class into groups with the following names:

- The Palaeontologists
- The Anatomists
- The Embryologists
- The Biochemists
- The Breeding experts

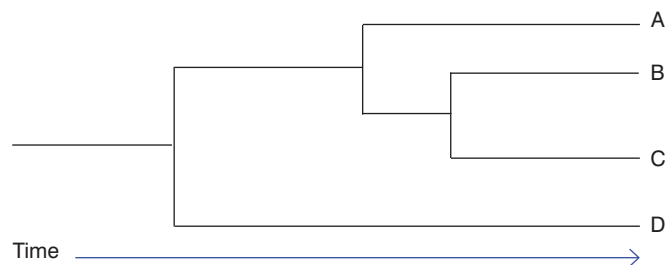
Each group will:

- research its own particular area of expertise and try to find four or five pieces of evidence that support the theory of evolution
- make a poster of the results of their research
- all the posters will form a display 'The evidence for evolution'

### Review questions

Choose the correct answer from A to D.

- In DNA hybridisation, the similarity between DNA of two species is determined by:
  - the extent to which strands of the different ssDNA hybridise (bind) on heating
  - the extent to which strands of the different ssDNA hybridise (bind) on cooling
  - the extent to which strands of the different ssDNA separate on heating
  - the extent to which strands of the different ssDNA separate on cooling
- The diagram shows a phylogenetic tree of four organisms:



Which of the following is false?

- Species A is most closely related to species D.
  - Species C is most closely related to species B.
  - Species B and C are equally related to species A.
  - Species A is most distantly related to species D.
- The theory behind using protein biochemistry to classify organisms is:
    - the more similar the proteins, the more closely related the organisms
    - the extent of the similarity of proteins measures how long ago species diverged
    - similar organisms will have similar proteins because they have similar DNA
    - all of the above

4. A fossil can be:
  - A an imprint of part of an organism
  - B an imprint of a whole organism
  - C a footprint
  - D all of the above
5. Homologous structures:
  - A have a different structure
  - B have a different evolutionary origin
  - C often have a different function
  - D develop differently in the embryo
6. Comparative embryology provides evidence of evolution because:
  - A the embryos retrace their evolutionary history
  - B very different embryos show similarities in their early development
  - C all the embryos have gills
  - D none of the above
7. The sequence of events in fossil formation by permineralisation is:
  - A organism dies – falls into water – is covered with sediment – is compressed by pressure – hard parts of organism replaced by minerals
  - B organism dies – is covered with sediment – is compressed by pressure – falls into water – hard parts of organism replaced by minerals
  - C organism dies – is covered with sediment – falls into water – hard parts of organism replaced by minerals – is compressed by pressure
  - D organism dies – falls into water – hard parts of organism replaced by minerals – is compressed by pressure – is covered with sediment
8. Plant and animal breeding provide evidence of evolution because:
  - A they create new species
  - B they show that natural selection can produce variation
  - C they show that selective breeding can produce new varieties
  - D they create organisms with a better yield

9. Analogous structures:
  - A have the same function
  - B have different internal structures
  - C develop differently
  - D all of the above
10. Fossils over 10 million years old are best dated by:
  - A carbon<sup>14</sup> dating
  - B stratigraphy
  - C potassium–argon dating
  - D none of the above

#### 4.4 The processes of evolution

By the end of this section you should be able to:

- Define natural selection.
- Explain the role in evolution of natural selection (including directional selection, stabilising selection and disruptive selection), isolation and speciation, adaptive radiation (divergent evolution) and convergent evolution.
- List, describe and give examples of the different types of natural selection.

#### KEY WORDS

**natural selection** *the theory that explains the origin of species in terms of survival of those best adapted to a specific environment*

**species** *a group of related organisms that can reproduce with each other so that they produce fertile offspring*

**speciation** *the process by which a new species evolves*

#### What are the different types of natural selection?

The modern view of **natural selection** is stated briefly below:

*Those members of a species which are best adapted to their environment will survive and reproduce in greater numbers than others less well adapted. They will pass on their advantageous alleles to their offspring and, in successive generations, the frequency of these alleles will increase in their gene pool. The advantageous types will, therefore, increase in frequency in successive generations.*

Natural selection is the ‘driving force’ behind evolution. It is the process that brings about changes (over time) in populations that can, eventually, lead to different populations of the same **species** becoming different species.

To appreciate how natural selection can eventually lead to **speciation** (the formation of new species), we must be clear what we mean by a species. Obviously humans are a different species from chimpanzees. But the different races of humans are all members of the same species. Why?



Our current definition of a species is:

*A group of similar organisms with a similar biochemistry, physiology and evolutionary history that can interbreed to produce offspring that are fertile.*

This explains why all humans are members of the same species, but belong to a different species from the chimpanzee.

So how can there be different types of natural selection? All types of natural selection work in the same manner (as described above), but their influence on a population is different. The different types of selection include:

- **directional selection**
- **stabilising selection**
- **disruptive selection**

### What is directional selection?

A feature may show a range of values. Individuals at one extreme could have a disadvantage whereas those at the other extreme have an advantage. For example, thicker fur (longer hair) in foxes is an advantage in a cold climate. Thinner fur in foxes is an advantage in a hot climate. If the environment were to change so that it became significantly colder, or a group of the foxes were to establish a population in a new, colder environment, there would be a selection pressure in favour of the foxes with long fur and against those with short fur.

Over time, selection operates against the disadvantaged extreme and in favour of the other extreme. The mean and range of values shift towards the favoured extreme. The frequency of the alleles causing longer fur will increase.

If you look at the graph carefully, you will see that the whole distribution has shifted. As we might expect, there are now no foxes with the very shortest fur – they could not survive in the new environment. But there are foxes with fur lengths that are longer than any of those in the original distribution. Where have they come from? They must be the result of either:

- new mutations, or
- new combinations of alleles.

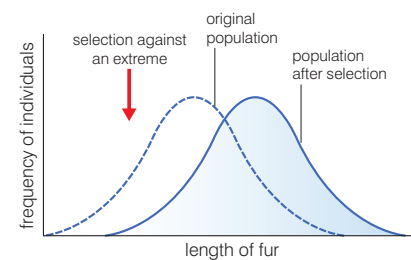
In either case, if they had existed in the original population, they would have been disadvantageous as they would prevent the foxes from being able to cool themselves effectively and so would have died.

### What is stabilising selection?

In a stable environment, individuals at both ends of the range of values for a feature are the least well adapted. Selection often operates against both these extremes to reduce the variability in the population and to make the population more uniformly adapted.

### Are you clear about what makes a different species?

The key is not just that organisms can breed, but that their offspring are fertile (can also breed). A horse and a donkey can breed to produce a hybrid we call a mule. However, mules are almost always sterile – they cannot produce offspring. So horse and donkey must belong to different species.



**Figure 4.30** Directional selection

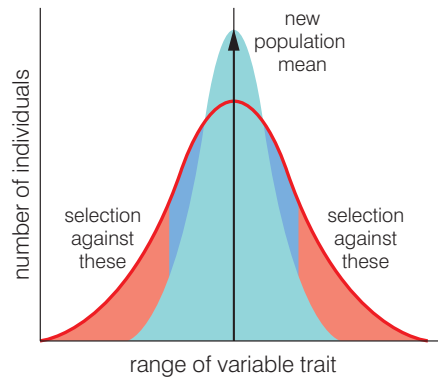


Figure 4.31 Stabilising selection

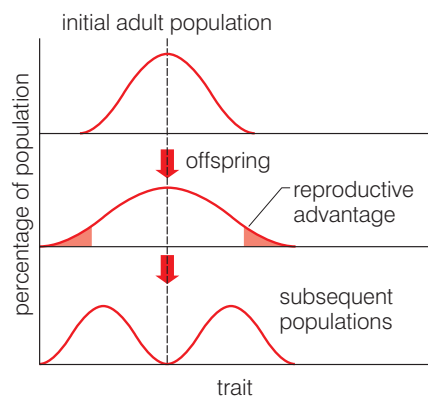


Figure 4.32 Disruptive selection

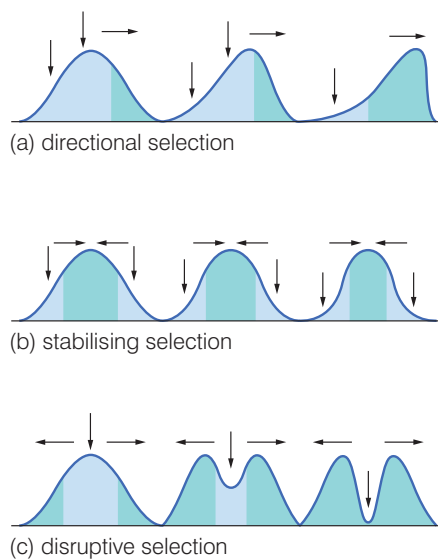


Figure 4.33 A summary of the different types of selection

Birth mass in humans is an example. Babies who are very heavy or very light show a higher neonatal mortality rate (die more frequently at, or just after, birth) than those of medium mass. Over time selection is operating to reduce the numbers of heavy and light babies born. Figure 4.31 illustrates the effect of stabilising selection on a trait.

### What is disruptive selection?

Disruptive selection is, in effect, the converse of stabilising selection. In this instance, individuals at both extremes of a range have some advantage over those displaying the mean value. As a result, the frequency of those individuals at the extremes of the range will increase over time and those in the middle of the range will decrease over time.

This is part of the explanation of the evolution of Darwin’s finches. A finch with an ‘average’ length beak may not be able to obtain insects out of cracks in the bark of trees as well as one with a longer beak. It may also not be able to crush seeds as well as one with a shorter, more powerful beak. Over time, those with the thinner, longer beaks and those with the shorter, more powerful beaks will increase in numbers, whilst those with average length beaks will decrease in numbers.

Figure 4.33 summarises the different types of selection.

### How can natural selection lead to the formation of new species?

Natural selection provides a mechanism by which new populations of a species can arise. But at what point can these populations be considered as distinct species? We have described a species as:

*A group of similar, interbreeding organisms that produce fertile offspring.*

If two populations become so different that individuals from different populations cannot interbreed to produce fertile offspring, then we must think of them as different species. There are a number of ways in which this can occur. The two main ways are:

- **allopatric speciation**, and
- **sympatric speciation**.

As long as two populations are able to interbreed, they are unlikely to evolve into distinct species. They must somehow go through a period when they are prevented from interbreeding. Both allopatric and sympatric speciation involve isolating mechanisms that prevent different populations from interbreeding for a period of time. During this period, mutations that arise in one population cannot be passed to the other. As a result of this, and different selection pressures in the different environments, genetic differences between the two populations increase. Eventually, the two populations will become so different that they will be unable to interbreed and, at this point, we say that they are ‘reproductively isolated’. Effectively, they will have become distinct species.

### What is allopatric speciation?

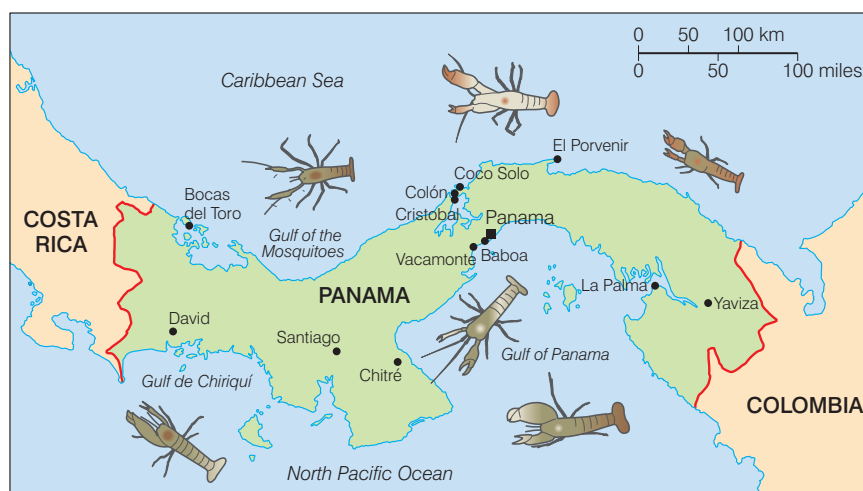
In allopatric speciation, the species become isolated by some physical feature. Examples of this could include:

- a river changing course
- a mountain range being created
- a land mass separating two bodies of water

This is a type of **geographical isolation**. Interbreeding between the populations becomes impossible and speciation could result.

An example of allopatric speciation occurred in the shrimp population of the Caribbean Sea and the North Pacific Ocean, which were once joined. About 3 million years ago, the isthmus of Panama (shown in green in figure 4.34) was formed and separated them, and at the same time created two populations of shrimps, one on either side of the isthmus.

The shrimps from either side of the isthmus still look remarkably similar, but they do not interbreed with each other. They are also extremely aggressive to each other. Two distinct species have evolved from one original species as a result of geographical isolation and allopatric speciation.



### KEY WORDS

**allopatric speciation** occurs when a population from an existing species becomes geographically isolated and the isolated population develops into a new species

**sympatric speciation** occurs when a population from an existing species develops into a new species without becoming geographically isolated from other members of the original species

### DID YOU KNOW?

An **isthmus** is a narrow strip of land connecting two larger land masses, in this case North and South America.

**Figure 4.34** Allopatric speciation in the shrimp population of the North Pacific Ocean and the Caribbean Sea

### What is sympatric speciation?

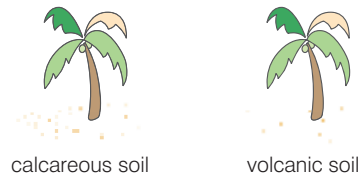
Speciation need not involve physical separation. The two diverging populations may inhabit the same area, but be prevented from breeding in a number of ways, including:

- **seasonal isolation** – members of the two populations reproduce at different times of the year
- **temporal isolation** – members of the two populations reproduce at different times of the day
- **behavioural isolation** – members of the two populations have different courtship patterns

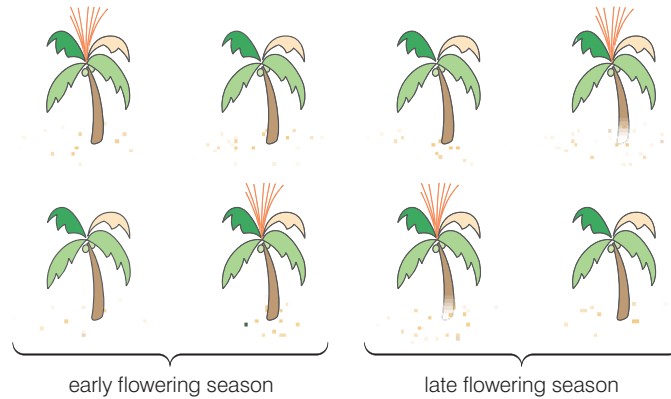
Speciation following any of these methods of isolation is referred to as **sympatric speciation**.

**disruptive selection**

some palms survive better in volcanic acidic soils whereas others perform better in calcareous soils



**seasonal isolation**



palms growing in calcareous soil tend to flower later than palms growing in volcanic soils

**Figure 4.35** Sympatric speciation in the palms of Lord Howe Island

An example of sympatric speciation is found in palm trees growing on Lord Howe Island off the east coast of Australia. The soil on the island is in parts volcanic and in other parts calcareous. Palms growing on the different soils developed different breeding seasons (as a result of nutrient availability at different times). As a result they were reproductively isolated and developed into two different species. Interestingly, the process also involves disruptive selection. Plants in the original population showed tolerance to a range of pH values. However, since the soil was either alkaline (the calcareous soil) or acidic (the volcanic soil), plants at the extremes of the pH tolerance range were at an advantage and were selected for.

**What is polyploidy and why is it important in plant evolution?**

You have already met the terms diploid (chromosomes in pairs – there are two sets of chromosomes in a cell) and haploid (chromosomes are single – there is just one set of chromosomes in a cell). Poly- means many. **Polyploid** cells have many sets of chromosomes per cell – sometimes four sets, sometimes eight or more. Some human liver cells have 92 chromosomes per cell – they are **tetraploid** – they have four sets of chromosomes per cell.

Polyploidy has been important in plant evolution because it has allowed otherwise infertile hybrids to become fertile again. When different species form hybrids, very often the hybrid cannot produce offspring because all the chromosomes cannot form bivalents (homologous pairs) in meiosis. So they cannot form sex cells and cannot reproduce. If the chromosome number were to

**KEY WORDS**

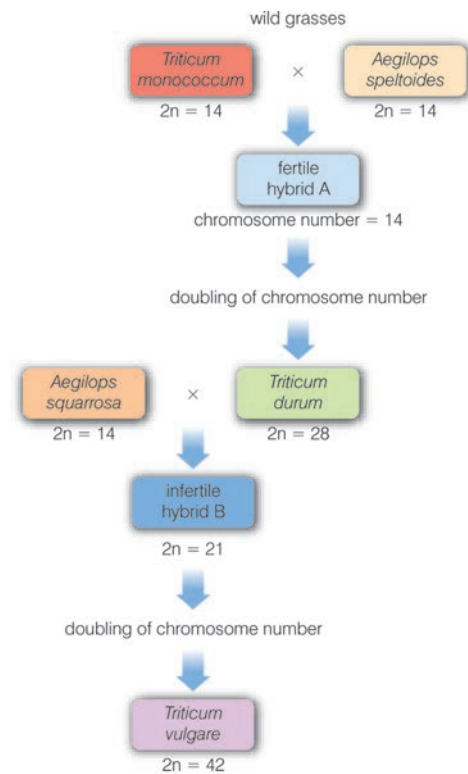
**polyploidy** occurs when an organism has more than two sets of homologous chromosomes

**tetraploid** a tetraploid organism has four sets of homologous chromosomes

double, then all chromosomes are able to form homologous pairs. Meiosis and sex-cell formation can take place and the hybrid is now fertile. Hybridisation and polyploidy have both been important in the evolution of modern wheat from wild grasses. Figure 4.36 shows how.

Hybrid B is infertile because each cell contains one set of chromosomes (7) that came from *Aegilops squarrosa* and one set of chromosomes (14) that came from *Triticum durum*. Clearly, with 21 chromosomes per cell, there are not enough chromosomes for them all to form homologous pairs – even if they were homologous. But when the hybrid doubled its chromosome number, there were two of each chromosome. Now homologous pairs can form in meiosis and the hybrid is fertile.

*Triticum vulgare* is one form of modern wheat. Polyploidy, in addition to restoring fertility to infertile hybrids, often results in bigger plants with more and bigger seeds.



**Figure 4.36** Hybridisation and polyploidy in the evolution of modern wheat

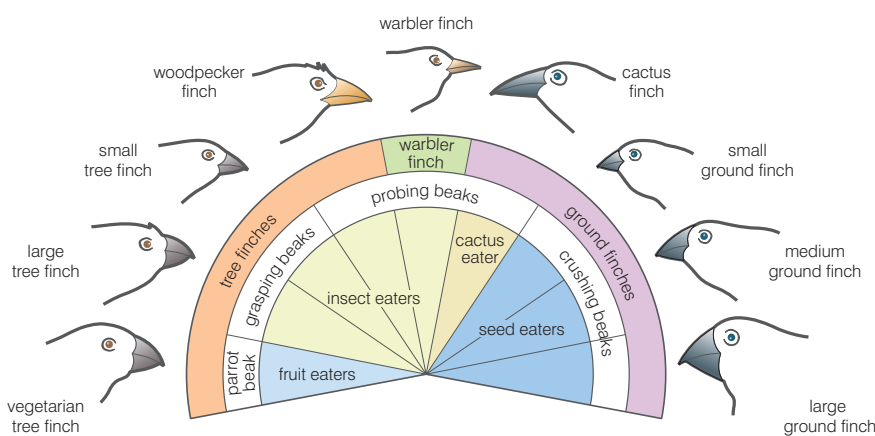
### What are divergent evolution and convergent evolution?

We have looked so far at mechanisms that drive speciation. Now we shall turn our attention to the situations that dictate the lines along which speciation progresses in a given situation.

#### What is divergent evolution?

Divergent evolution is another name for a process we have already met – adaptive radiation. In divergent evolution, a basic type ‘diverges’ along different lines because of different selection pressures in different environments.

If different selection pressures are placed on populations of a particular species, a wide variety of adaptive traits may result. If only one structure on the organism is considered (such as a limb), these changes can either improve the original function of the structure, or they can change it totally. Divergent evolution leads to the development of a new species.



**Figure 4.37** Divergent evolution of finches on the Galapagos Islands

Examples of divergent evolution (adaptive radiation) include:

- the evolution of the different species of finches on the Galapagos Islands
- the evolution of the different forms of the pentadactyl limb

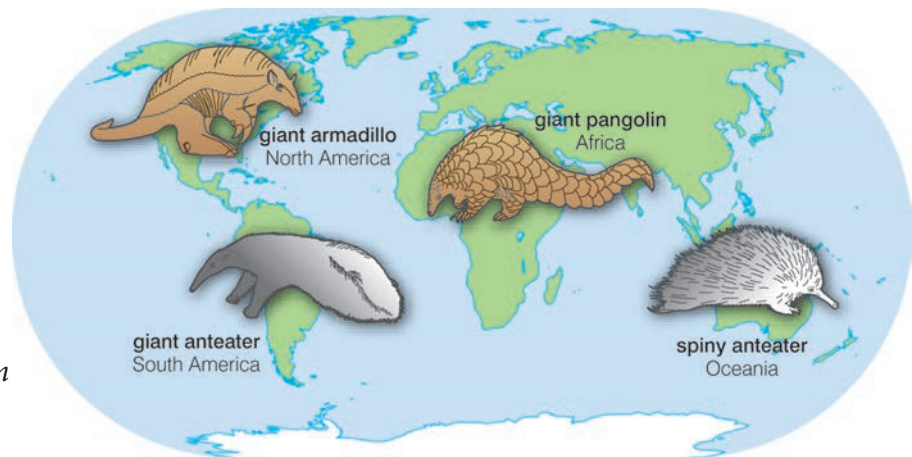
**KEY WORD**

**convergent evolution** *the process by which unrelated organisms evolve similar structures, adapted for the same function*

**What is convergent evolution?**

**Convergent evolution** takes place when different organisms occupy similar niches. The selection pressures on the populations are the same and so similar adaptations evolve over time. One example is the convergent evolution of the giant armadillo, giant pangolin, giant anteater and spiny anteater.

They are not related evolutionarily, but all feed on ants and must obtain the ants from narrow cracks in the ground. The similarity between the four is the result of convergent evolution. The same selection pressures result in similar structures appearing in unrelated organisms. Convergent evolution is also responsible for the wings of a bird, a bat and the extinct pterodactyl.



**Figure 4.38** Convergent evolution in anteaters

**Activity 4.9: Making a fossil****You will need:**

- a small, light plastic container to make the fossil in, such as a yoghurt pot or something similar
- a sponge; natural and synthetic are both fine, but sponges with more holes work better
- some fine sand, enough to half fill your container
- magnesium sulphate
- a saucer or small tray

**Carry out the following:**

1. Create a shape for your fossil by cutting it out from the sponge – it could be a leaf, a shell, a bone or a whole animal.
2. Cut two or three small holes in the bottom of your container. Place it on the saucer/tray.
3. Put sand in the container to a depth of 1 cm.
4. Place your sponge shape on top and cover with another 2 cm of sand.
5. Mix four spoons of bath magnesium sulphate in four spoons of warm water and pour into your container.
6. Allow the mix to sink through the sand then leave it somewhere safe and warm (for example, a window ledge).
7. Add more of the water and salt mix at least once a day for at least five days. The longer you leave it the more 'fossilised' it becomes! (The holes in the sponge trap the salts, mineralising the sponge; as they dry out they solidify to create a fossil. How crumbly this fossil is depends on the consistency of your local sand.)
8. After this time, leave the sand to dry out for two days before removing the 'fossil' sponge. If it is still a little wet, leave the fossil for a few days before handling it.
9. If you have access to a camera, take a photograph of your fossil.

### Activity 4.10: Apes to humans

Your teacher will divide the class into pairs. Each pair will be given an assignment from the list below:

1. Tools and tool use by early hominids before *Homo sapiens*
2. Culture of early hominids before *Homo sapiens*
3. Who's who on the *Homo sapiens* evolutionary tree
4. Life and culture of one of the great apes
5. The preservation of non-human primates in the wild
6. Primates in captivity
7. The common ancestor of humans and chimpanzees
8. The importance of an opposable thumb

Each pair must research their topic and make a presentation to the rest of the class.

### Review questions

Choose the correct answer from A to D.

1. Allopatric speciation involves:
  - A a period when individuals of two populations are prevented from interbreeding
  - B geographical isolation
  - C a period of increasing genetic diversity of two populations
  - D all of the above
2. In directional selection, the selection pressure operates:
  - A in favour of those individuals showing the mean values for a feature
  - B in favour of those individuals at one extreme of the range of values for a feature
  - C in favour of those individuals at both extremes of the range of values for a feature
  - D none of the above
3. Sympatric speciation involves:
  - A a period when individuals of two populations are prevented from interbreeding
  - B geographical isolation
  - C a period of decreasing genetic diversity of two populations
  - D all of the above

**Activity 4.11**

Work in groups to plan an activity, an experiment or a game which would simulate the events of natural selection. You need to think of the organisms involved, the changes that take place in the environment and the way in which natural selection takes place.

An alternative activity would be to make a big chart summarising the different ways in which natural selection can operate to bring about the evolution of a new species.

4. In stabilising selection, the selection pressure operates:
  - A in favour of those individuals showing the mean values for a feature
  - B in favour of those individuals at one extreme of the range of values for a feature
  - C in favour of those individuals showing both extremes of the range of values for a feature
  - D none of the above
5. Convergent evolution can occur when:
  - A different organisms inhabit different environments
  - B different organisms inhabit similar environments
  - C similar organisms inhabit similar environments
  - D similar organisms inhabit different environments
6. Divergent evolution is an alternative name for:
  - A allopatric speciation
  - B adaptive radiation
  - C sympatric speciation
  - D disruptive selection
7. In disruptive selection, the selection pressure operates:
  - A in favour of those individuals showing the mean values for a feature
  - B in favour of those individuals at one extreme of the range of values for a feature
  - C in favour of those individuals at both extremes of the range of values for a feature
  - D none of the above
8. In sympatric speciation, the isolating mechanism could be:
  - A temporal
  - B seasonal
  - C behavioural
  - D any of the above
9. Fertile polyploid organisms could have:
  - A two sets of chromosomes per cell
  - B one set of chromosomes per cell
  - C three sets of chromosomes per cell
  - D four sets of chromosomes per cell
10. The wings of a bird and a pterodactyl are the result of:
  - A convergent evolution
  - B directional selection
  - C stabilising selection
  - D divergent evolution



## 4.5 The evolution of humans

By the end of this section you should be able to:

- Explain how humans have evolved.
- Construct an evolutionary tree of human evolution.
- Explain the importance of Lucy and Ardi in the study of human evolution.
- Discuss some of the controversies surrounding human evolution.

### Who are we and where have we come from?

There is often a lot of very loose language used in describing human evolution. You will hear people say ‘we evolved from monkeys’ or ‘we evolved from apes’ or ‘we evolved from chimpanzees’. None of these statements are accurate. There has been a ‘line of evolution’ for millions of years that has given rise to old world monkeys, new world monkeys, the great apes and the different species of humans that have lived. But, we are *Homo sapiens* and we are the latest of several humans to live on the planet. We have two features in particular that distinguish us from other primates. These are:

- a very large brain, and
- bipedalism – the ability to truly walk on just two legs.

There was a lot of debate amongst biologists as to which of these came first and also about exactly how this ‘evolutionary tree’ has given rise to the various groups. But although they may disagree

### KEY WORD

**Homo sapiens** the species that all humans alive today belong to

### new evolutionary tree for primates

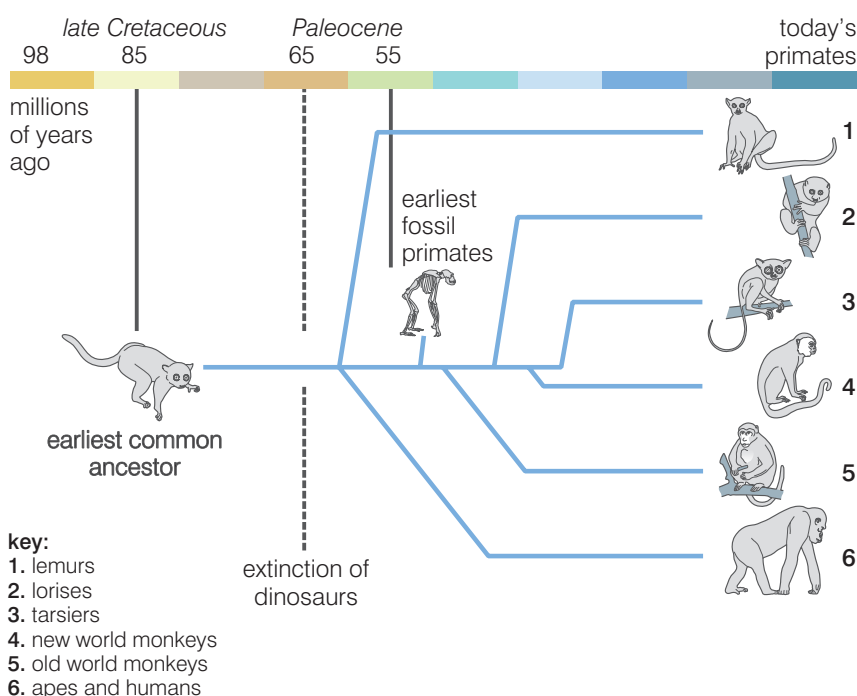


Figure 4.39 The evolutionary tree for modern primates

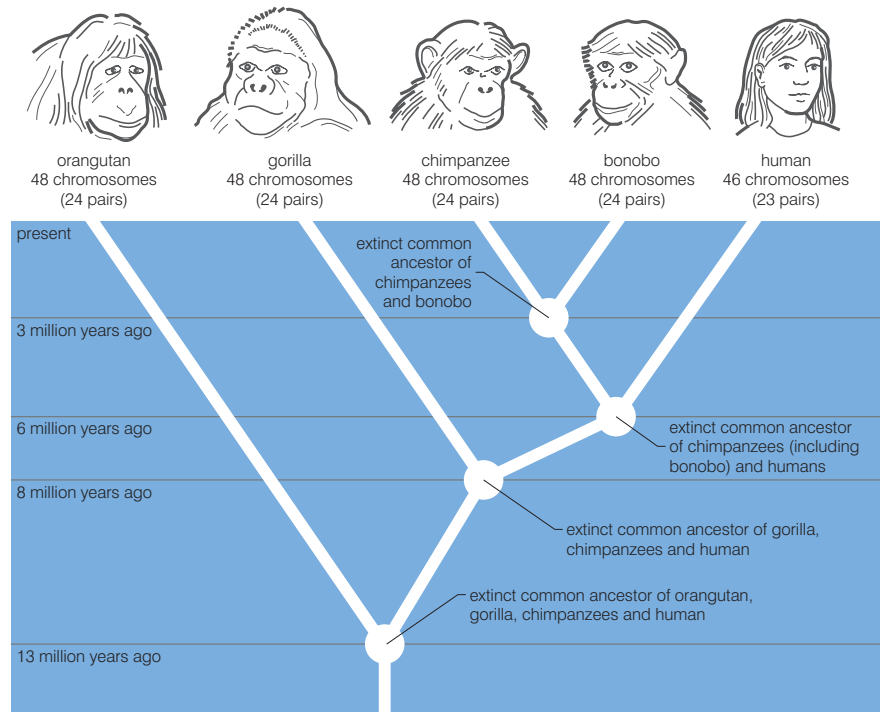
**KEY WORDS**

**genus** (plural **genera**) a group of closely related species

**hominin** any member of the genus *Homo*. This includes modern humans (*Homo sapiens*), neanderthals and *Homo erectus*

**hominid** a group of species that includes all the species belonging to the genus *Homo* along with other species such as *Ardipithecus ramidus* and *Australopithecus afarensis* (*Lucy*)

over the details, they are all agreed about the idea – a line of evolution that has branched to give the different groups of primates (including apes and humans) that exist today and have existed in the not too distant past. Figure 4.40 shows the part of the evolutionary tree of humans and the living great apes in more detail.



**Figure 4.40** The evolutionary tree of humans and the great apes

You can see that at several points there are ‘common ancestors’. These represent branching points in the evolutionary tree. At these points it is assumed that an ancestral type became divided into at least two populations which subsequently evolved along different lines. You can see from this evolutionary tree why statements like ‘humans evolved from chimpanzees’ are inaccurate. Humans and chimpanzees both evolved from a common ancestor that lived about 6 million years ago.

So far in this section, we have talked about ‘humans’ rather than the one specific type of human (ourselves – *Homo sapiens*) that now inhabits the planet. There were other humans before us and, before them, what we might call ‘pre-humans’. All humans belong to the **genus** *Homo*.

Figure 4.41 shows a timeline for the major **hominin** and **hominid** species according to currently available fossil evidence.

Looking carefully at figure 4.41, you begin to see just how important Ethiopia has been in the evolution of humans. Fossils of many of the species along the early part of the timeline were found in Ethiopia. It is indeed the ‘cradle of mankind’.

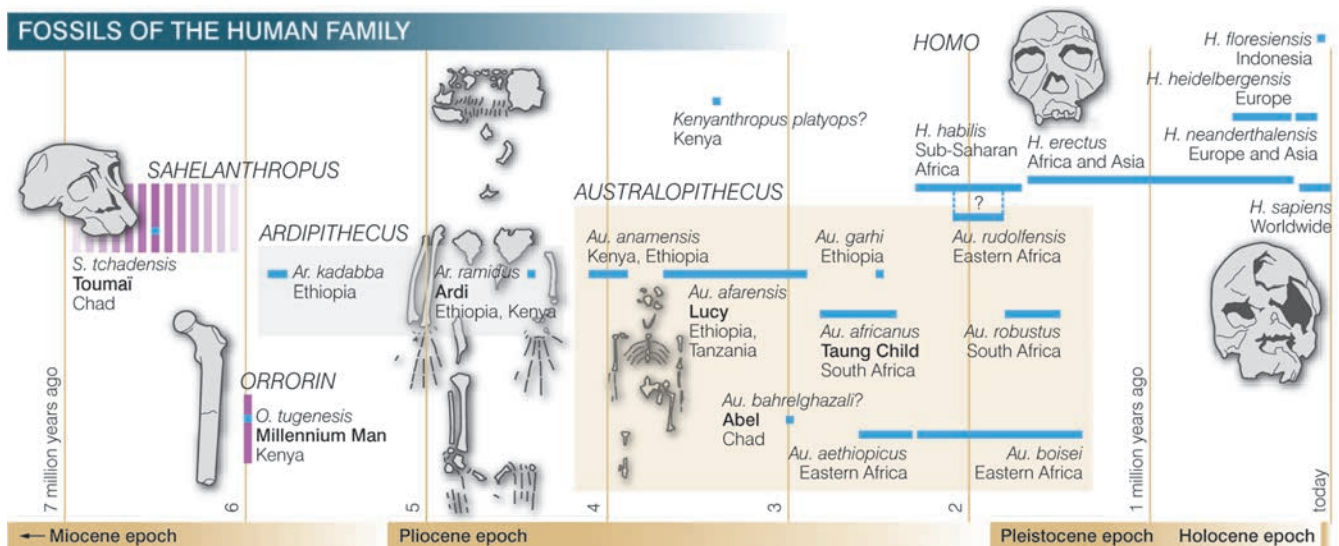


Figure 4.41 A timeline for the major hominin and hominid species

### What is significant about Lucy and Ardi?

Both Lucy and Ardi are important fossils in explaining the evolution of modern humans and chimpanzees from a common ancestor. Lucy was discovered by Donald Johanson and Tom Gray in 1974 at Hadar in Ethiopia. Lucy is a fossil dated at about 3.2 million years. She was an adult female of about 25 years and belonged to the species *Australopithecus afarensis*.

Her skeleton was about 40% completed, an unusually high proportion for a fossil skeleton. Her pelvis, femur (the upper leg bone) and tibia show that she was bipedal (could walk upright on two legs). However, there is also evidence that Lucy was also partly arboreal (tree-dwelling). She was about 107 cm (3'6") tall and about 28 kg (62 lbs) in weight. At the time she was discovered, Lucy represented one of the oldest fossil hominins. The proportions of her humerus and femur were mid-way between those of modern humans and chimpanzees.

#### DID YOU KNOW?

At the time of the discovery, a Beatles song was playing ... 'Lucy in the Sky with Diamonds'. The fossil was named Lucy after the song.

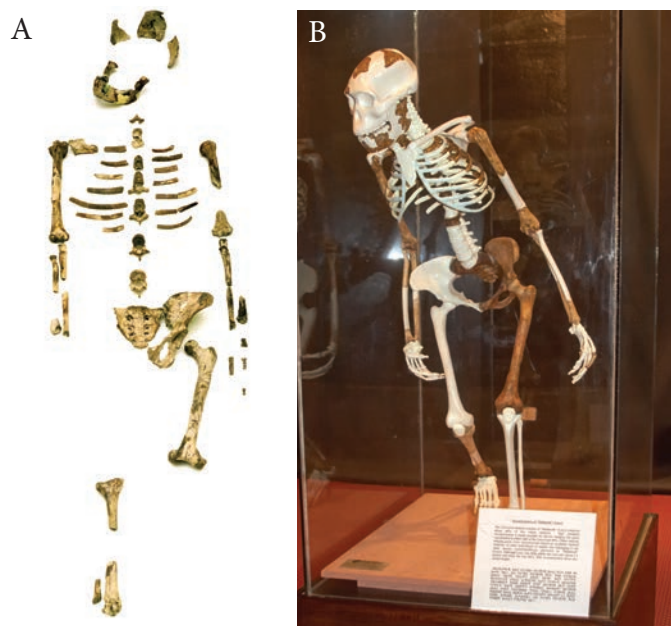
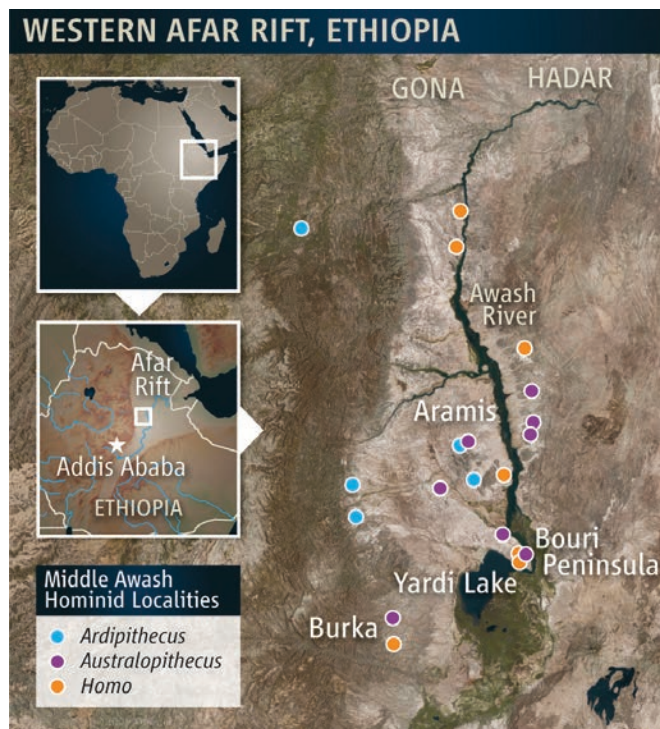


Figure 4.42 A – The original Lucy fossil; B – The Lucy display including reconstructed parts

Lucy had a brain about the same size as that of a chimpanzee, so her discovery was able to settle a debate amongst biologists at the time – which came first, large brain or bipedalism? Clearly bipedalism came before big brains.

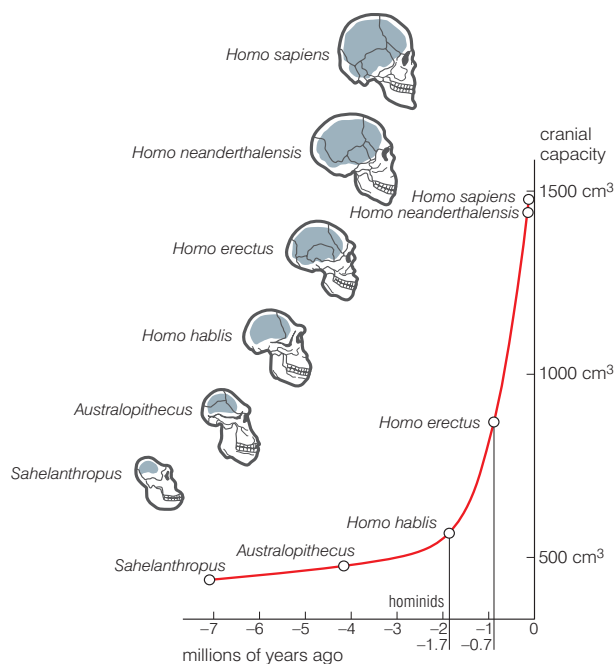
The Ardi fossil (together with many other similar fossils) was first discovered in 1992, in the Afar desert in Ethiopia, but it was only in 2009, after many years’ analysis, that research papers were finally published that gave Ardi a unique position in human evolution.



Ardi was 1.2 million years older than Lucy, was also female and belonged to the species *Ardipithecus ramidus*. One significant feature about Ardi was that she was also bipedal. At 4.4 million years old, Ardi is the nearest fossil to the ‘common ancestor’ of humans and chimpanzees that has so far been found. This find finally proves that the common ancestor of humans and chimpanzees could not have resembled a chimpanzee, as chimpanzees are not truly bipedal.

Figure 4.43 Map showing the area where Ardi was found

Figure 4.44 Brain size in different hominids



### How has brain size changed during human evolution?

During the course of human evolution, the brain has got bigger. We know from comparing fossils that the cranial capacity has increased with each new hominid species that evolved.

However, that is not the whole story. Besides becoming bigger overall, the brain has increased in size as a proportion of body mass. Whereas species of *Australopithecus* have a brain that is between 0.7% and 1.0% of their body mass, modern humans have a brain that is between 1.8% and 2.3% of their body mass. The brain of *Homo sapiens* uses 25% of the resting energy requirement, compared with 8% in the great apes.

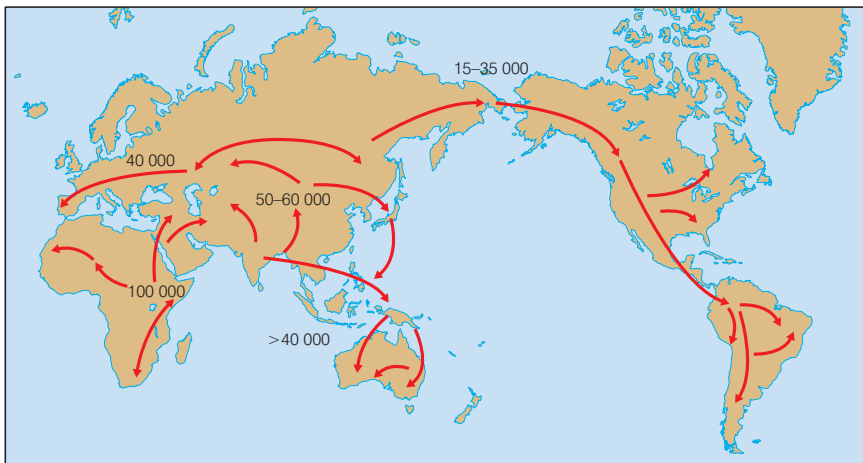
A larger brain allows humans to:

- run faster and in a more upright posture
- plan in advance to avoid attack
- develop and use tools and weapons

These abilities clearly also depend on other physical adaptations such as longer legs, more nimble fingers and a straighter spine, but, without the larger brain to co-ordinate the activities, the physical changes would not confer the same advantage.

### Are we still evolving?

*Homo sapiens* (modern humans) first appeared in Africa and have since migrated to all other parts of the world. Figure 4.45 shows these migratory patterns together with the time (in thousands of years before present) when they took place.



**Figure 4.45** The migration of modern humans out of Africa – it all begins near Ethiopia. Numbers indicate the time (in years) since each stage of the migration.

As humans moved from Africa into different areas of the world, they encountered different environments. Different selection pressures in the different environments resulted in the different human populations evolving along different lines.

For example, as humans encountered colder climates, body features that gave a survival advantage by helping to conserve heat were selected for. These included:

- a shorter, squatter body shape; this reduces the surface-area-to-volume ratio and so reduces the rate of heat loss by radiation
- an increased layer of adipose tissue under the skin to act as insulation
- increased hairiness; this reduces heat loss by convection

Humans have been evolving into different ‘races’ for thousands of years. The classification of these races is difficult and there is some disagreement about their exact nature. One classification is given below. In this there are three main races with several subdivisions. This is based on a recent genetic analysis of the different races.

- **African** (Negroid), 100 million people from Africa and Melanesians of the South Pacific.
- **Eurasian** (Caucasoid), 1000 million people with variable skin colour ranging from white to dark brown. Three subdivisions exist:
  - Nordic – often tall, blonde and narrow-headed; includes people from Scandinavian and Baltic countries, Germany, France, Britain



**Figure 4.46** Example of African features



**Figure 4.47** Example of Eurasian features



**Figure 4.48** Example of East Asian features

- Mediterranean – usually lighter in body build, dark and narrow-headed; includes people from Southern France, Spain, Italy, Wales, Egypt, Jews, Arabs, Afghanistan, Pakistan, India
- Alpine – usually broad-headed, square jaws, olive skin, brown hair; includes people from countries from the Mediterranean to Asia
- **East Asian** (Mongoloid), most numerous of the present-day populations and split into three groups:
  - Eastern Siberians, Eskimos and the Northern American Indians
  - Japanese, Koreans and Chinese
  - Indonesians and Malays

However, this classification does not include the Central African pigmies, the Bushmen and the Australoids.

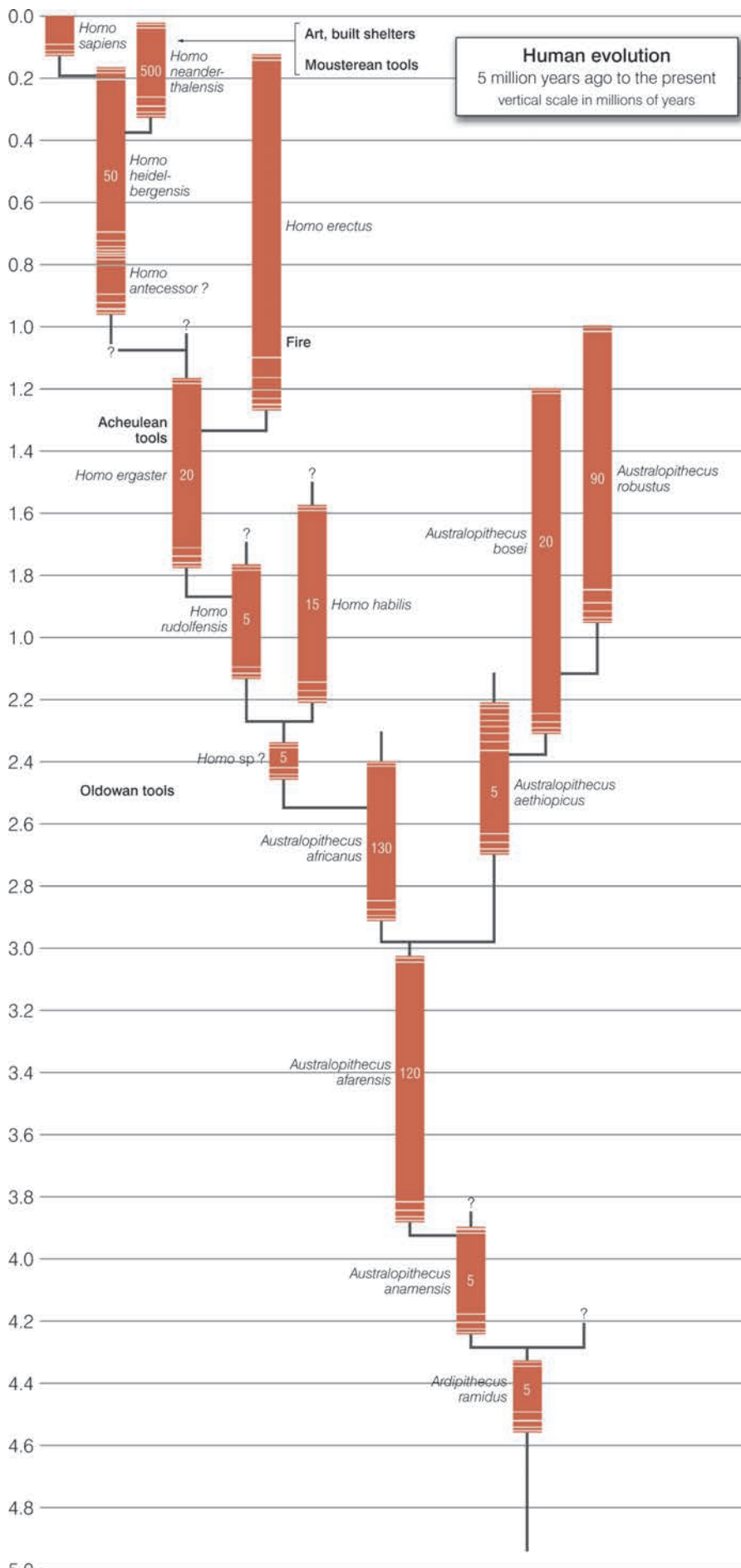
It seems that some thousands of years ago the human populations or races might have been beginning to evolve into separate species. Certainly physical and genetic differences were emerging between the different races. However, our large brain has intervened in two major ways, described below.

- We developed the skill to design and manufacture all kinds of things from buildings to tools to clothes. This effectively allowed us to become able to modify our environment, rather than having to evolve to adapt to it. Anyone can now live perfectly easily in Sweden or any other Nordic country. They must simply wear the right clothes.
- We developed global travel. This has allowed humans of all races to interbreed, throwing many of the genetic differences that have evolved into a huge human melting pot.

We may still evolve into diverse species, but, at the moment, the mechanisms that usually drive speciation have been modified by our large brains.

Figure 4.49 gives a ‘best guess’ as to the evolution of hominids from 5 million years ago to the present day.

There are more species of *Homo* and *Australopithecus* shown in this diagram than have been discussed in the text. You could do a library search to find out about some of them.



### Activity 4.12: Internet search

The origin of modern humans is a fascinating topic and a vast amount has been written about it. You could carry out an internet search to see what else you could find out. You only need search 'human evolution' and you will get a large number of websites to visit. The links printed below will give you a start, if you are uncertain where to go first.

Your teacher may wish you to research a particular aspect of human evolution, in which case you will need to refine your search instruction accordingly.

<http://www.talkorigins.org/faqs/homs/lucy.html>

<http://iho.asu.edu/>

<http://www.time.com/time/health/article/0,8599,1927200,00.html>

<http://www.telegraph.co.uk/science/6251024/New-fossil-moves-story-of-mankind-back-one-million-years.html>

<http://www.becominghuman.org/>

**Figure 4.49** Hominid evolution from five million years ago to the present day

**Activity 4.13**

Ethiopia plays a central role in the story of human evolution. Using this text book, other books and the internet if you have access to it, do as much research as you can on the discovery and importance of Lucy in the story of human evolution. Put together a big classroom display on Lucy based on your findings.

**Review questions**

Choose the correct answer from A to D.

- It is true to say that:
  - modern humans evolved from chimpanzees
  - modern humans evolved from *Homo erectus*
  - modern humans and chimpanzees evolved from a common ancestor
  - modern humans evolved from *Australopithecus robustus*
- Lucy belonged to the genus:
  - Homo*
  - Ardepithecus*
  - Australopithecus*
  - Pan*
- The fact that Ardi was bipedal disproves the idea that:
  - there was a common ancestor of modern humans and chimpanzees
  - the common ancestor of modern humans and chimpanzees was like a chimpanzee
  - the common ancestor of modern humans and chimpanzees was intelligent
  - there was no common ancestor of modern humans and chimpanzees
- A larger brain gave modern humans an increased ability to:
  - run faster with a more upright posture
  - develop and use weapons and tools
  - plan in advance to avoid attack
  - all of the above
- A recent genetic analysis of human populations suggests that there are:
  - five distinct human races
  - five human races with some subdivisions
  - three human races with some subdivisions
  - three distinct human races
- As humans migrated from Africa to colder climates, adaptations that would confer a survival advantage include:
  - a longer, thinner body shape
  - a less hairy body
  - less adipose tissue
  - a shorter, squatter body shape



7. During hominid evolution, brain size has:
- A increased overall but decreased as a proportion of body mass
  - B decreased overall and decreased as a proportion of body mass
  - C decreased overall but increased as a proportion of body mass
  - D increased overall and increased as a proportion of body mass
8. The human races are now less likely to evolve into separate species because:
- A humans are able to travel freely across the globe
  - B interbreeding between different races occurs quite frequently
  - C we are able to modify our environments
  - D all of the above
9. It is true to say that modern humans are:
- A hominins
  - B hominids
  - C primates
  - D all of the above
10. The common ancestor of modern humans and chimpanzees lived about:
- A 2 million years ago
  - B 4 million years ago
  - C 6 million years ago
  - D 8 million years ago

## Summary

In this unit you have learnt that:

- Evolution can be defined as:  
The change in genetic composition of a population over successive generations, which may lead to a population diverging from others of the same species and may lead to the origin of a new species.
- Theories that seek to explain the origin of life on Earth include:
  - special creation theory, in which a 'supreme being' is believed to have created life or directs its creation and evolution

- spontaneous generation theory, in which life is believed to arise from non-living matter; this was finally disproved by the experiments of Francisco Redi and Louis Pasteur
- eternity of life theory, in which life is believed to have existed forever and will continue to exist forever and so no origin is required
- cosmozoan theory, in which either life forms or the organic molecules needed for the origin of life are believed to have been brought to Earth by meteorites and comets
- biochemical origin theory, in which life is believed to have originated as a result of biochemical reactions creating first the necessary organic molecules which then became assimilated into 'pre-cells', which eventually evolved into cells
- Miller's 'spark discharge' experiment showed that the organic molecules essential for life could be synthesised in the conditions on Earth 4.5 billion years ago.
- The oldest photo-autotrophs are the cyanobacteria and they were largely responsible for the increase in free oxygen in the atmosphere.
- In 1809, Lamarck proposed a two-part theory to explain evolution based on:
  - use and disuse
  - inheritance of acquired characteristics
- In 1859 Darwin proposed the theory of natural selection based on:
  - a struggle for existence
  - natural variation in the offspring
- Darwin's theory of natural selection stated that *'Those members of a species which are best adapted to their environment will survive and reproduce in greater numbers than others less well adapted'*.
- Neo-Darwinism takes into account our knowledge of genetics, biochemistry and ethology to modify Darwin's original theory to include the effect of selection on allele frequency and frequency of behaviour patterns.
- Evidence supporting the theory of evolution comes from many areas, including:
  - palaeontology (the fossil record)
  - comparative anatomy
  - comparative embryology
  - comparative biochemistry
  - plant and animal breeding experiments

- Fossils can be dated using:
  - stratigraphy – analysing the sequence and thickness of different layers (strata) of rocks
  - radioactive carbon ( $C^{14}$ ) dating – measuring the ratio of radioactive carbon to normal carbon – is suitable for fossils up to 60 000 years old
  - potassium–argon dating – measuring the ratio of potassium to argon – is suitable for much older fossils
- Homologous structures are evidence of a common origin and divergent evolution.
- Analogous structures are evidence of a different origin and convergent evolution.
- Similar patterns of embryological development in vertebrates suggest a common origin.
- The extent of differences in molecules common to many species (for example, DNA, cytochrome c, haemoglobin) is a measure of their relatedness.
- Selective breeding experiments have shown that genetic and physical modification of species is possible and so should be possible as a result of natural selection (rather than human selection).
- A species can be defined as '*a group of similar organisms with a similar biochemistry, physiology and evolutionary history that can interbreed to produce offspring that are fertile*'.
- The gene pool is the sum of all the alleles of all the genes in a population or species.
- The gene pool is constantly changing as a result of mutations introducing new genes into the population and disadvantageous alleles being lost through natural selection.
- In natural selection:
  - individuals with an advantageous allele survive to reproduce in greater numbers than other types
  - they pass on their advantageous allele in greater numbers than other types
  - the frequency of the advantageous allele in the population increases in the next generation
  - the process repeats over many generations, with the frequency of the advantageous allele increasing in each generation
- In directional selection one extreme of a range of values for a feature has a survival advantage; the range of values for the population shifts towards the extreme with the selective advantage.

- In stabilising selection, the two extremes are at a selective disadvantage compared to those showing the mean values for a particular feature; the range is compressed around the mean.
- In disruptive selection, both extremes have a selective advantage compared with the mean; two distinct types begin to emerge showing the extreme values of the original population.
- If two populations of the same species are isolated for sufficient time, they may become so different genetically as to evolve into separate species.
- Speciation involving geographical separation is called allopatric speciation.
- Speciation involving separation within one area which is a result of different breeding strategies is called sympatric speciation; the different strategies can involve:
  - temporal isolation – reproduction at different times of the day
  - seasonal isolation – reproduction during different seasons
  - behavioural isolation – for example, different courtship/mating behaviours
- Divergent evolution involves adaptive radiation and is the evolution of one basic 'type' into several different 'types' as a result of different selection pressures. Examples include:
  - the divergent evolution of the pentadactyl limb into flippers, legs, wings, etc.
  - the divergent evolution of the beaks (and other features) of Darwin's finches on the Galapagos Islands
- Convergent evolution is the evolution of similar 'types' with similar adaptations from several different original 'types'. Examples include:
  - the elongated 'snouts' (and other features) of the different anteaters of the world
  - the wings of birds, insects, pterodactyls, etc.
- Modern humans and other primates have evolved from a common primate ancestor that lived before the dinosaurs became extinct.
- Modern humans and chimpanzees have evolved from a common ancestor that lived about 6 million years ago.
- Two distinctive features of modern humans are:
  - large brains
  - true bipedalism
- The fossil Lucy was significant because it showed that bipedalism evolved before large brains.

- The fossil Ardi was significant because it showed that the common ancestor of humans and chimpanzees cannot have resembled a chimpanzee.
- Brain size has increased as hominids have evolved.
- Modern humans evolved in Africa, in and near Ethiopia, and have since migrated to all parts of the world.
- Humans evolved into different 'races' because natural selection favoured different features in different environments.
- The three main races of humans are:
  - African
  - Eurasian
  - East Asian
- Despite genetic differences between the races, it seems unlikely that they will evolve into distinct species because of:
  - increasing interbreeding between the races as a result of increased travel
  - increasing ability to modify the environment

### End of unit questions

1. Copy the table below.

Theory	Point(s) in favour of theory	Point(s) against theory
Special creation		
Spontaneous generation		
Eternity of life		
Cosmozoan (panspermia)		
Biochemical (abiogenesis)		

For each of the theories of the origin of life, list at least one point in favour of the theory and at least one point against the theory. You may have to imagine yourself as a 'person of the times' in some cases.

2. (a) Explain what is meant by each of the following terms:
- (i) evolution
  - (ii) convergent evolution
  - (iii) divergent evolution
- (b) How does the fossil record provide evidence for evolution?

3. Both Lamarck and Darwin put forward theories of how evolution may have occurred.
- (a) Copy and complete the table below to compare the two theories.

Aspect of evolution	Lamarck's explanation	Darwin's explanation
How differences emerge		
Inheritance of features		
Why certain types survive		

- (b) Explain how neo-Darwinism has modified Darwin's original theory of natural selection.
4. Biologists investigated populations of stinging nettles in two areas of a large National Park in Japan. Stinging nettles have hairs on their leaves that secrete a chemical when crushed that gives a stinging sensation to animals. There had been a large population of deer in one area for more than 1200 years. The other area had only rarely had deer in it.
- Plants from the nettle population in the area that contained the deer were found to have, on average, 100 times more stinging hairs than the nettle plants in the other area. When seeds from these plants were grown in the laboratory, they developed into plants that also had high numbers of stinging hairs. Seeds from the plants with low numbers of stinging hairs, when germinated, grew into plants that also had low numbers of stinging hairs.
- (a) Explain the evidence that suggests:
- (i) the numbers of stinging hairs per leaf is controlled genetically
  - (ii) the difference in the number of stinging hairs on the leaves of the nettles in the two populations is a result of natural selection.
- (b) Despite their differences, the two populations have not evolved into different species. Suggest why not.
5. (a) In each of the following examples of natural selection, identify:
- the selection pressure (feature of the environment that is selecting for some types and against others), and
  - the type within the population that is best adapted.
- (i) wildebeest hunted by lions
  - (ii) bacteria in a hospital where penicillin is widely used
  - (iii) nettle plants with different-sized leaves in a shaded woodland area.

- (b) Allopatric speciation and sympatric speciation are two processes by which new species can evolve. Explain:
- one similarity between the two processes
  - one difference between the two processes
6. (a) Explain what is meant by the term 'species'.
- (b) King cheetahs have a different pattern of spots from ordinary cheetahs. At first it was thought that they might be a different species. Suggest how:
- the difference in spot pattern might have arisen
  - biologists have been able to show that king cheetahs are members of the same species as other cheetahs
7. The amino acid sequences of one of the polypeptide chains of haemoglobin from nine animals were determined. The results are shown in the table.

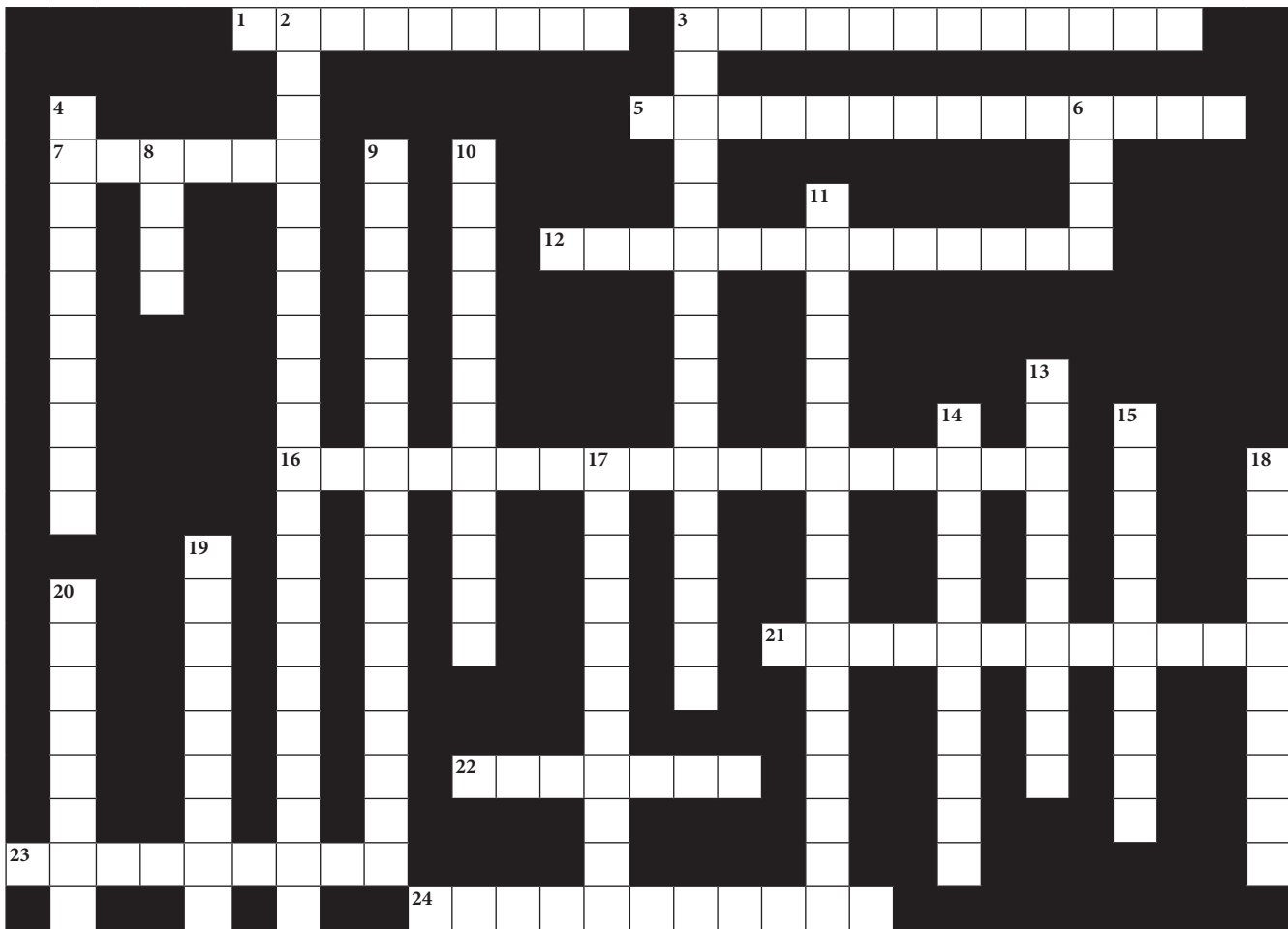
Type of haemoglobin	Number of amino acids different from human haemoglobin
Human	0
Gorilla	1
Gibbon	2
Rhesus monkey	8
Horse	25
Chicken	45
Frog	67
Sea slug	127

- Use the information to draw a phylogenetic tree of the organisms.
  - Cytochrome c can also be used to study evolutionary relationships between organisms. Explain why.
  - It is possible to use DNA hybridisation to suggest relationships between species. Explain why.
8. (a) Explain the importance of each of the following in speciation:
- isolation of different populations
  - mutation
  - selection pressures
  - reproductive isolation

- (b) Describe and explain three ways in which selection pressures in a cold environment could have altered the physical appearance of migrating humans colonising a colder environment.
9. (a) Describe how the experiments of Redi and Pasteur were able to disprove the theory of spontaneous generation.
- (b) (i) Describe the Oparin/Haldane theory of abiogenesis (the biochemical origin of life).
- (ii) Describe three pieces of evidence that support this theory.
10. Write a short essay on human evolution. Include the following aspects of human evolution in the essay:
- the idea of a common ancestor with chimpanzees
  - some of the early humans that have existed
  - the importance of bipedalism and large brain size
  - the significance of the Lucy and Ardi fossils
  - the evolution of different races of humans



Copy the crossword puzzle below into your exercise book (or your teacher may give you a photocopy) and solve the numbered clues to complete it.



**Across**

1. Something that prevents two populations from interbreeding is an ... mechanism (9)
3. Modification of Darwin's theory to take account of genetics and ethology (3-9)
5. Theory of origin of life on Earth that states life has always existed in the Universe and always will (8, 2, 4)
7. Russian biologist who, with Haldane, suggested the theory of abiogenesis (6)
12. The study of ancient life forms, mainly based on the study of fossils (13)
16. Theory of the origin of life that involves a supreme being (7, 11)
21. The dating of a fossil using its position in a sequence of rock strata (12)
22. French biologist who proposed a theory of evolution based on 'use and disuse' and 'the inheritance of acquired characteristics' (7)

23. The theory of the origin of life that suggests that life arrived on Earth from elsewhere in the Universe (9)

24. Modern man (4, 7)

**Down**

2. Theory of the origin of life which states that life can arise from non-living matter (11, 10)

3. Theory of the origin of species proposed by Charles Darwin (7, 9)

4. Type of evolution that results in totally unrelated species evolving similar structures as a result of occupying similar niches (10)

6. A fossil Australopithecine found in Ethiopia in 1974 (4)

8. A fossil Ardipithecine found in Ethiopia in 1991 (4)

9. Process by which one species evolves into many to fill available niches (8, 9)

10. The comparison of the same molecule in different species is comparative ... (12)

11. Form of creationism that tries to disprove evolution by using cell biology and mathematical models (11, 6)

13. Structures with the same basic anatomy but with different functions are said to be ... (10)

14. The type of natural selection in which one extreme is favoured and the other is selected against (11)

15. The process by which new species evolve (10)

17. Droplets that could have been the first 'pre-cells' (11)

18. The study of how embryos develop (10)

19. A process resulting from genetic change in a population over generations leading to the formation of new species (9)

20. All the alleles of all the genes of a population (8)

Contents	
Section	Learning competencies
5.1 An introduction to behaviour (page 231)	<ul style="list-style-type: none"> <li>• Explain what is meant by the term behaviour and describe its types.</li> <li>• Explain the importance of studying behaviour.</li> </ul>
5.2 Innate behaviour (page 238)	<ul style="list-style-type: none"> <li>• Explain what is meant by innate behaviour.</li> <li>• Describe and explain the characteristics of innate behaviour.</li> <li>• Describe and give examples of different types of innate behaviour.</li> <li>• Describe reflex behaviour in humans.</li> <li>• Describe instinctive behaviour in non-human animals.</li> <li>• Describe and explain biological clocks in non-human animals.</li> </ul>
5.3 Learned behaviour (page 246)	<ul style="list-style-type: none"> <li>• List the different types of learned behaviour.</li> <li>• Explain how the learning process takes place in each type.</li> <li>• Describe examples of each type of learning (habituation, classical conditioning, operant conditioning, imprinting, insight learning and latent learning).</li> <li>• Compare innate and learned behaviour patterns.</li> </ul>
5.4 Examples of behaviour patterns (page 256)	<ul style="list-style-type: none"> <li>• Describe and explain courtship, territorial and social patterns of behaviour.</li> <li>• Give examples of each type of behaviour.</li> </ul>

### 5.1 An introduction to behaviour

By the end of this section you should be able to:

- Explain what is meant by the term behaviour and describe its types.
- Explain the importance of studying behaviour.

#### What is behaviour?

Behaviour can be defined in a number of ways, depending on your perspective, or viewpoint. We very often use the term in a 'social' context and speak of 'bad behaviour' or 'good behaviour'. Some definitions of behaviour are listed below.

#### Activity 5.1

Before you study this chapter, work in small groups and brainstorm what you think is meant by the term behaviour. How would you define behaviour? What examples of animal behaviour can you think of? Keep your brainstorm and look back at it when you have completed this chapter.

**DID YOU KNOW?**

A stimulus is a change in the external or internal environment of an organism.

**KEY WORDS**

**receptor** *a cell or group of cells that receives and processes stimuli*

**effector** *any part of an organism that produces a response*

**phototropism** *the tendency for parts of plants to grow towards light (positive phototropism) or away from light (negative phototropism).*

**auxin** *a hormone that helps to produce the phototropic response*

- The observable response a person makes to any situation.
- A manner of acting or conducting yourself.
- The way a person behaves towards other people.
- The actions or reactions of a person or animal in response to external or internal stimuli.
- The responses or reactions or movements made by an organism in any situation.

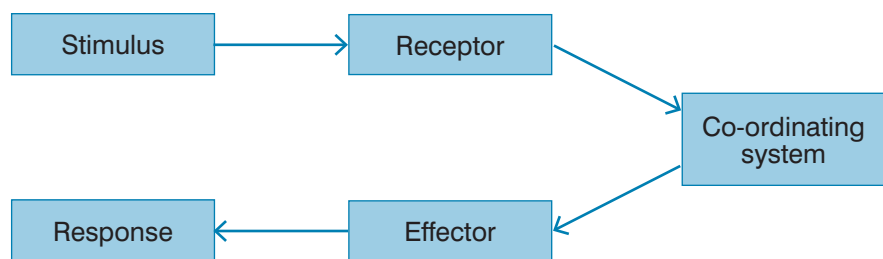
However, from a biological viewpoint, none of these is quite complete. The last two come the closest, but a still better definition would be:

*The co-ordinated response of an organism to an internal or external stimulus.*

For an organism to show a co-ordinated response, then any behaviour must have these components:

- a **receptor** of some kind to detect the stimulus
- an **effector** of some kind to produce the response, and
- some kind of linking system or co-ordinating system that is influenced by the receptor and can influence the effector.

This is represented diagrammatically in figure 5.1.



**Figure 5.1** A generalised model of the components of behaviour

We can now apply this model to specific behaviours in both animals and plants.

**How do plants respond to unidirectional stimuli?**

Everyone has noticed that if you put a plant on a windowsill (where the intensity of the light will be greater on the window side than on the other side), the plant shoots grow towards the window. They grow towards the greater light intensity. This behaviour is called **phototropism**. Plant shoots are positively phototropic because they grow towards light. The response is even more marked in young seedlings.

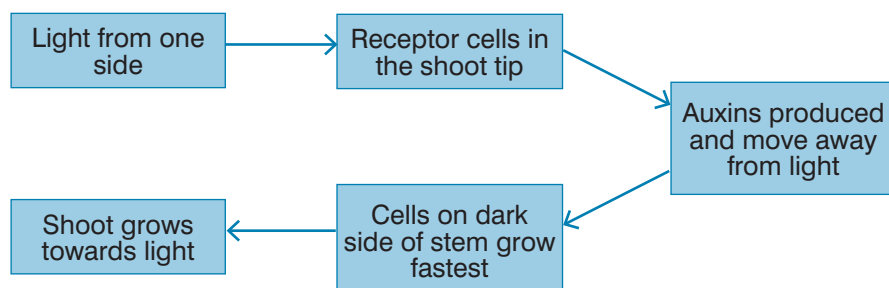


**Figure 5.2** Plant stems grow towards the area of greatest light intensity

The benefit in plant stems growing towards the greatest intensity of light is that stems automatically direct their leaves in this direction as well. This means that the chlorophyll and other pigments in the leaf cells can absorb the maximum amount of light for photosynthesis.

This response is co-ordinated by plant growth substances called **auxins**. These are produced in the shoot tip in response to light and

move downwards and away from light to the 'dark' side of the shoot. The auxins stimulate the shoot cells to divide and enlarge, so growth is greatest on the side away from the light. As this side grows more, it causes the shoot to bend towards the light. Figure 5.3 shows how this fits our general model of behaviour.



**Figure 5.3** Phototropism in plant shoots

Everyone also knows that plant stems grow upwards and roots grow more or less downwards. The unidirectional stimulus producing this response is gravity. The response by plants to gravity is called gravitropism. Plant roots are positively gravitropic, because they grow towards gravity; plant shoots are negatively gravitropic, because they grow away from gravity. This means that the roots will grow towards an environment in which they can anchor the plant, absorb water and absorb mineral ions.

### How do simple animals respond to stimuli?

Just as some plant responses serve to maintain the plant in a favourable environment, some responses of simple animals do the same. Two different types of responses in simple organisms are given below.

- **Taxes** (singular **taxis**), in which the animal moves along a gradient of intensity of a stimulus towards the greatest intensity of the stimulus (a positive taxis) and sometimes away from the greatest intensity (a negative taxis); there is a directional response to a directional stimulus. For example, the unicellular protocystan *Euglena* swims (using its flagellum) towards areas of increased light intensity. This is positive phototaxis and allows the organism to photosynthesise efficiently.
- **Kineses** (singular **kinesis**), in which a change in the intensity of the stimulus brings about a change in the rate of movement, not a change in the direction of movement. For example, woodlice increase their rate of movement in bright light. This increases the probability that they will move into a dark area, where it is usually more humid and they will lose less water.

### How do woodlice respond to a change in the intensity of light?

Woodlice are small land-dwelling crustaceans. There are many different species, but all are quite similar. Because of their flattened shape and small size, they have a relatively large surface-area-to-volume ratio. This means that they tend to lose water quickly

#### Activity 5.2

In people, reflexes are the simplest form of behaviour. List as many simple human reflexes as you can. Plan an investigation into the speed of one of these reflexes.

through their body surface. This happens quickly because they have no waxy cuticle covering their bodies to limit loss of water. They are typically found under logs, stones, bark and amongst leaf litter. These areas all have a more humid atmosphere, which reduces the rate of water loss from the woodlice. They are all also dark areas.

When brought into the light, the woodlice start to move around much more quickly. This increased rate of movement is a response to the increased intensity of light – it is a kinesis. Figure 5.4 shows how this behaviour fits the general model.

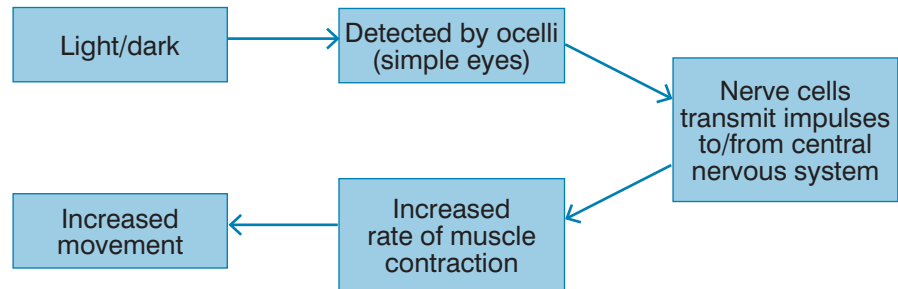


Figure 5.4 The response of woodlice to light

### Activity 5.3: Investigating behaviour in woodlice

The responses of woodlice can be investigated using a choice chamber. A simple choice chamber can be constructed from plastic Petri dishes and perforated zinc gauze to make a floor. The edges of the chamber should be sealed to the zinc floor using Plasticine.

By covering one area of the choice chamber to make it dark and leaving the other area uncovered, the choice chamber can be used to test the preferences of woodlice for light/dark.

- Place 20 woodlice in the choice chamber; 10 in each half of the chamber.
- Cover one area of the choice chamber with black polythene or other opaque material.
- Record the numbers of woodlice in each of the two areas every minute for 10 minutes.

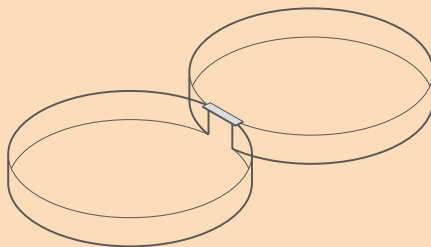


Figure 5.5 A simple choice chamber

Alternatively the areas of the choice chamber could be arranged to have humid or dry atmospheres. This can be done by placing wet filter paper under the gauze in one half and anhydrous calcium chloride (to absorb water vapour in the air) under the gauze in the other half. Then we can proceed as with the light/dark investigation.

However, because we can see both areas in this investigation, we can make an assessment of the kinetic response of woodlice. To do this, we need also to mark the surface of the choice chamber with a grid of squares 1 cm by 1 cm. Then, we can place a woodlouse in each side of the chamber and:

- count the number of squares the woodlouse covers in a 10-minute period (this is a measure of the total movement of the woodlouse)
- count the number of turns made by the woodlouse (this is a measure of how frequently the woodlouse changes direction), and
- repeat the experiments with other woodlice to obtain an average.

The increased movement makes it more likely that the woodlice will, quite by chance, move into dark, humid conditions once more. Once they do, their rate of movement decreases again, making it more likely that they will remain in these more favourable conditions.

### Why is it important to study behaviour?

So far, we have considered behaviour in its widest possible sense, to include the responses of all organisms. For the rest of the unit, we shall confine ourselves to the study of animal behaviour, including human behaviour. So, why study animal behaviour? The study of animal behaviour is often called ethology and the biologists who work in this field are known as ethologists.

Studying animal behaviour is important in its own right as a field of scientific knowledge, just as is subatomic physics. But studying animal behaviour has made many contributions to other areas of science, in particular to the study of human behaviour, but also including:

- **neuroscience**
- the environment and resource management
- animal welfare
- science education

### The impact of the study of animal behaviour on human society

Many problems in human society can be related to the interaction of environment and behaviour, or genetics and behaviour. Social scientists often now turn to animal behaviour as a basis for interpreting human society and understanding possible causes of problems in society. Specific examples include:

- Research by de Waal on chimpanzees and monkeys has illustrated the importance of co-operation and reconciliation in social groups. This work has implications for aggressive behaviour among human beings.
- Harlow's work on social development in rhesus monkeys has been of major importance to theories of child development and attachment formation.
- Basic research on circadian and other endogenous rhythms in animals has led on to research relevant to humans in areas such as coping with jet-lag or shift-working.

### The impact of the study of animal behaviour on neuroscience

Specific examples of this include:

- **neuroethology**: carefully collected behavioural data allows neurobiologists to focus their studies on specific stimuli and specific responses to determine **neural pathways**
- recent work in animal behaviour has demonstrated the influence

#### KEY WORDS

**neuroscience** *the branch of science concerned with the brain and the nervous system*

**neuroethology** *the study of how behaviour is linked to neural pathways*

**neural pathway** *a sequence of nerve cells involved in bringing about a specific behaviour*

#### More about Harlow's rhesus monkeys

In a famous experiment with rhesus monkeys, Harry Harlow investigated whether food or comfort was more important in forming attachments. Infant monkeys were offered the choice of a wire 'mother' that gave milk or a fur-covered 'mother' that gave no milk. They chose comfort over food every time. Research in humans triggered by this shows that feeding is not a major stimulus for attachment formation.



*Figure 5.6 One of Harlow's monkeys and its two 'mothers'*

of behaviour and social organisation on physiological and cellular processes. Variations in social environment can inhibit or stimulate ovulation, induce miscarriages and so on; the neural pathways for these effects are being studied

- other animal studies show that the quality of the social environment has a direct effect on immune system functioning. Again, research is currently being undertaken to discover the neural pathways controlling these responses

### Activity 5.4: Conserving endangered species

If we are to conserve endangered species, we need to know about natural behaviour patterns, such as:

- migratory patterns
- home range size
- interactions with other groups
- foraging demands
- reproductive behaviour

so that we can build up populations again.

Suggest why a knowledge of each of these might help in conserving an endangered species.

### The impact of the study of animal behaviour on management of the environment and resources

The behaviour of animals often provides early clues of environmental damage. Changes in sexual and other behaviour occur much sooner and at lower levels of environmental disruption than changes in population size. Waiting to see if numbers of animal populations are declining may be leaving it too late to take action to save the environment if it is needed.

Specific examples related to resource management include:

- research on how salmon migrate back to their home streams has taught us much about the mechanisms of migration. This has been valuable in preserving the salmon industry in the Pacific Northwest and has also helped in the development of a salmon fishing industry in the Great Lakes of the USA
- knowledge of honeybees' foraging behaviour has given important information about mechanisms of pollination, which in turn has been important for plant breeding and propagation

### The impact of the study of animal behaviour on animal welfare

We now place increased emphasis on the welfare of research and exhibit animals. Animal behaviour researchers look at the behaviour and well-being of animals in the lab and in their natural environment. Such research has ensured reasonable and effective standards for the care and well-being of research animals.

Further developments in animal welfare will require information from animal-behaviour researchers. Improved conditions for farm animals, breeding of endangered species and proper care of companion animals all require information about behaviour patterns.

### The impact of the study of animal behaviour on science education

In some countries there is a concern about the lack of interest in science and the fact that women and minority groups are under-represented in science. Courses at universities in animal behaviour and behavioural ecology often interest students in behavioural biology.

For many students these courses are a first introduction to behavioural biology and may lead on to wider scientific studies.



## Review questions

Choose the correct answer from A to D.

- The correct sequence of the components of any behaviour is:
  - stimulus – co-ordinating system – receptor – effector – response
  - co-ordinating system – receptor – stimulus – effector – response
  - co-ordinating system – stimulus – receptor – effector – response
  - stimulus – receptor – co-ordinating system – effector – response
- The best definition of behaviour is:
  - the pattern of responses shown by an animal
  - the pattern of responses shown by an organism
  - the co-ordinated response of an organism to an internal or external stimulus
  - the co-ordinated response of an animal to an internal or external stimulus
- Examples of behaviour include:
  - the positive phototropism of plant shoots
  - the positive photokinesis of woodlice
  - the negative gravitropism of plant shoots
  - all of the above
- A response to a stimulus that involves increased movement as the intensity of the stimulus increases is called a:
  - tropism
  - taxis
  - kinesis
  - none of the above
- Reasons to study animal behaviour include:
  - findings from animal behaviour experiments may help to predict human behaviour
  - understanding animal foraging behaviour can help in conservation
  - it is a valid study in its own right
  - all of the above

## 5.2 Innate behaviour

By the end of this section you should be able to:

- Explain what is meant by innate behaviour.
- Describe and explain the characteristics of innate behaviour.
- Describe and give examples of different types of innate behaviour.
- Describe reflex behaviour in humans.
- Describe instinctive behaviour in non-human animals.
- Describe and explain biological clocks in non-human animals.

### What is innate behaviour?

The word ‘innate’ literally means ‘inborn’. **Innate behaviour** is behaviour that is present (potentially) at birth or hatching. It does not have to be learned. An example of innate behaviour is shown in figure 5.7. The young herring gull ‘knows’ that if it pecks the orange spot on the beak of the adult gull, it will receive food. It did not have to learn this behaviour.

However, this is not quite the same as saying that the behaviour is coded for directly in the genes. There is not a gene that ‘directly’ codes for ‘pecking mother’s beak’. However, there are genes that code for the development of the appropriate neural pathways to allow the behaviour to be carried out as well as other genes that code for the presence of a mechanism that causes the behaviour to be carried out. This varies according to the type of innate behaviour.



*Figure 5.7 Innate behaviour in herring gulls*

### What types of innate behaviour are there?

There are three types of innate behaviour:

- Reflex actions – these are the simplest of the innate behaviours; a single action is performed in response to a specific stimulus. They are nearly always protective. For example, the withdrawal reflex in which a limb is moved from a stimulus such as heat or pain.
- Orientational – such as the kinesis and taxes of woodlice and other simple animals. These more complex behaviours result in the organism behaving in a way that it is most likely to move from unfavourable conditions and remain in favourable conditions.

- Instinctive behaviours – these often involve the most complex behaviours, but there is always a **fixed action pattern** for each **key stimulus**. Once begun, the fixed action pattern is carried out to completion, even if other stimuli intervene.

Examples of innate behaviour include:

- the withdrawal of your hand from a hot object (reflex)
- blinking when some dust gets in your eye (reflex)
- the kinesis of woodlice in responding to changes in light intensity and humidity (orientational)
- nest-building (instinctive)
- imprinting (instinctive)
- weaving a web (instinctive)

### How are human reflex actions brought about?

There are, broadly speaking, two main kinds of reflex actions:

- Those that involve our special senses (eyes, ears, pressure detectors, etc.) and produce a response by a muscle, called **somatic reflexes**. These include the ‘knee-jerk reflex’ and the ‘withdrawal from heat’ reflex. Many of these reflexes are protective.
- Those that involve sensors in internal organs and produce responses also in internal organs, called **autonomic reflexes**. These include the reflex actions controlling heart rate and breathing rate.

To understand how these two types of reflex action operate, we must look at the structure of the nervous system. Our nervous system is divided physically into two major components:

- the **central nervous system (CNS)**, comprising the brain and spinal cord, and
- the **peripheral nervous system (PNS)**, comprising the cranial and spinal nerves, each containing many sensory and motor neurones.

However, we can also divide our nervous system functionally into:

- the **somatic nervous system (SNS)**, which integrates information from the special senses to produce responses in skeletal muscles, and
- the **autonomic nervous system (ANS)**, which integrates information from receptors in internal organs and produces responses in the same or other organs or glands.

### KEY WORDS

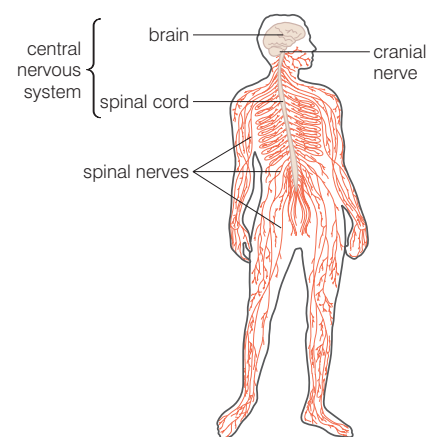
**innate behaviour** *any type of behaviour that does not need to be learned*

**fixed action pattern** *the predetermined behaviour (or behaviours) produced as a response to the key stimulus*

**key stimulus** *the stimulus (out of several stimuli) that triggers the fixed action pattern response*

### More about fixed action patterns

These aren't always quite as 'fixed' as the term suggests. For this reason, some behavioural scientists prefer the terms 'behaviour pattern' or 'behaviour act'. However, the concept of a fixed response is still useful in many cases and so the term is still used.



**Figure 5.8** The components of the nervous system

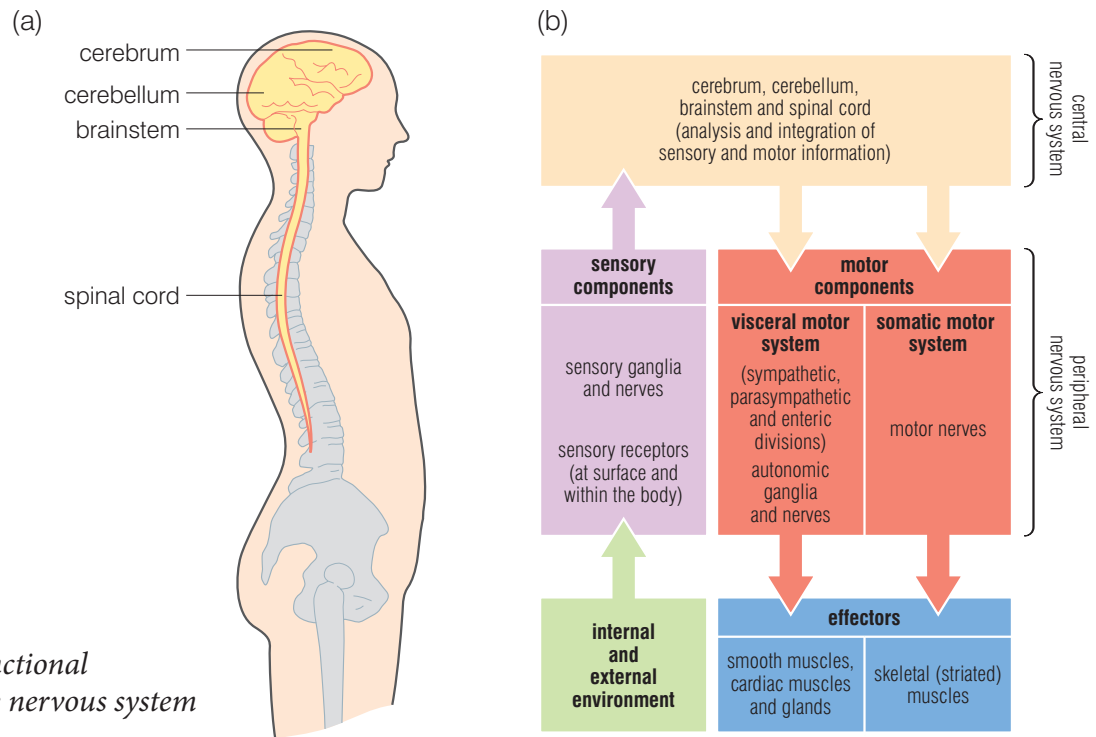


Figure 5.9 The functional organisation of the nervous system

The autonomic nervous system is further subdivided into:

- the **sensory division**, which transmits sensory nerve impulses into the central nervous system
- the **sympathetic division**, which transmits impulses from the central nervous system to the organs, generally preparing the body for ‘fight or flight’ – for example, by increasing cardiac output and pulmonary ventilation, and
- the **parasympathetic division**, which acts antagonistically to the sympathetic branch and prepares the body for ‘rest and repair’, decreasing cardiac output and pulmonary ventilation.

### What are biological clocks?

The term ‘biological clock’ is used to describe some internal regulatory mechanism that controls various cyclical responses in living things. Both plants and animals show yearly, monthly, daily and other cyclical changes that are genetically programmed. Because these clocks are present in so many different types of organisms, biologists believe that they have evolved independently in these groups and are an example of convergent evolution.

Daily rhythms are called circadian rhythms (from the Latin words ‘circa’, meaning about, and ‘dies’, meaning a day). Circadian clocks have two main features:

- They will persist with a period of about 24 hours in the absence of environmental cues.
- They can synchronise to a 24-hour cue, such as the light–dark cycle; this is called entrainment.

The biological clock of mammals and of some other animals is found in a small area of the hypothalamus of the brain, called the suprachiasmatic nucleus. This sends impulses to a gland called the pineal gland, which secretes a hormone called melatonin during the night, which promotes sleepfulness and so controls the sleep-wake cycle. Because of this, if we did not have other cues to wake us and send us to sleep, we might expect to have a different sleep-wake cycle in the summer compared to the winter. In a study of 26 people maintained in a constant environment for six days in summer and six days in winter, the results shown in table 5.1 were obtained.

**Table 5.1** Mean sleep times and wake times in summer and winter

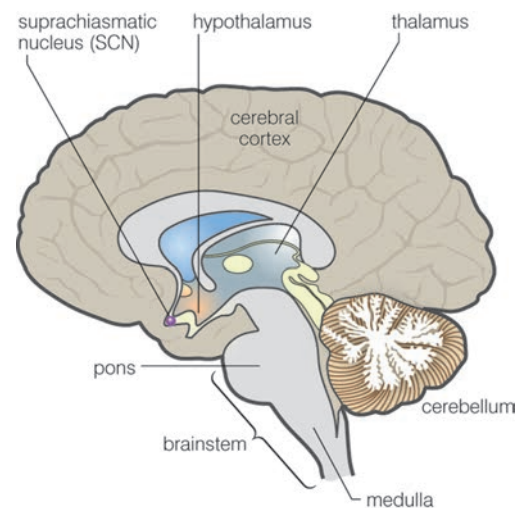
Season	Mean wake time and sleep time	
	Wake time	Bed time
Winter	08.53	23.48
Summer	08.05	23.21
Summer vs winter	48 minutes earlier	27 minutes earlier

Clearly the shorter nights of summer have an effect – but not quite what one would expect. The subjects woke earlier in summer, but also went to bed earlier. However, the shorter nights did result in a reduction of 21 minutes of sleep.

Changes in the light-dark ratio can also control reproductive behaviour on an annual basis. Such rhythms are called circannual (yearly) rhythms. As the day length changes, so will the duration of melatonin secretion. This change in duration links reproductive behaviour in many animals to specific times of the year. Some animals are long-day (summer) breeders and others are short-day (winter) breeders. The point is that it is day length that triggers the changes.

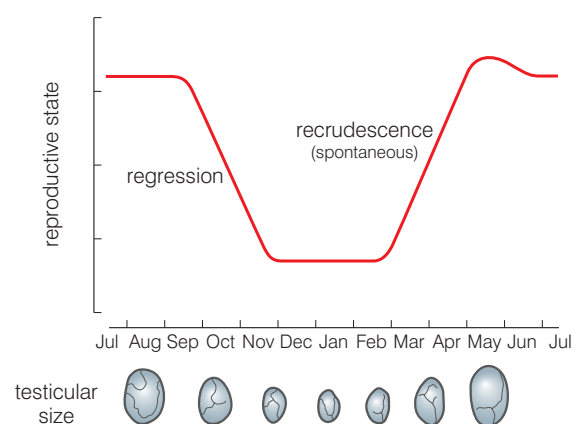
Many other animals show circannual rhythms in behaviours such as:

- migration (for example, swallows)
- hibernation (for example, hedgehogs)
- coat growth (for example, arctic foxes)
- camouflage colouring (for example, arctic foxes)



**Figure 5.10** The location of the supra-chiasmatic nucleus

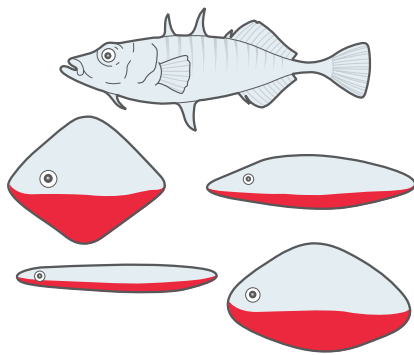
**seasonal cycle of a long-day breeder**



**Figure 5.11** The relationship between size of testis and time of year in a hamster (a long-day breeder)

**KEY WORD**

**imprinting** *the process by which animals acquire their first forms of behaviour, particularly their attachment to their mother*



**Figure 5.12** *The models used by Niko Tinbergen*

**What is instinctive behaviour?**

Instinctive behaviours are pre-programmed patterns of behaviour. They are not just single actions in response to a simple change in the environment like reflex actions. Instinctive behaviours often involve a complex sequence of actions. A good example to illustrate this point is the spinning of a web by spiders. It involves many complex actions, yet the spider does not have to learn how to do it. It spins a perfect web the very first time – as well as every other time afterwards.

Instinctive behaviours have the following characteristics:

- they are common to all members of a species
- they are fully functional the first time they are performed (they require no learning)
- there is a key stimulus that triggers the behaviour
- there is an innate releasing mechanism that links the stimulus to the response (this may be nervous or hormonal)
- there is a fixed action pattern in response to the key stimulus that is always the same, and
- instinctive behaviours are adaptive – they have been retained in the species by natural selection because they confer a survival advantage.

The feeding behaviour of herring gulls discussed at the start of this chapter is an example of instinctive behaviour. The orange spot on the beak is the key stimulus and pecking it is the fixed action pattern. This is not much more complex than some reflex actions. However, aggression in sticklebacks (fish) involves more complex responses. Male sticklebacks are very territorial; they will attack any other male that invades their territory. In some famous experiments, the ethologist Niko Tinbergen was able to show that the key stimulus was the red belly of the entering male. The ‘defending’ male attacked any non-fish model that had red on its ventral (lower) surface.

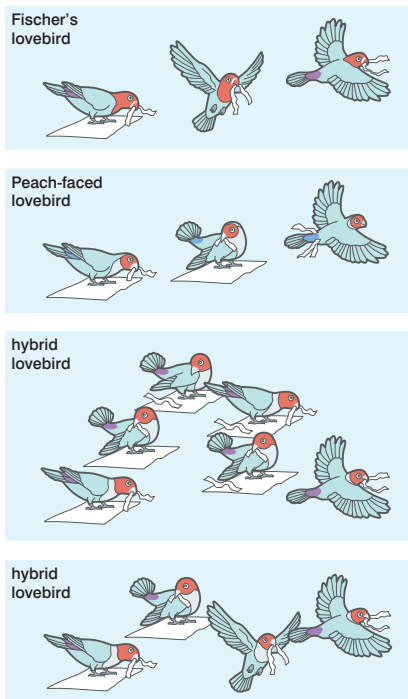
However, it turns out that the red belly – the key stimulus – provokes a very different fixed action pattern in female sticklebacks. They find it irresistible and it stimulates mating behaviour!

There is some evidence that some fixed action patterns can be modified slightly by experience. In an investigation into nesting behaviour in lovebirds, two different species of lovebirds with different nesting behaviours were interbred.

- Female Fischer’s Lovebirds cut long strips of nesting material, which are carried individually to the nest.
- Female Peach-faced Lovebirds cut short strips and carry several at a time by tucking them into their back feathers.

Hybrid females from the crosses exhibited the following behaviours. In the first mating season they:

- cut intermediate length strips
- tried, but failed, to transport them by tucking into back feathers



**Figure 5.13** *Modification of fixed action patterns in lovebirds*

- learned to carry strips in their beaks

In subsequent seasons they always carried the strips in their beaks, but never gave up all ‘tucking’ behaviour.

**Imprinting** is another kind of instinctive behaviour in which the fixed action pattern is for newly born/hatched organisms to imprint on (or become attached to) the first thing they see that has certain general features (those of an adult of its species).

In a famous experiment, Konrad Lorenz split a batch of goose eggs into two batches. One batch was hatched normally by the geese. The other batch was hatched by Lorenz in an incubator. He was the first moving thing they saw ...

There is a ‘time window’ for imprinting to take place. Generally, if it does not take place in the first two days after hatching, then the gosling will not imprint. This, too, may have survival value. If ‘mother goose’ hasn’t appeared in the first two days, imprinting on and following the first moving object after that could be more dangerous than not imprinting at all.

Many evolutionary psychologists believe that a similar pattern of behaviour is found in human infants. It is called attachment formation and involves the formation of a strong emotional bond between an infant and its primary caregiver – often, but not exclusively, the mother. This occurs in three stages:

- 0–2 months – pre-attachment; the infant prefers people to objects but does not really discriminate between different people
- 2–7 months – indiscriminate attachment; the infant begins to show a preference for familiar people, and
- 7 months onwards – true emotional attachment to one person initially, although multiple attachments often form soon afterwards.

According to John Bowlby (who was influenced by the work of Lorenz and other ethologists) attachment formation in humans would also have survival value and natural selection could act to make this behaviour pattern widespread in the species.



*Figure 5.14 Konrad Lorenz and the geese that had imprinted on him*



*Figure 5.15 Infants form attachments with their caregivers*

### Activity 5.5: Classifying innate behaviour

Copy and complete the table to classify the examples of innate behaviour given as:

- somatic reflex
- autonomic reflex
- orientational
- instinctive

Example of innate behaviour	Type of innate behaviour
Increasing breathing rate during exercise	
Maggots moving into a more humid environment	
Geese moving eggs that have rolled out of the nest back to the nest	
Producing tears when dust gets in your eye	
Scratching behaviour in dogs	
Small aquatic crustaceans accumulating at the surface of the water	
A newborn human grasping a rope strongly enough so that he can be lifted by it	

## Review questions

Choose the correct answer from A to D.

- Innate behaviour is best defined as behaviour that:
  - is instinctive
  - involves a fixed action pattern
  - is present at birth and does not have to be learned
  - is reflex
- Which of the following is not an example of innate behaviour?
  - Aggression in sticklebacks.
  - A chimpanzee choosing a long stick over a short one to retrieve food from outside a cage.
  - Nesting behaviour in lovebirds.
  - Imprinting in goslings.
- The central nervous system comprises:
  - the brain and spinal cord
  - the brain and cranial nerves
  - the spinal cord and spinal nerves
  - the cranial nerves and spinal nerves
- Reflex actions:
  - are automatic
  - always produce the same response to the same stimulus
  - are actioned by reflex arcs of neurones
  - all of the above
- Which of the following statements about instinctive actions is not true? Instinctive actions:
  - are innate
  - are adaptive
  - require some learning
  - can sometimes be modified by experience
- Which of the following statements about biological clocks is not true? Biological clocks:
  - control circadian rhythms
  - are the result of divergent evolution
  - control circannual rhythms
  - can be entrained
- Instinctive behaviours always:
  - require a key stimulus
  - show a fixed action pattern response
  - have an innate releasing mechanism
  - all of the above
- An increase in the dark–light ratio can have which of the following effects in mammals? It can cause:
  - a decrease in the secretion of melatonin
  - regression of testes in long-day breeding animals
  - emergence from hibernation
  - none of the above
- Which of the following sequences best describes the events in a somatic reflex action?
  - Receptor is stimulated – impulses along motor neurone from CNS – impulses along sensory neurone to CNS – impulses through relay neurone in CNS – effector produces response.
  - Impulses along sensory neurone to CNS – impulses through relay neurone in CNS – receptor is stimulated – impulses along motor neurone from CNS – effector produces response.
  - Impulses along sensory neurone to CNS – impulses along motor neurone from CNS – impulses through relay neurone in CNS – receptor is stimulated – effector produces response.
  - Receptor is stimulated – impulses along sensory neurone to CNS – impulses through relay neurone in CNS – impulses along motor neurone from CNS – effector produces response.



10. Examples of circannual rhythms include:
- A hibernation
  - B migration
  - C reproduction in short-day breeding animals
  - D all of the above

### 5.3 Learned behaviour

By the end of this section you should be able to:

- List the different types of learned behaviour.
- Explain how the learning process takes place in each type.
- Describe examples of each type of learning (habituation, classical conditioning, operant conditioning, imprinting, insight learning and latent learning).
- Compare innate and learned behaviour patterns.

#### What is learned behaviour?

Before we can answer that question, we need to have a working definition of what we mean by learning. Most biologists would now define learning as:

*The strengthening of existing responses or the formation of new responses to existing stimuli that occurs because of practice or repetition.*

Unlike innate behaviours, learned behaviour patterns are rarely fully functional the first time they are performed. At the very simplest level of learning, trial and error brings about an improvement in the effectiveness of the behaviour pattern. Table 5.2 describes the main differences between innate behaviour and learned behaviour.

#### KEY WORD

**learned behaviour** *behaviour that is acquired through experience (such as trial and error) or by insight*

**Table 5.2** *The differences between innate and learned behaviour*

Innate behaviour	Learned behaviour
Genetically determined and common to all members of a species	The behaviour is changed by, or develops through, experience and may vary from individual to individual
Behaviour is fully functional at the first attempt	The animal develops the behaviour through trial and error or by insight
There is, generally, no modification of the behaviour	The behaviour may be modified by new experiences
Adaptive behaviour that has been retained as a result of natural selection	Behaviour is learned anew by each member of the species and may not be adaptive

**DID YOU KNOW?**

Imprinting is sometimes described as a learned behaviour because repeated exposure is needed to some environmental stimulus to produce the fixed action pattern response. In this sense it is 'learned', even though development of the neural pathways to facilitate the response is innate.

**Activity 5.6: Habituation of mosquito larvae**

You will need:

- a small tank or glass container filled to about 3-4 cm depth with deionised water
- a pipette to transfer the larvae
- a watch
- a lamp

**Investigation 1**

Do mosquito larvae habituate to light?

Procedure:

- Place the lamp above the container, but do not turn on yet
- Place 3 larvae into your container and do not disturb for 5 minutes.
- Focus on one individual which is currently hanging upside down at the water surface and
- turn on the lamp above tank for five minutes,
- after the five minutes is up, turn off lamp
- Estimate how far from the surface the larva moves and measure how long the larva stays away from the surface.
- Leave the lamp off for three minutes
- Repeat steps 3 to 5 another three times

Is there any evidence of habituation?

**Investigation 2**

Do mosquito larvae habituate to sound?

Use the same apparatus and same initial set up as in investigation 1.

Procedure:

- Place 3 larvae into your container and do not disturb for 5 minutes.
- Focus on one individual which is currently hanging upside down at the water surface and tap three times on the side of the container with your fingers
- Estimate how far from the surface the larva moves and measure how long the larva stays away from the surface.
- Wait three minutes
- Repeat steps 3 to 5 another three times

Is there any evidence of habituation?

There are many different kinds of learned behaviour, including:

- habituation
- sensitisation
- insight learning
- associative learning
  - classical conditioning
  - latent learning

## What is habituation?

Habituation is a process which results in a decreased response to a stimulus after repeated exposure to that stimulus over a period of time.

For example, we all have experienced noticing a quite strong smell on entering a room, but some time later we don't even notice that there is any odour present. In this example, your sense of smell has demonstrated habituation. You have stopped responding to the odour even though it is still present.

Habituation can occur at different levels in the nervous system. It can happen because:

- sensory systems may stop, after a while, sending signals to the brain in response to a continuously present or often-repeated stimulus; this is sensory habituation
- the brain still perceives the stimulus is still present, but has simply decided no longer to pay attention

An example of habituation to humans occurs in prairie dogs. Because they have several predators, they give alarm calls when large mammals, large birds or snakes approach them. This allows the group to retreat into their burrows. When populations of prairie dogs are located near areas regularly used by humans, the alarm call is not given when humans pass, despite being large mammals. This is an important example of habituation as the alarm response would waste the time and energy of the group when they could be foraging.

## DID YOU KNOW?

Ethologists often rely on habituation in order to carry out their research effectively. After some time of being among the animals they are investigating, the animals become 'habituated' to them and, largely, ignore them. The ethologists can then carry out their research assuming normal behaviour by the animals.



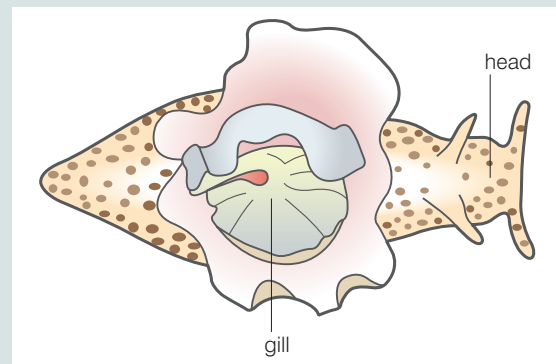
**Figure 5.16** Prairie dogs in their burrow

## Research into habituation using *Aplysia*

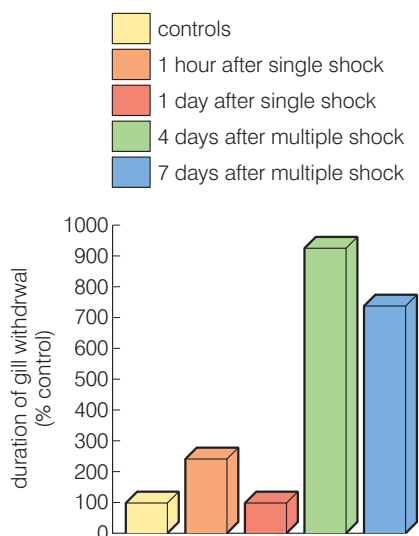
*Aplysia* is a sea slug and is used a great deal in studies of memory and behaviour because its neurones are large and easily observed. In a simple reflex action, a snail ordinarily withdraws its gill if it is touched gently on the siphon. However, repeated stimulation of the siphon results in the gill-withdrawal reflex diminishing in both strength and duration.

If the habituation is just one training session of fewer than 10 stimulations in less than one hour, then the habituation lasts for only a few hours after the training. But if four or more individual training sessions are given, the habituation can last for several weeks. These two forms of habituation have been interpreted as models of short- and long-term memory.

Research has also shown that the nerve network that brings about the response is altered as a result of habituation.



**Figure 5.17** The sea slug *Aplysia*.



**Figure 5.18** The effect of the strength of the initial sensitisation on the duration of the sensitised response in *Aplysia*

Notice that habituation occurs when the stimulus is harmless – a gentle touch on the siphon of *Aplysia*, prairie dogs becoming habituated to the presence of humans who do them no harm, you becoming habituated to a smell which may be unpleasant, but is not harmful.

### What is sensitisation?

Sensitisation is an increase in the response to a *harmless* stimulus when that stimulus occurs *after* a *harmful* stimulus. Again, research with the sea slug *Aplysia* has provided us with a good deal of information about the process. Touching the siphon of *Aplysia* gently causes the animal to withdraw its gill – until it becomes habituated to the harmless stimulus.

However, if the gentle touch on the siphon is preceded by an electric shock (or other mildly harmful stimulus) to the tail, then the gill withdrawal response is much stronger. The events in one pathway of neurones (the painful stimulation of the tail) are clearly affecting the reflex arc that controls the gill withdrawal reflex. The strength and duration of the sensitised response depend on the extent of the initial sensitisation, as figure 5.18 shows.

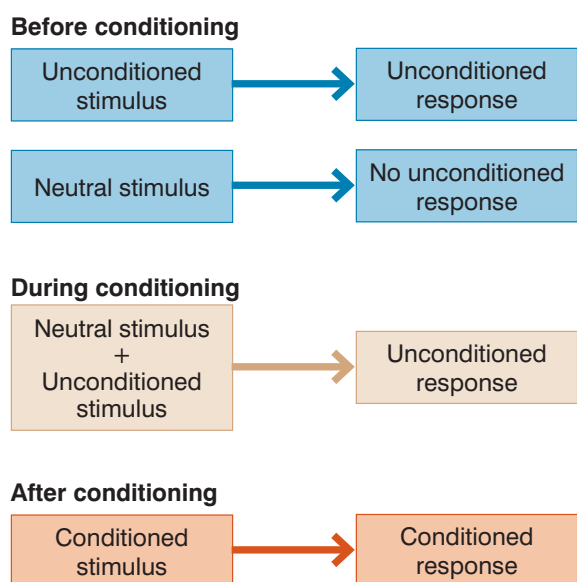
### KEY WORDS

**conditioning** a technique used to get an animal to learn a particular behaviour by associating that behaviour with an event or stimulus (classical conditioning) or with a consequence, such as reward or punishment (operant conditioning)

In higher animals, **peripheral sensitisation** refers to the sensitisation that results from changes in neurones of the peripheral nervous system. **Central sensitisation** refers to the same process occurring in neurones of the central nervous system.

### What is classical conditioning?

In classical **conditioning** a naturally occurring stimulus becomes associated with a different stimulus, which now also produces the same response. It was discovered by the Russian physiologist Ivan Pavlov, who worked with dogs to develop this theory. The various stimuli and responses are:



**Figure 5.19** The phases of classical conditioning

#### The unconditioned stimulus (US)

This ‘unconditionally’, naturally and automatically triggers a response. For example, when you smell a favourite food, you immediately feel very hungry. The smell of the food is the unconditioned stimulus.

#### The unconditioned response (UR)

The unconditioned response is the unlearned response that occurs naturally to the unconditioned stimulus. In the ‘feeling hungry’ example, feeling hungry is the unconditioned response.

#### The conditioned stimulus (CS)

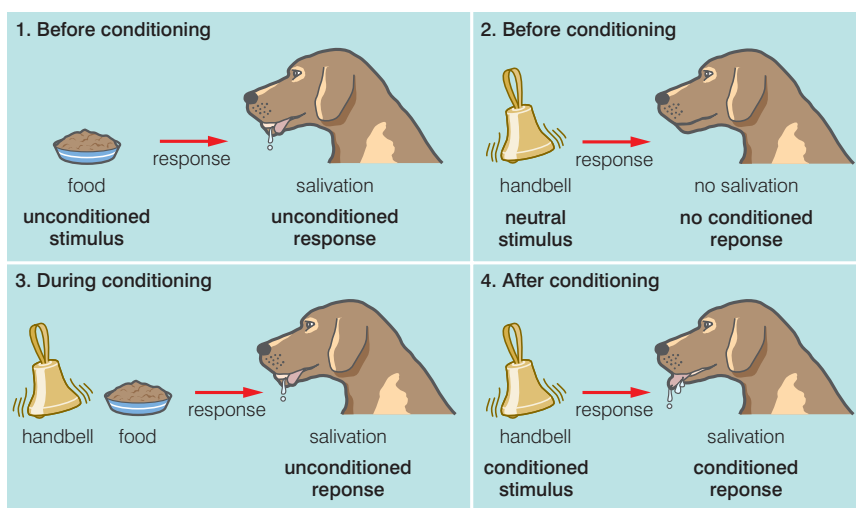
This neutral stimulus does not initially produce the unconditioned response. But, after association with the unconditioned stimulus, it triggers the same response.

### The conditioned response (CR)

The conditioned response is the response to the previously neutral stimulus (which is the same as the unconditioned response to the unconditioned stimulus).

Pavlov's research involved the following phases:

- He fed the dogs at regular intervals to establish a routine; as he fed them, they salivated: this is a natural unconditioned response to the (natural) unconditioned stimulus of food.
- Then, as he fed them, he rang a bell; they continued to produce the same unconditioned response (salivation) as the food was presented and the bell was rung.
- After a period, the dogs salivated when the bell was rung without food being presented; this is now a conditioned response to a conditioned stimulus.



*Figure 5.20* Pavlov's famous experiment on classical conditioning

It is possible to classically condition humans as a famous study called 'Little Albert' demonstrated.

'Little Albert' was an 11-month-old infant, who rarely showed fear of anything. He was not afraid of animals, including the white laboratory rat. He was, however, afraid of loud noises (US). Two psychologists (Watson and Rayner) used his fear of loud noises (UR) to condition Little Albert to fear the white laboratory rat. They showed Albert the rat and at the same time made a loud noise (they banged a steel pipe with a hammer). After only seven pairings of the rat and the loud noise, Little Albert began to cry and try to crawl away (CR) as soon as he saw the rat (CR), even though the rat was not linked with the loud noise on this occasion. He had been conditioned to fear the rat.

If the pairing of conditioned stimulus with the unconditioned stimulus is not maintained, then the conditioned response diminishes and eventually is lost. This is called extinction. Little Albert lost his fear of the white rat after a period of it no longer being paired with the loud noise.

### What is operant conditioning?

Classical conditioning involves modifying an innate response by pairing it with a previously neutral stimulus. Operant conditioning can modify more complex, voluntary behaviours by the animal/person learning to associate the behaviour with certain specific consequences. Figure 5.21 summarises operant conditioning.

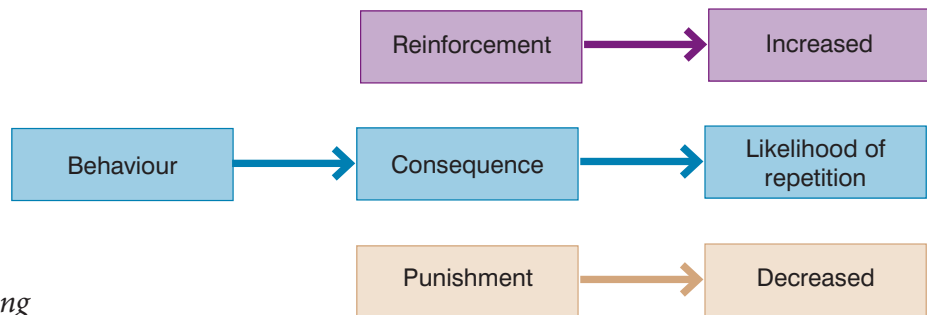


Figure 5.21 Operant conditioning

The term ‘operant conditioning’ was first used by B F Skinner, a behaviourist psychologist who carried out a great deal of pioneering research in this area.

Skinner identified three types of responses that he called operants that can follow behaviour:

- **Neutral operants:** responses from the environment that neither increase nor decrease the probability of a behaviour being repeated.
- **Reinforcers:** responses from the environment that increase the probability of a behaviour being repeated, reinforcers can be either positive or negative.
- **Punishers:** responses from the environment that decrease the likelihood of a behaviour being repeated.

#### Activity 5.7: Behaviour

Think carefully about the way in which your behaviour is controlled and modified by others.

Give three examples of your behaviour that you consider to be the result of classical conditioning and three that you consider to be the result of operant conditioning.

#### DID YOU KNOW?

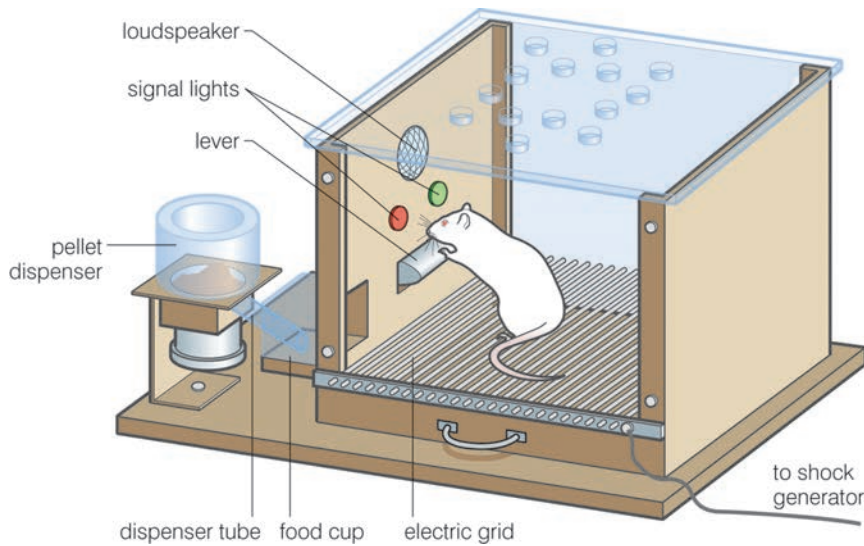
##### Behaviourist psychologists

These psychologists are more concerned with the scientific measurement of observed behaviours rather than with internal processes such as thinking and emotion. There are several basic assumptions in behaviourism:

- When we are born, our minds are a blank slate.
- There is little difference between the learning that takes place in other animals and that which takes place in humans.
- All behaviour, no matter how complex, is the result of a stimulus–response association.
- All behaviour is learnt from the environment (this includes the actions of other people).
- We have no free will; a person’s environment determines their behaviour.

How far do you agree with this? Try to justify what you think.

Skinner carried out much of his research on rats and other animals using what is now called a Skinner box. One variant of the Skinner box is shown in figure 5.22.



**Figure 5.22** A Skinner box

The Skinner box has various signal stimuli that include:

- different coloured lights
- a speaker to deliver a sound stimulus
- an electric grid in the floor to deliver a mild electric shock

There is also a lever that the animal can press, which is linked to the delivery of pellets of food. The animal can be conditioned in several ways, such as by:

- simply learning that pressing the lever will result in food being delivered – the ‘pressing action’ is reinforced by the reward of food
- only pressing the lever when either light is lit up, resulting in the reinforcement of food being delivered
- only pressing the lever when one of the lights is lit; the other is linked to the electric shock system. The ‘punishment’ of the shock on pressing this light results in the behaviour being diminished or extinguished

We can all think of examples of how our own behaviour has been affected by reinforcers and punishers. For example, many people start to smoke so that they will be accepted by a certain peer group. Acceptance by this peer group acts as a positive reinforcer for the smoking and, unfortunately, is often a much stronger influence than other advice and punishers.

Animal trainers use a technique called shaping, which is based on operant conditioning, to train animals to perform in specific ways. It is often not possible to reward the desired behaviour at the outset, because it doesn’t exist. Trainers look for a natural behaviour that, if modified, could lead to the desired behaviour and reward this. They then reward a slight modification of this behaviour that is nearer to the desired behaviour, but not the natural behaviour itself. Each step

### DID YOU KNOW?

Both classical and operant conditioning are sometimes referred to as associative learning because the animals learn to modify their behaviour as a result of either associating two different stimuli or associating particular behaviour patterns with operant responses.

in the learning process is called an approximation. An animal may be reinforced for each successive approximation towards the final goal of the desired trained behaviour. Specific examples of where shaping is used include:

- training guide dogs for the blind
- training horses
- training dolphins and killer whales at marine parks
- training zoo animals

### What is latent learning?

The word ‘latent’ means ‘hidden’ – so we are talking about ‘hidden learning’ or learning that is not apparent as it takes place. Latent learning happens when the brain acquires knowledge at a certain time, without reinforcement, but does not use it until later, at a time when that knowledge is needed.

An example of this could be:

One teacher drives another to school every day. Then, on one day, the ‘driver’ is ill. The other teacher drives himself to school without getting lost. This is an example of latent learning. He learned the route to the school without reinforcement, but never had to use it until the usual driver was ill.

Edward Tolman, a behaviourist psychologist, conducted an experiment with rats in 1938. He placed three groups of rats in a maze and observed how they behaved over a two-week period.

- The rats in group 1 always received a food reward when they reached the end of the maze without wandering down dead ends; they soon did this regularly.
- The rats in group 2 never received a food reward and seemed like they followed no particular path through the maze, although they did sometimes reach the end.
- The rats in Group 3 were treated in a different way at different times of the experiment:
  - for the first 10 days of the experiment, like group 2 they received no food reward even if they did reach the end of the maze and behaved in a similar manner to group 2
  - on the eleventh day, Tolman placed food in the maze, and
  - on the twelfth day, the rats from group 3 were doing as well as the rats from group 1, which had been rewarded with food from the very beginning of the test; it appears that they had learned to go to the end of the maze without reinforcement, but did not desire to until there was some reason (the food).

The rats from group 3 used latent learning since they did not immediately display the same performance as the rats in group 1.

In other experiments, Tolman was able to demonstrate that the rats were building a ‘cognitive map’ of the maze. This means that they

### Activity 5.8

Latent learning is an important part of how we behave. Make a list of as many examples of latent learning as you can think of. Share your list with a partner and see how many different ideas you have had.



were storing information, without reinforcement of the structure of the maze. In the maze shown in figure 5.23, the rats quickly learned that the shortest route to the end of the maze was path A. They also ‘knew’ that if:

- path A was blocked at X, then the new shortest path was path B
- path A was blocked at Y, the new shortest path was path C

It is important to note that, although there was food at the end of the maze, this could not act as a reinforcer for the building of the cognitive map. It only gave a ‘reason’ to get to the end of the maze.

### What is insight learning?

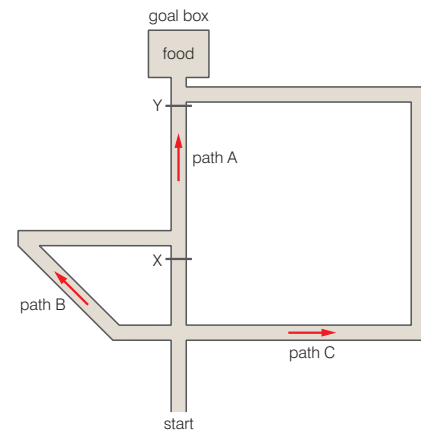
This is very different from the trial-and-error learning that is often an important part of learning through operant conditioning. Insight learning involves finding solutions to problems that are not based on actual experience (as with trial and error) but on ‘trials’ occurring mentally. Often the solution is learned suddenly, such as when a person has been trying to solve a problem for a period of time and suddenly the solution appears almost ‘out of nowhere’. The ‘eureka’ moment.

Much of the pioneering research on insight learning was carried out by Wolfgang Kohler, working with chimpanzees.

For the experiments, the chimpanzees were placed in an enclosed area. Kohler placed desirable ‘lures’ such as fruit outside the enclosure and out of their reach. He placed a variety of objects that could be used to obtain it inside the enclosure. The chimpanzees had to work out a way of using one or more of the objects to obtain the ‘lure’.

They were more successful in this than Kohler had anticipated. The chimpanzees learned to use boxes to obtain bananas placed on the top of the enclosure. They dragged them under the banana and then climbed on them to reach the fruit. They became quite accomplished builders, piling box on box to erect structures with a height of four boxes.

Some of the chimpanzees learned how to make or modify suitable tools from the materials they were given. One chimpanzee, Sultan, was particularly gifted in this. Sultan was given the problem of obtaining a banana far out of reach. There were two hollow bamboo sticks in his cage, but neither was long enough to rake in the lure. After many attempts to reach the banana with one stick or the other, he sat and looked at the sticks. Suddenly Sultan hit upon the solution. He pushed the thinner of the two sticks into the hollow inside of the thicker one and then drew the banana towards himself, his reach now enlarged by the length of two sticks. Eureka!



**Figure 5.23** One of Tolman's mazes



**Figure 5.24** A chimpanzee assesses the problem



**Figure 5.25** Through ‘building’ the chimpanzee achieves his goal

### Review questions

Choose the correct answer from A to D.

1. Which of the following statements about learned behaviour is *not* true? The behaviour is:
  - A fully functional the first time it is performed
  - B acquired anew by each member of the species
  - C modified by experience
  - D developed by trial and error or insight
2. In Pavlov's experiment on the classical conditioning of dogs, the ringing of the bell represents:
  - A the conditioned stimulus
  - B the conditioned response
  - C the unconditioned response
  - D the unconditioned stimulus
3. Which of the following are examples of learned behaviour?
  - A Classical conditioning
  - B Operant learning
  - C Innate behaviour
  - D Insight learning
4. Insight learning involves:
  - A trial and error
  - B innate behaviour
  - C operant conditioning
  - D none of the above
5. Latent learning is different from learning through operant conditioning because it:
  - A is a kind of innate behaviour
  - B does not require any input from the environment
  - C does not require reinforcement
  - D is a kind of insight learning
6. Operant conditioning differs from classical conditioning in that:
  - A classical conditioning involves modifying innate behaviour whereas operant conditioning may involve modifying learned behaviour
  - B classical conditioning does not involve rewarding behaviour but operant conditioning may

- C classical conditioning involves associating two stimuli whereas operant conditioning involves associating a behaviour and a consequence
- D all of the above
7. Which of the following is not one of the assumptions of behaviourist psychology?
- A All behaviour is learnt from the environment (this includes the actions of other people).
- B All behaviour, no matter how complex, is the result of stimulus–response association.
- C The learning that takes place in other animals is fundamentally different from that which takes place in humans.
- D When we are born, our minds are a blank slate.
8. Which of the following forms of learning is mainly used in shaping animal behaviour?
- A classical conditioning
- B operant conditioning
- C latent learning
- D insight learning
9. When Sultan the chimpanzee solved the problem of reaching a banana with two bamboo canes, this was an example of insight learning because:
- A it demonstrated species specific behaviour
- B it was the result of conditioned reflexes
- C he solved the problem mentally when doing something not directly related to reaching the banana
- D it involved hours of trial and error
10. The behaviour of the rats in a Skinner box shows operant conditioning because they may:
- A associate pressing a lever with reward (positive reinforcement)
- B associate pressing the lever when only one light flashes with reward (positive reinforcement)
- C not press the lever when one light flashes because it is linked with an electric shock (punishment)
- D all of the above

**DID YOU KNOW?**

Geese and swans typically form pair bonds that last for life, not just for the period necessary to raise young.

**5.4 Examples of behaviour patterns**

By the end of this section you should be able to:

- Describe and explain courtship, territorial and social patterns of behaviour.
- Give examples of each type of behaviour.

**Pheromones**

This is yet another term derived in part from a Greek word and translates as ‘hormone bearer’. It is a chemical secreted by one animal, usually the female, to produce a behavioural response in another. There are many different pheromones, including:

- alarm pheromones that are secreted by animals when attacked and produce the response of flight or aggression by others of the same species
- releaser pheromones that are highly volatile and can attract a mate from a distance of two miles or more
- territorial pheromones that are used to mark the boundaries of a territory by the owner; dog urine contains a powerful territorial pheromone
- sex pheromones that signal the availability of a female for mating

**What is courtship behaviour?**

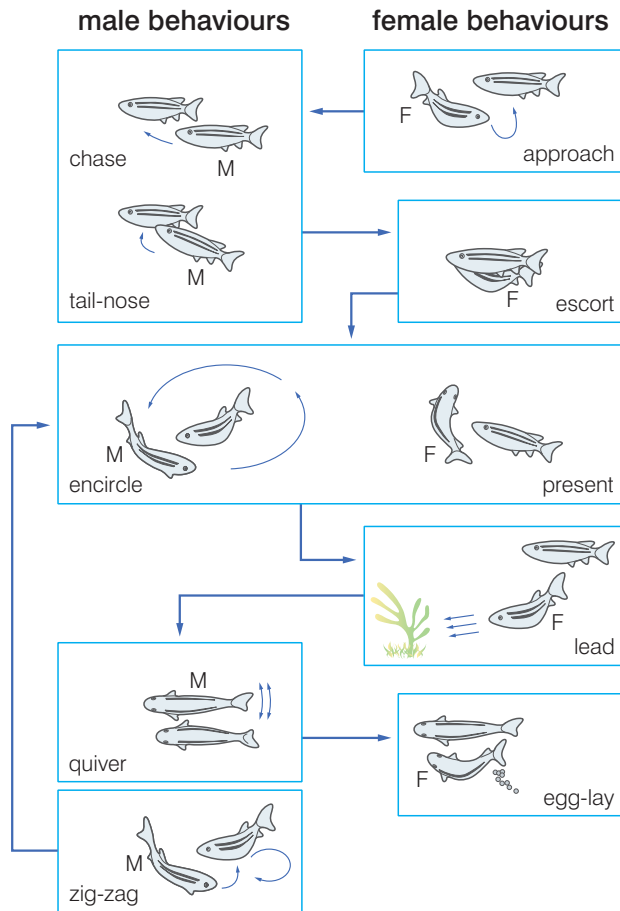
Courtship behaviour is an activity that precedes and results in mating and reproduction. It allows members of a species to recognise each other and prevents or reduces attempts at interbreeding between different species. Courtship may simply involve a few chemical, visual or auditory stimuli, or it may be a complex series of acts by two or more individuals using several methods of communication. Elaborate courtship rituals can also help to strengthen already established pair bonds. These may then last through the time it takes to rear the young and, in some cases, even longer.

There are many different methods of communication that are used to attract a mate. These include:

- the use of pheromones by some female insects to attract males from a distance
- the use of touch by painted turtles
- the courtship songs of frogs heard on spring nights in many different countries
- the song of a humpback whale under the sea, which can be heard hundreds of miles away

In most animals, courtship behaviour is innate and consists of a pre-programmed set of fixed action patterns in response to a key stimulus. Despite being innate, the fixed action patterns are often complex behaviours with the fixed action pattern in one animal (say the male) serving as the stimulus for another fixed action pattern in the other animal (the female). This interaction of fixed action patterns continues until courtship is successful or until one of the pair tires.

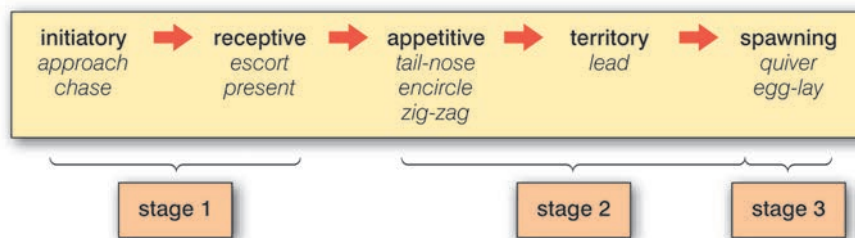
Figure 5.26 shows the sequence of fixed action patterns that make up the courtship behaviour of zebra fish. Figure 5.27 shows the role of each fixed action pattern in the overall courtship behaviour.



**DID YOU KNOW?**

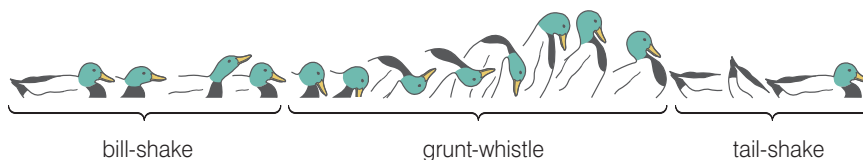
No one can state this for certain, but research with fruit flies has shown that flies with a mutant version of a single gene were much less adept at courting female mates. We don't actually share this gene with fruit flies, but we do share many others with them, so the principle may be the same in humans.

**Figure 5.26** Courtship behaviour in zebra fish



**Figure 5.27** The role of each fixed action pattern in the courtship behaviour

Fixed action patterns in courtship form an important part of the mating displays of birds also. Figure 5.28 shows the fixed action patterns of a mallard drake (male) during courtship.



**Figure 5.28** The courtship behaviour of a mallard drake

**KEY WORD**

**territory** *an area that an animal or a group of animals reserves for itself so as to exclude other members of the same species*

**Activity 5.9: The cost of defending a territory**

The territory holder usually maintains ground only by spending a lot of time and energy in its defence. Sunbirds can expend up to 3000 calories per hour patrolling and defending territory! Is it worth it?

Suggest one advantage and one disadvantage of being territorial when food supplies are:

- low
- average
- abundant



**Figure 5.29** Ethiopian wolves

**What is territorial behaviour?**

Before we describe this kind of behaviour, we must make clear what we understand by **territory**. Most animal behavioural biologists would define territory as:

*Any space that an animal defends against intruders of the same species.*

Territorial behaviour is found in nearly every species of animal, even humans. Possessing territory gives the holder areas to forage for food and so increases the chances of attracting a mate. It also reduces vulnerability to predators. Animals that do not have a territory of their own may contest with the owner for a territory that is already occupied. Such contests are called conspecific (same species) conflicts.

Territorial animals usually defend areas that contain one or more of:

- a nest
- a den, or mating site
- sufficient food for themselves and their young

Males are usually the territorial sex, but in some species (such as fiddler crabs) females maintain a territory also. When conspecific conflicts occur, they usually involve ritualistic displays and rarely involve the animals actually fighting. Residents of a territory are difficult to dislodge as they are often older and more experienced.

Defence threat displays may be visual as in the colour of feathers or fur, auditory as in birdsong or the howls of gibbons or olfactory through the deposition of scent marks. Many territorial mammals use scent marking (containing pheromones) to signal the boundaries of their territories.

The resident animal usually holds on to his (or her) territory only by expending considerable time and effort in its defence. Sunbirds, for example, can use up to 13 000 kilojoules per hour patrolling and defending their territory. This is more than the recommended daily energy intake for the average adult human male! Clearly, to expend that amount of energy, the territory must contain, at the very least, an abundance of food to support it.

The Ethiopian wolf (*Canis simensis*) is a social animal; the wolves live and hunt in packs. As a result, they maintain a group territory by marking with urine (containing pheromones). All adult animals (male and female) contribute to this marking behaviour, particularly during patrols of the territory. Some of the subadult (younger) males occasionally mark but subadult females never mark. Direct encounters between neighbouring wolves at the borders were aggressive and involved repeated chases, with the larger group more likely to win.

## Defending a territory

Some animals defend their territory by fighting with those who try to invade it. But this is the exception, rather than the rule. Fighting uses up a large amount of energy, and can result in injury or death. So, behaviour has evolved that makes fighting the 'last resort'. Marking a territory usually 'warns off' intruders. Animals that do not mark territories use threats from one, or more, of vocalisations, smells and visual displays.

The songs of birds and the loud calls of monkeys are warnings that carry for considerable distances, and warn intruders that they are approaching someone else's territory. If these warnings are ignored, and the intruder enters the territory, or two animals meet near the border of their adjacent territories, they usually threaten each other with visual displays. These displays often either:

- exaggerate an animal's size by the fluffing up of feathers or fur, or
- show off the animal's weapons.

Also, the animals may go through all the motions of fighting without ever actually touching each other, a behaviour known as **ritual fighting**.

Ritual fighting is more intense the further into an animal's territory it takes place. In this situation, the territory holder has 'nowhere to go' – he cannot retreat. If the encounter takes place nearer to the border, the ritual fighting becomes less intense and more fragmented because the territory holder has the option of retreating. This variation in the intensity of the display helps to define territorial boundaries, where the displays of neighbours are about equal in intensity, or where the tendency to attack and the tendency to retreat are about equally balanced.

Actual fighting usually only happens in overcrowded conditions where resources are scarce. Serious injury can result, and old or sick animals may die, leading to a more balanced and biologically fit population. Fighting can occur when a young male animal challenges an older one for the territory, which may be 'home' to several females as well as being a foraging area. Older animals are more experienced, but, eventually, experience will give way to the strength of a younger animal and the territory holder will be displaced. Usually, however, territoriality is an effective way of maintaining a healthy population.

### What is social behaviour?

Social behaviour is the set of interactions that occur between two or more individuals of the same species that modify the behaviour of individuals of the same species in a way that is usually beneficial to the group as a whole. It is thought to have been selected for because it has survival value to the species as a whole. Social behaviour serves many purposes and is found in a wide variety of animals, including some invertebrates, fish, birds and mammals.



*Figure 5.30 A male robin threatening an intruder by using vocalisations and by exaggerating its size*



*Figure 5.31 A younger male zebra challenges the older resident male*

#### KEY WORD

**ritual fighting** *behaviour in which the acts of fighting are displayed, without any physical contact*

Some of the benefits of social behaviour are that it allows animals to:

- form stable groups in which intra-specific aggression is reduced, sometimes as a result of hierarchies being established
- improve the effectiveness of reproduction and/or parenting through courtship behaviour (a kind of social behaviour) and pair-bond formation
- forage more efficiently – especially if sources of food are localised. Examples of this include:
  - dolphins often surround shoals of fish and take turns to swim quickly in and eat the fish trapped in the centre of the shoal
  - lions hunt in small groups when hunting large prey (such as wildebeest) but may hunt smaller prey singly
- protect themselves against attack more effectively. Examples of this include:
  - baboons co-operate to fight off a leopard, which would be extremely difficult for a single baboon
  - fish and birds moving in groups in which the movement of the whole group is co-ordinated; rapid movements one way and then another make it more difficult for a predator to attack; individuals who cannot maintain position in the group are most vulnerable
- increase the chance of surviving migration – some birds travel in large groups, for example, many geese fly in a ‘V’ formation, which reduces the total wind resistance on the birds; the lead position is rotated as this is the position that receives most wind resistance
- increase the chance of surviving extreme conditions – some birds huddle together in very cold weather, this effectively reduces the overall surface-area-to-volume ratio and can reduce heat loss by up to 50%; the birds constantly change position as the ones at the outside of the group lose heat most rapidly
- communicate across long distances



*Figure 5.32 Penguins ‘huddling’ to reduce heat loss*

### Social behaviour in bees

Honeybees and bumblebees and other species of insects exhibit what is called eusociality. Eusociality has three main features:

- there is co-operation in caring for the offspring; as a consequence, many individuals are caring for offspring that are not their own
- there are usually several generations in the colony so that it will sustain for longer and allow offspring to assist parents, and
- there is division of labour – not every individual in the group is reproductively active; in the case of bees, the queen is the only



reproductively active female with the male drones also being active; the female worker bees are more or less sterile.

Honeybees nest in large cavities such as hollowed-out trees or other enclosed spaces. They will use man-made beehives just as readily as a hollow tree trunk. Honey bees build vertical sheets of hexagonal honeycomb from wax secreted by glands in their abdomens, in which they store honey and pollen. An individual hexagon (a cell) can also be used as a home for a single developing bee larva.







There are three different types or **castes** of bees in a nest. They are:

- the queen – the only truly reproductively active female (1st caste)
- workers – non-reproductively active females (2nd caste)
- drones – reproductively active males (3rd caste)



Figure 5.33 Honeybees nesting in a tree

Table 5.3 A summary of the roles of different castes of bees

Type of adult bee	What they do	How many in a honeybee colony	How many in a bumblebee colony	What they look like in a honeybee colony	What they look like in a bumblebee colony
Queen	Lay eggs	1	1		
Worker	Take care of larvae, build and clean nest, forage	10 000–50 000	Less than 50 to over 400, depending on species		
Male	Leave nest to mate, then die	100–500	0–50, depending on species and season		

The queen secretes powerful pheromones within the nest that control the behaviour of the workers at different stages of their development and so help to maintain the social structure of the nest. She may also make aggressive attacks on maturing worker bees.

If the queen does not produce these pheromones, or if she produces too few eggs, then the structure of the nest breaks down. She may be attacked by mature workers, one of whom will replace her.

A honeybee colony may last for several years, with the male drones being driven out of the nest over winter to preserve resources for the workers and the queen. More drones will emerge the following spring.

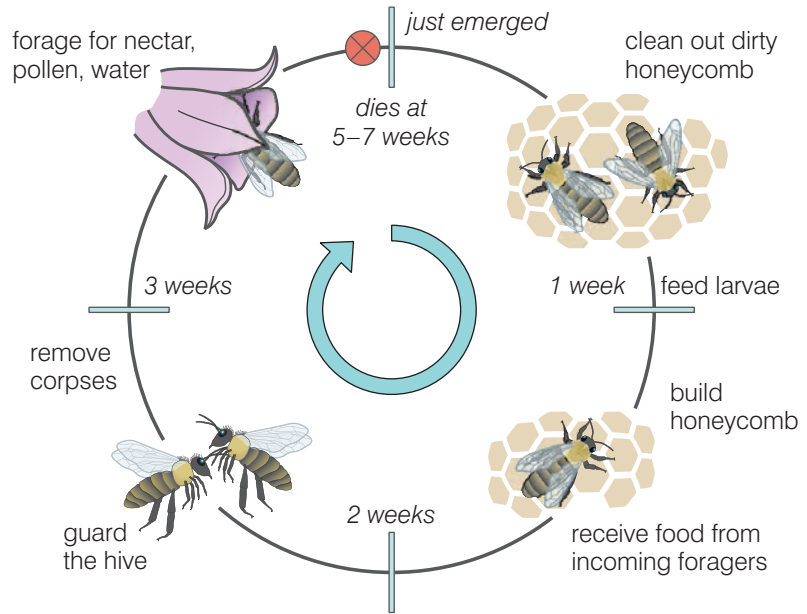
At the end of the colony cycle, the queen, the drones and most workers will die, leaving just a few large workers, who will assume the status of queens and, the following spring, fly away to establish their own colonies.

**KEY WORD**

**caste** a group within a social structure

**Activity 5.10**

Social insects show fascinating behaviour and have complex and interesting lifestyles. Work in a group to produce a classroom display on social insects. You may choose to focus on bees, which are covered in this book. Alternatively you can do some extra research and find out more about a different type of social insect, e.g. ants or termites. Make sure your display is big, clear, colourful and informative.



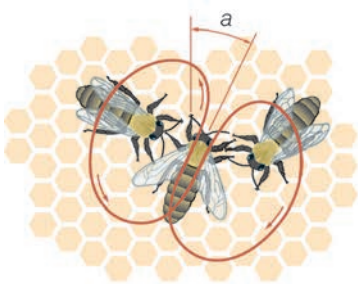
**Figure 5.34** The roles of a worker bee at different stages of development

Worker bees communicate with each other in a very special way to convey information about a source of nectar. Foragers perform a ‘wag-dance’ on the honeycomb to inform other workers of the direction of the nectar source and its distance. The dance takes the form of a ‘figure of eight’ on the vertical face of the honeycomb. Information about the nectar is conveyed in two ways:

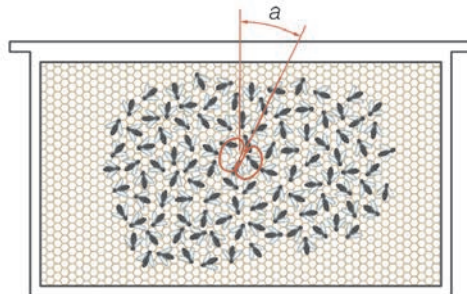
- the angle of the dance away from the vertical corresponds with the angle of the nectar from the Sun
- the length of the ‘straight-run’ part of the dance is proportional to the distance from the nest

Figures 5.35A and B show the orientation of the wag-dance on the honeycomb.

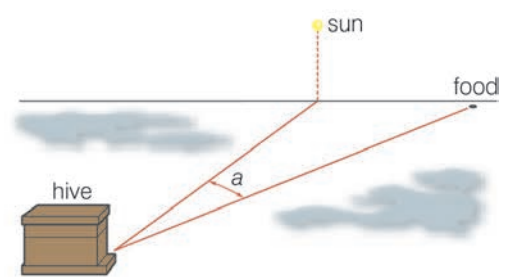
Figure 5.35C shows the relationship of this dance to the position of the Sun and the position of the nectar source.



**Figure 5.35A**

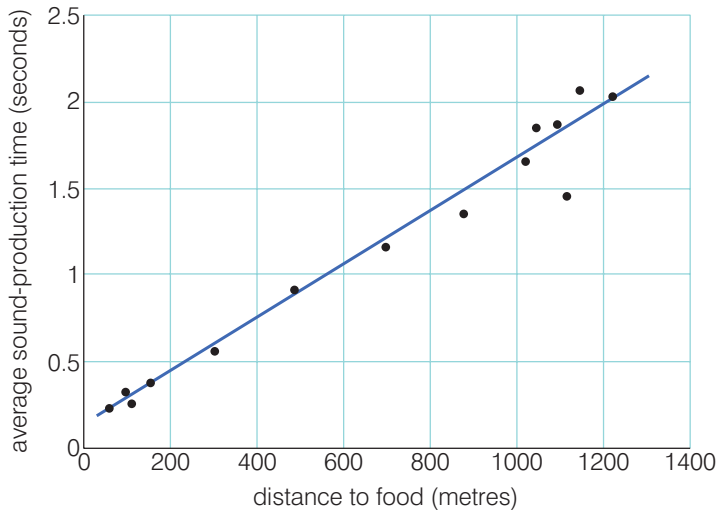


**Figure 5.35B**



**Figure 5.35C**

Recent research shows that the foraging bees also use sound to inform other bees about the distance of the source, and, perhaps, to help to ‘recruit’ these other workers. The time for which they produce their sounds is directly correlated with the distance to the nectar source, as figure 5.36 shows.



**Figure 5.36** The length of sound production by foraging workers is proportional to the distance to a food source.

The roles of the castes are the same in bumblebees and the queen maintains 'order' in the same way.

However, these nests are annual nests and a new colony establishes itself every spring.

## Review questions

Choose the correct answer from A to D.

- Which of the following statements concerning courtship behaviour is true?
  - It precedes and can result in mating behaviour.
  - It allows members of a species to recognise each other.
  - It prevents attempts at interbreeding between different species.
  - All of the above.
- Pheromones can be used to:
  - attract a mate
  - trigger alarm
  - define territories
  - all of the above
- Worker bees are:
  - sterile males
  - fertile males
  - fertile females
  - sterile females
- Communication within a honeybee nest can take the form of:
  - pheromones secreted by the queen
  - sound produced by returning foragers

- C wag-dances
  - D all of the above
5. In courtship behaviour in fish and birds, which of the following is often true?
- A A key stimulus produces a reflex response.
  - B A key stimulus produces an isolated fixed action pattern.
  - C A fixed action pattern in one animal acts as a key stimulus for a fixed action pattern in another animal.
  - D None of the above.
6. Territories are most often maintained by:
- A male animals
  - B female animals
  - C both sexes
  - D groups of animals
7. Which of the following is not true of social behaviour? Social behaviour is likely to:
- A reduce the risk of intra-specific aggression
  - B reduce the danger from predators
  - C reduce foraging efficiency
  - D reduce the risk from extreme conditions
8. Before a territorial dispute leads to actual fighting, which of the following may occur?
- A vocalisations
  - B threat displays
  - C ritual fighting
  - D all of the above
9. Which of the following is an additional 'cost' to an animal of defending a territory?
- A an increased chance of mating
  - B access to a good foraging area
  - C the expenditure of considerable time and energy
  - D decreased vulnerability to predators
10. Which of the following is not a feature of eusociality?
- A the presence of several generations in the colony
  - B co-operative foraging
  - C co-operative caring for the young
  - D division of labour

## Summary

In this unit you have learnt that:

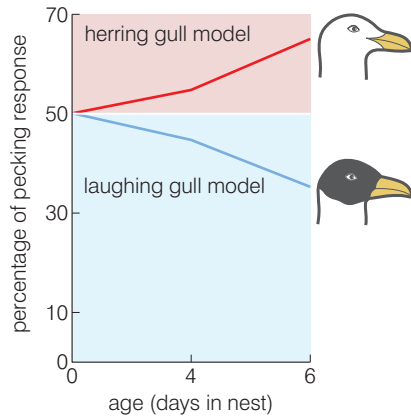
- Behaviour is the co-ordinated response of an organism to an internal or external stimulus.
- Any behaviour involves:
  - a receptor of some kind to detect the stimulus
  - an effector of some kind to produce the response
  - some kind of linking system or co-ordinating system that is influenced by the receptor and can influence the effector
- Plants show behaviour patterns that involve tropisms (growth responses to unidirectional stimuli).
- Simple animals respond to stimuli by taxes and kineses.
- Studying animal behaviour is important because we can gain information that can be used in:
  - neuroscience
  - the environment and resource management
  - animal welfare
  - science education
- Innate behaviour is any behaviour that is 'inborn' and genetically pre-programmed in some way.
- Innate behaviour includes:
  - reflex actions
  - orientational behaviour, such as taxes and kineses
  - instinctive behaviours
  - behaviours determined by biological clocks
- Reflex actions are brought about by reflex arcs comprising a sensory neurone, a relay neurone (inter-neurone) and a motor neurone.
- Somatic reflexes are usually protective, whereas autonomic reflexes control the rate of working of internal organs.
- A biological clock is an internal regulatory mechanism that controls a cyclical process in an organism; it may be:
  - circadian (controls a daily cycle)
  - lunar (controls a monthly cycle)
  - circannual (controls a yearly cycle)
- Instinctive behaviour patterns are:
  - common to all members of a species
  - fully functional the first time they are performed
  - there is a key stimulus that triggers the behaviour

- mediated by an innate releasing mechanism and a fixed action pattern
- adaptive
- Learned behaviours involve the strengthening of existing responses or the formation of new responses to existing stimuli that occur because of practice or repetition.
- Types of learned behaviour include:
  - habituation, in which a response to a stimulus becomes weaker as the stimulus is repeated more and more often
  - sensitisation, in which there is an increase in the response to a harmless stimulus when that stimulus occurs after a harmful stimulus
  - classical conditioning, in which, during the conditioning process, a naturally occurring stimulus becomes associated with a different stimulus, which now also produces the same response
  - operant conditioning, in which a behaviour is strengthened or weakened as a result of the consequences (operants) of that behaviour; reward will strengthen (reinforce) the behaviour, punishment will weaken (extinct) the behaviour
  - latent learning, in which knowledge of some kind is acquired without reinforcement and is only used later, when the need arises
  - insight learning, in which problems are solved by mental processing, rather than by trial and error
- Courtship behaviour is an activity that precedes and results in mating and reproduction and allows members of a species to recognise each other whilst preventing or reducing attempts at interbreeding between different species.
- Courtship behaviour may involve:
  - secretion of sex pheromones
  - courtship vocalisations
  - touch
  - complex displays involving a series of fixed action patterns
- Territorial behaviour is any behaviour that is used to defend an area that gives access to:
  - good foraging
  - increased mating chances
  - a den or similar
- Territorial behaviour can involve:
  - marking the area
  - threatening vocalisations

- threat displays (exaggerating size or displaying weapons)
- ritual fighting
- Social behaviour is behaviour that may allow animals to:
  - form stable groups and reduce intra-specific aggression
  - improve the effectiveness of reproduction and/or parenting
  - forage more efficiently – especially if sources of food are localised
  - protect themselves against attack more effectively
  - increase the chance of surviving migration
  - increase the chance of surviving extreme conditions
  - communicate across long distances.
- The honeybee is a social insect that has a caste system.
- The queen maintains the social structure of the colony by secreting pheromones and by aggressive attacks on maturing worker bees.

### End of unit questions

1. (a) Explain what is meant by behaviour. Illustrate your answer by reference to two examples.  
(b) Explain three reasons why we should study animal behaviour.
2. Our reflex actions can be classified into two types:
  1. somatic reflexes
  2. autonomic reflexes
 (a) Give two examples of each type.  
(b) (i) Give two similarities between the two types.  
(ii) Give two differences between the two types.
3. Herring gull chicks will peck at an orange spot on the beak of the adult bird. When they do this, the adults regurgitate food. This is an example of innate behaviour.
 (a) For this behaviour, state, with reasons:
  - (i) the key stimulus for the behaviour
  - (ii) the fixed action pattern response

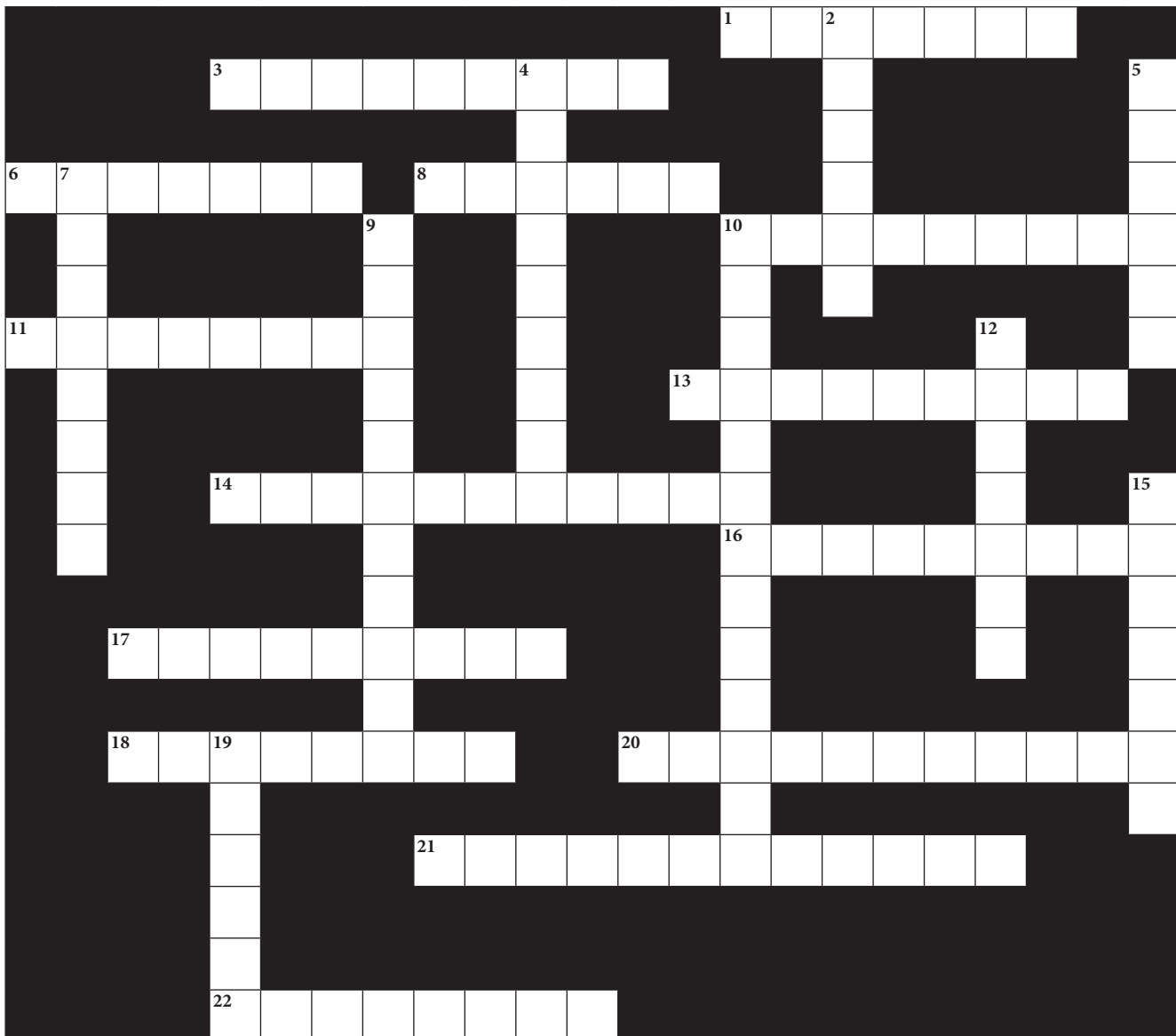


**Figure 5.37** Development of pecking responses in young herring gulls

- (b) In an investigation into this response, herring gull chicks were presented with models of adult herring gulls and adult laughing gulls after different periods of time in the nest. The chicks were fed normally throughout by their parents. The results are shown in the graph in figure 5.37.
- (i) Describe the pattern of results shown in the graph.
  - (ii) How do these results show that the behaviour is innate?
  - (iii) How do these results show that some learning is also involved?
4. What type of learned behaviour is described in each of the following examples? Give a reason for each of your answers.
    - (a) A dog is trained to herd stock animals.
    - (b) A snail is moving along a bench; an experimenter taps the bench and the snail withdraws into its shell. After several repeats of this, the snail just keeps on moving.
    - (c) After a painful blow, even relatively light pressure feels painful.
    - (d) You walk into a room where there is a loud noise and start to read a book. Initially, the noise is disturbing, but after a while you do not notice it.
    - (e) A boy watches his father changing a plug on a lamp. Some time later, he is able to carry out the same task himself without instruction.
  5.
    - (a) Describe three benefits of territorial behaviour.
    - (b) Explain how territorial behaviour can reduce intra-specific fighting.
  6.
    - (a) Explain how you could use a Skinner box to condition a rat to press a lever only when one of the lights in the box flashes.
    - (b) Explain how operant conditioning is used in shaping behaviour. Illustrate your answer by reference to two examples.
  7.
    - (a) Explain what is meant by ‘insight behaviour’. Illustrate your answer by reference to two examples.
    - (b) Explain how insight behaviour is different from:
      - (i) classical conditioning
      - (ii) operant conditioning
  8. Write a short essay on behaviour. Include the following aspects of behaviour in the essay:
    - the nature of behaviour
    - the different types of behaviour, including examples of each
    - the benefits of studying behaviour



Copy the crossword puzzle below into your exercise book (or your teacher may give you a photocopy) and solve the numbered clues to complete it.



**Across**

1. Finding solutions to a problem without trial and error is called ... learning (7)
3. The neurones that bring about a reflex action form a ... (6, 3)
6. Behaviour that develops through trial and error or insight is called ... behaviour (7)
8. Learning that takes pace without reinforcement (6)
10. Conditioning that involves associating two unrelated stimuli so that both produce the same response (9)
11. A structure that detects a change in the internal or external environment (8)
13. Patterns of behaviour that are repeated every twenty-four hours are said to have a ... rhythm (9)

14. Innate behaviour that involves a fixed action pattern response (11)
16. Behaviour to attract a mate is ... behaviour (9)
17. The co-ordinated response of an organism to a stimulus is ... (9)
18. A change in the external or internal environment that leads to a response by an organism (8)
20. Type of learned behaviour in which the response to a stimulus decreases with repeated exposure (11)
21. The response of a plant to light is ... (12)
22. The study of animal behaviour (8)

**Down**

2. Behaviour that modifies the actions of members of a group so that it is easier for the members of the group to co-exist (6)
4. This type of reflex action co-ordinates the activity of the internal organs (9)
5. Innate behaviour that produces a single response to a specific stimulus (6)
7. A structure that brings about a response (8)
9. Behaviour to defend an area of land rich in resources (11)
10. Apparatus for studying the environmental preferences of small invertebrates (13)
12. Animal behaviour in which a change in intensity of the stimulus causes a change in the rate of movement of the animal (7)
15. Conditioning that modifies behaviour through reinforcement or punishment (7)
19. Behaviour that is 'inborn' (6)

# Index

---

- abiotic conditions 55
- abiotic factors 82
- ABO blood groups 114
- Acetobacter bacterium 20
- addition point mutations 154
- adenine 129–30
- aerobic respiration 181
- Africa, biodiversity 68–9
- agriculture, biodiversity 67–8
- Agrobacterium tumefaciens 24
- AIDS 33–6, 150
- algae 4
- alleles 103–4, 106, 109–11, 113–14
- allopatric speciation 207
- Amazon rainforest 67
- amber 191
- amino acids 148
- ammonification 17, 47–8
- analogous structures 198
- anaphase (meiosis) 116–17
- animal behaviour 235–6
- antibiotic resistance
  - mutations 156
  - natural selection 187
- antibiotics 20–1
- anticodons 146
- antisense strand (DNA) 143, 144–5
- aplysia sea slug 247
- aquatic biomes 61–2
- archaeobacteria 178, 180
- Ardi 215–16
- arithmetic growth 85
- Arrhenius, Svante 175–6
- associative learning 252
- attachment formation 243
- attachment sites (tRNA) 146
- Australopithecus genus 214–16
- autonomic nervous system 239–40
- autonomic reflexes 239–40
- auxins 232–3
  
- bacilli 7
- Bacillus thuringiensis 140
- back crossing 109–10
- bacteria 3–8, 11–13
  - ecological role 16–19
  - genetic modification 23–4, 135–6
  - infectious diseases 12–13
- bacteriophages 29
- Balanus barnacle 84–5
- barnacles 84–5
- bases (DNA) 129–30
- bees 260–1
- behaviour 231–6
  - courtship behaviour 256–7
  - innate behaviour 238–43
  - learned behaviour 246–53
  - social behaviour 259–63
  - territorial behaviour 258–9
- behavioural isolation 207
- behaviourist psychologists 250
- Bernal, John Desmond 179
- biochemical theory (origin of life) 176–9
- biodiversity 63–78
- biological clocks 240–1
- biomes 58–63
- biosphere 58
- biotic factors 82–5
- bivalents (chromosomes) 115–16
- Bowlby, John 243
- brain size 216–17
- Buffon, George 183–4
  
- capsids 27
- carbon cycle 47–8
- carrying capacity 86, 87
- CD4 lymphocytes 33, 34
- centimorgans 119
- central nervous system 239–40
- central sensitisation 248
- centromeres 115
- chemo-autotrophs 181
- chimpanzees 253
- Chlamydomonas alga 4
- chromatids 115, 116–17, 128, 129–30
- chromatin 128
- chromosome mutations 157–8
- chromosomes 103–4, 115–16, 128–9, 208–9
- Chthalamus barnacle 84–5
- circadian rhythms 240–1
- circannual rhythms 240–1
- classical conditioning 248–9
- climatic climax communities 56–7
- climax communities 55–6
- clones 134, 135
- coacervates 177
- cocci 7
- codominant alleles 113–14
- codons 144, 146
- common ancestors 213–16
- comparative anatomy 197–8
- comparative biochemistry 199–201
- comparative embryology 198–9
- competitive exclusion principle 81
- complementary sequences (DNA) 132, 145
  
- conditioned responses/stimuli 248–9
- conservation (biodiversity) 76
- conspecific conflicts 258
- convergent evolution 210, 240
- coppicing 77–8
- coral reefs 73
- cosmozoan theory 175–6
- courtship behaviour 256–7
- creationism 173–4
- cross breeding 120–1
- crossing over (chromosomes) 115, 116–17
- crossover values 119–20
- cuttings (plants) 134
- cyanobacteria 180
- cytochrome 199–201
- cytokinesis 116–17
- cytosine 129–30
  
- Darwin, Charles 185–8
- day-age creationism 173–4
- decline phase (population growth) 96
- decomposers 46–7
- deficiency diseases 16
- deforestation 66–7, 70–1
- degenerate code (DNA) 143
- degenerative diseases 16
- deletion point mutations 154
- demographic transition 87–90
- denitrifying bacteria 17, 48–9
- differential stains 8
- dihybrid inheritance 112–13
- diploid cells 115
- directional selection 205
- diseases 12–16
- disruptive selection 206
- divergent evolution 209
- DNA 129–33, 142–4
- DNA helicase 132
- DNA hybridisation 199
- DNA polymerase 132
- DNA viruses 29
- Dolly the sheep 134
- dominant alleles 106, 109–11
- double helix 129–30
- double-stranded RNA (dsRNA) 149
  
- ecological niches 81
- ecological succession 54–6
- ecosystem services 74
- ecosystems 54–6
- effectors 232
- embryos 198–9
- endotoxins 8

enucleated cells 134  
 epigenetics 184  
 essential amino acids 148  
 eternity of life theory 175  
 ethics 139–40  
 Ethiopia  
   biodiversity 69–72  
   biomes 60  
   ecological succession 57  
   populations 88–90  
 Ethiopian Wildlife & Natural History Society (EWNHS) 70  
 Ethiopian wolf 258  
 ethologists 235, 247  
 eubacteria 178  
 eukaryotes 178, 180  
 eukaryotic cells 5–6, 144–5  
 eusociality 260–1  
 evolution 171–2, 191–204  
   convergent evolution 210  
   divergent evolution 209  
   evidence for evolution 191–204  
   human evolution 213–19  
   natural selection 204–8  
   polyploidy 208–9  
 exponential growth 85  
 extinction (conditioned responses) 248–9  
 extracellular digestion 46–7  
  
 F1/F2 (first/second filials) 106  
 fixed action patterns 239, 242–3, 257  
 Fleming, Alexander 140  
 food security 72–3  
 food webs 77  
 fossils 191–7  
 frameshifts (DNA) 154  
 freshwater biomes 61  
 fruit flies 119, 257  
 functional diseases 16  
 fungi 3–4, 13  
  
 gametes 115  
 gap creationism 173  
 Gause, G.F. 85  
 gene cloning 133  
 gene guns 24  
 gene pools 66, 188  
 genes 103–4, 148–50  
 genetic diseases 16, 119  
 genetic diversity 66, 69–70  
 genetic engineering 23–4, 134–7, 139–40  
 genetic fingerprinting 137–8, 140  
 genetic pedigrees 110–11  
 genetically modified organisms 134–7  
 genotypes 104, 107–8  
 geographic isolation 207  
 geographical ranges 81  
 germ theory 12  
 glofish 136  
 Gram's stain 7–8  
  
 gravitropism 233  
 grazing climax communities 56–7  
 guanine 129–30  
 gypsy moth caterpillars 82–3  
  
 habitats 81  
 habituation 247–8  
 haemoglobin 200  
 Haldane, John 177  
 haploid cells 115, 116–17  
 Harlow, Harry 235  
 hermaphrodites 123  
 herring gulls 238  
 heterozygous organisms 104, 109–11, 118  
 high activity anti-retroviral treatment 34  
 histones 103, 128  
 HIV 32–6, 150  
 hominids 214–15, 216, 219  
 hominins 214–15  
 Homo sapiens 213–14  
 homologous chromosomes 104, 115  
 homologous structures 197  
 homozygous organisms 104, 109–11  
 human evolution 213–19  
 human-induced diseases 16  
 hybrid vigour 120  
 hydroseres 56  
 hydrothermalism 181  
 hyphae 4  
  
 imprinting behaviour 188, 242, 243  
 inbreeding 120  
 indexes of diversity 64–5  
 infectious diseases 12–15  
 inheritance of acquired traits 184–7  
 innate behaviour 238–43  
 innate releasing mechanisms 242  
 insight learning 253  
 instinctive behaviour 239, 242–3  
 intelligent design 174  
 inter-specific competition 84–5  
 intra-specific competition 82–4  
 irritable bowel syndrome 16  
  
 Julius Caesar's last breath 46  
  
 key stimuli 242  
 kineses (singular kinesis) 233  
 Koch, Robert 12  
 Kohler, Wolfgang 253  
  
 lag phase (population growth) 96  
 Lamarck, Jean Baptiste 184, 187  
 latency period 34  
 latent learning 252–3  
 law of independent assortment 107, 112  
 law of segregation 106  
 learned behaviour 245–53  
 legumes 50  
  
 lichens 54–5  
 ligases 23  
 linkage (genes) 117–20  
 Lister, Joseph 12  
 loci, chromosomes 104  
 log phase (population growth) 96  
 Lorenz, Konrad 243  
 lovebirds 242–3  
 Lucy 215–16  
  
 macrophages 33  
 mangroves 73  
 marine biomes 61  
 meiosis 115–17  
 membranes 5–6  
 Mendel, Gregor 104–8, 188  
 messenger RNA (mRNA) 142, 144–7  
 metaphase (meiosis) 116–17  
 microorganisms 3–4  
   *see also* bacteria  
   industrial uses 19–22  
   infectious diseases 12–15  
 micropropagation 134  
 Miller, Stanley 177  
 mini satellites 137  
 mis sense coding 154  
 monohybrid crosses 104–9  
 morality 139–40  
 Morgan, Thomas 119  
 mortality 90  
 motile organisms 4  
 multifactorial diseases 16  
 multiple allele inheritance 113–14  
 mutations 152–8, 200  
 myalgic encephalopathy (ME) 16  
 mycelium 4  
 mycorrhizae 77  
  
 natality 90  
 natural selection 204–8  
 nitrifying bacteria 17, 48–9  
 nitrogen cycle 17–18, 48–50  
 nitrogen-fixing bacteria 17, 48–50  
 non coding DNA 137  
 non overlapping code (DNA) 143  
 nucleotides 128, 129–30  
 nutrients 45–7  
  
 Old Earth creationism 173  
 Oparin, Aleksandr 177  
 operant conditioning 250–2  
 orientation behaviour 238–9  
 oxygen 181  
  
 panspermia theory 175–6  
 Paramecium organism 85  
 parasympathetic reflexes 239–40  
 Pasteur, Louis 12, 175  
 pathogens 12  
 Pavlov, Ivan 249  
 penicillin 140  
 pentadactyl limbs 198

peptidoglycan 8  
 peripheral nervous system 239–40  
 peripheral sensitisation 248  
 phenotypes 104, 109–11, 113–14  
 pheromones 256  
 phosphorus cycle 50  
 photo-autotrophs 180–1  
 photosynthesis 180–1  
 phototropism 232–3  
 phylogenetic trees 200–1  
 pickling 20  
 pineal gland 240–1  
 pioneer species 54  
 plankton 4  
 plasmids 23–4, 135, 156  
 point mutations 154  
 polymerase  
   *see also* RNA polymerase  
 polymerase chain reactions (PCRs)  
   133, 137  
 polynucleotide strands 129–30  
 polyploidy 208–9  
 populations 80–91  
   humans 86–91  
 potassium-argon dating 194–6  
 predation 82  
 primary succession 57  
 progressive creationism 174  
 prokaryotes 178  
 prokaryotic cells 5–6, 147–8  
 prophase (meiosis) 116–17  
 proteins 147–8  
 proto-oncogenes 155  
 protoctista 5  
 protozoa 3, 13  
 Punnett squares 107, 112  
  
 radiocarbon dating 194–6  
 rats 252–3  
 receptors 232  
 recessive alleles 106, 113–14  
 recombinant types 119  
 recycling (nutrients) 45–7  
 Redi, Francisco 174  
 redox reactions 48–9  
 reflex actions 239–40  
 reservoirs of infection 14  
 restriction endonucleases 23  
 retroviruses 29  
 rhesus monkeys 235  
 ribosomes 142, 146  
 Richter, Hermann 175–6  
  
 ritual fighting 259  
 RNA 129–30  
 RNA polymerase 145, 148–9  
 RNA viruses 29  
  
 saprobionts 4  
 saprobiotic nutrition 46–7  
 seasonal isolation 207  
 secondary succession 57  
 selective breeding 119, 201  
 sense strand (DNA) 143  
 sensitisation 248  
 sensory habituation 247  
 seres (ecological succession) 54–6  
 sewage treatment 21–2  
 sex determination 121–5  
 sex-influenced traits 124  
 sex-limited traits 124  
 sex-linked traits 124  
 short interfering RNA (siRNA) 149–50  
 sickle cell anaemia 153  
 Simpson's index of diversity 64–5  
 Skinner, B.F. 250–1  
 Skinner boxes 251  
 social behaviour 259–63  
 social diseases 16  
 somatic nervous system 239–40  
 somatic reflexes 239–40  
 special creationism 173–4  
 speciation 204, 206–8  
 species 204  
 species diversity 64–6, 74  
 species richness 64–70  
 spirochaetes 7  
 spontaneous generation 174–5  
 SRY gene 124  
 stabilising selection 205–6  
 Staphylococcus aureus 156  
 stationary phase (population growth)  
   96  
 steady state theory 176  
 sticklebacks 242  
 sticky ends (DNA) 23, 160  
 stimuli 232–3  
 strata (rocks) 193, 194  
 Sturtevant, A.H. 119  
 substitution point mutations 152–3  
 succession (ecosystems) 54–6  
 Suess, Eduard 58  
 sugar-phosphate backbone 129–30  
 sulphobacteria 180  
 sulphur cycle 18–19, 51  
  
 supra-chiasmatic nucleus 241  
 Sutherland, John 179  
 sympathetic reflexes 239–40  
 sympatric speciation 207–8  
  
 T-helper cells 33  
 taxes (singular taxis) 233  
 telophase (meiosis) 116–17  
 temporal isolation 207  
 terrestrial biomes 59–60  
 territorial behaviour 258–9  
 tetraploid cells 208–9  
 theistic evolution 174  
 thymine 129–30  
 Tolman, Edward 252–3  
 traits 106  
 transamination 148  
 transcription (DNA) 142, 145  
 transcription factors 148–9  
 transfer RNA (tRNA) 142, 146  
 translation (RNA) 142  
 transmission  
   infectious diseases 14–15  
   viruses 31  
 triplets (DNA bases) 142–4  
 tropical rainforests 65–7  
 tumour suppressor genes 155  
  
 unconditioned responses/stimuli  
   248–9  
  
 vectors (genes) 23  
 vinegar 20  
 virions 27  
 viruses 4, 13, 26–31  
  
 water cycle 52  
 weak panspermia theory 176  
 woodland climax communities 55–6  
 woodlice 233–5  
  
 X chromosome 121–5  
 xeroseres 56  
  
 Y chromosome 121–5  
 yeasts 3  
 Young Earth creationism 173  
  
 zebra fish 136, 256–7





